

TRAFFIC SIGNAL MANAGEMENT OF EMERGENCY VEHICLE AND HEALTH MONITORING OF IN PATIENT

S. Sasikala¹, A. Mohamed Nazeer²

^{1,2} Lecturer, Electrical and Electronics Engineering, PSG Polytechnic College, Coimbatore

Abstract - Existing emergency vehicle systems does not communicate the condition of the patient travelling to the hospital before arrival. So the proposed system automates to communicate the condition of the patient to the hospital while travelling. This paper focuses the prototype design of health care monitoring unit and intelligent traffic control unit while the victim is travelling. The designed health care monitoring unit measures health parameters such as heart rate, body temperature, blood group, blood level. The health parameter details of the patient are transmitted to the hospital's web server using Wi-Fi module. The hospital gets ready to provide treatment to the victim coming to the hospital. The intelligent traffic control unit has Arduino, GPS module to detect the location, traffic light module to control the traffic lights. The location details are sent to the traffic control room using Wi-Fi module. When an emergency vehicle arrives near a traffic signal, GPS tracker kept in traffic control room detects it and makes green signal it passes. It makes all other sides of the signal red. The travelling time is reduced and the patient gets immediate treatment when the patient reaches the hospital. This system can be used in real traffic world to control the movement of emergency vehicles, VIP vehicles, fire engines etc easily.

Key Words: ARDUINO, traffic signal management, health monitoring, GPS.

1. INTRODUCTION

Emergency occurs anywhere, at any time and in various ways make one at risk. So it is crucial and important to establish direct, fast and efficient technique to reach hospitals without delay. With the increased number of population the poor traffic congestion has grown to an alarming event. This problem has to be properly addressed and the appropriate measures have to be taken. Even if each and every vehicle passing through the traffic has its own need, the prior importance is given to the emergency vehicles which needs to wait longer time on the traffic thereby increasing the probability of the risk. Transportation of a patient during emergency condition is difficult during peak hours. The time after an accident is actually the precious hours as a measure of an emergency response system. The first prevailing technology was to control all the traffic signals from a common control. But this technology was not that much successful due to many communication issues. The location of the emergency vehicle cannot be monitored by the control room. All the information cannot be communicated that much easily.

2. EXISTING SYSTEM

The existing technology uses RF transmitter mounted on a top of the emergency vehicle and RF receivers are placed in every road leading to the signal at a suitable distance from the traffic signal. Initially the driver of the emergency vehicle switches on the transmitter through a switch placed on the steering wheel. This makes the receiver output to go high and thereby interrupting the Microcontroller. At the beginning of the interrupt sub routine, all the port pins are scanned to determine in which lane the emergency vehicle is approaching and the corresponding lane is made green. Existing emergency vehicle systems does not communicate the condition of the patient travelling in the emergency vehicle to the hospital before itself. So the proposed system automates to communicate the condition of the patient in the emergency vehicle to the hospital while travelling itself. This paper discusses the wireless technology and high speed microcontroller to provide fast and clear flow of traffic for the emergency vehicle to reach the destination on time.

3. PROPOSED EMERGENCY VEHICLE SYSTEM

This developed system includes health care monitoring unit and intelligent traffic control unit for the victim travelling in the emergency vehicle. The health care monitoring unit has Arduino Microcontroller, GPS module to show the shortest route to hospital using LCD display, heart rate sensor to measure the heart rate, the temperature sensor for body temperature measurement. The health details of the patient are transmitted to the hospital's web server using Wi-Fi module. The intelligent traffic control unit has Arduino which is a high speed Microcontroller, GPS module to detect the location, location details are sent to the traffic control room using Wi-Fi module and traffic light module to control the traffic lights.

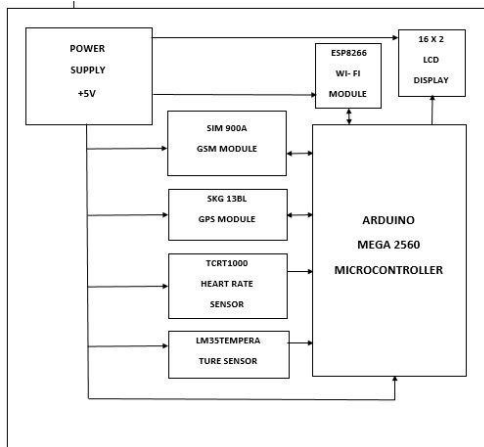

Fig. 1 Block Diagram of Emergency vehicle Unit

The fig.1 shows the block diagram of the emergency vehicle unit of emergency vehicle system. Smart traffic system consists of two units namely the vehicle unit and the traffic signal unit.

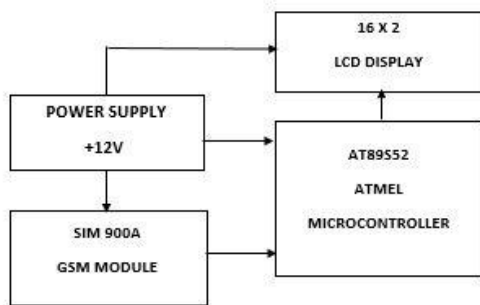

Fig. 2 Traffic Signal Unit Block Diagram

The vehicle unit consists of GSM and GPS module, Arduino MEGA microcontroller and LCD display. The vehicle unit detects the location of the emergency vehicle with the help of the GPS module and sends it to traffic control unit. In the proposed system there is a traffic control unit which controls the traffic once the message is received from the emergency vehicle unit.

The fig.3 shows the circuit diagram of emergency vehicle unit. In the traffic light circuit the SMS from the emergency vehicle unit is received by the GSM module. Once when the SMS is received the signal changes to green. Once the GSM module receives SMS, the values of the SMS is given to the microcontroller and the microcontroller displays GREEN signal.

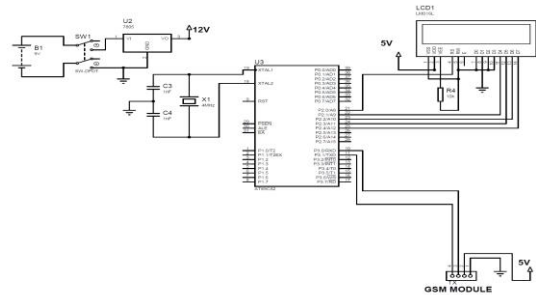

Fig.3 Circuit Diagram of Emergency Vehicle Unit

The fig.4 shows the circuit diagram of traffic signal unit. Components used for traffic signal unit are AT8952, GSM Module SIM900A, 16 x 2 LCD display.

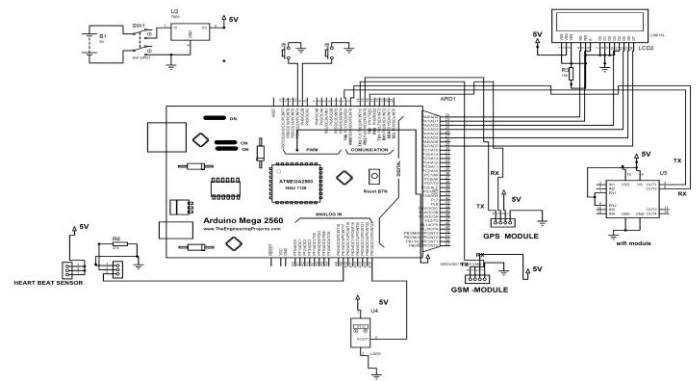

Fig.4 Circuit Diagram of Traffic Signal Unit

Fig.5 and Fig 6 shows the experimental hardware setup of Emergency Vehicle Unit Signal Circuit and Traffic Signal Circuit.

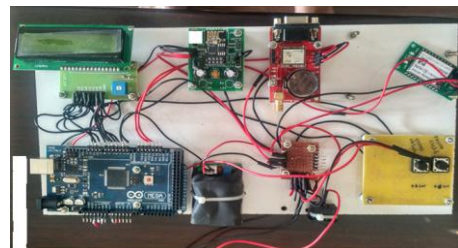

Fig. 5 Emergency Vehicle Unit Signal Circuit

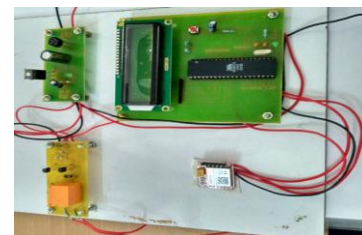

Fig. 6 Traffic Signal Circuit

4. SIMULATION RESULTS AND FINDINGS OF HARDWARE OUTPUT

The results of experimental hardware are given for emergency vehicle unit. The temperature sensor values and heart beat sensor values are tabulated in table 1 and table 2.

Table 1 -Temperature Sensor Values

S.No.	Temperature in Farenheit	Voltage in mV
1	86	310
2	90	331
3	92	343
4	93.5	350

Table 2- Heart beat Sensor Values

S.No	Name of the Person	Heart Beat	Voltage in V
1	A	0	4.3
2	B	72	1.6
3	C	85	1.4
4	D	96	1.2

Hardware output display of temperature and heartbeat is shown in fig. 7.



Fig.7 Heart Beat and Temperature Value

The simulation results of heartbeat and temperature is shown in fig.8, fig 9 and fig 10.

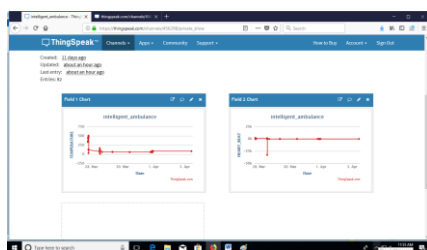

Fig. 8 Graph chart for temperature and heart rate sensor

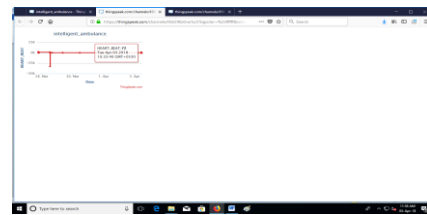

Fig.9 Heartbeat Chart

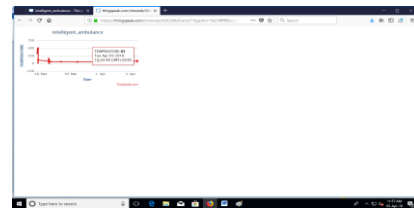

Fig.10 Temperature Chart

The detected Location based on latitude and longitude number of the emergency vehicle is sent as a SMS and interfaced with map. The simulated solution is nearly matching with experimental set up.

5. CONCLUSION

With automatic traffic signal control based on the traffic density in the route, the manual effort on the part of the traffic policeman is saved. As the entire system is automated, it requires very less human intervention. Emergency vehicles like ambulance, fire service trucks need to reach the destination at the earliest. If the vehicle spends lot of time in traffic jams, precious lives of many people may be in danger. Clearance of the traffic signal turns to green once the emergency vehicle passes by this new proposed system. The signal turns to red when the policeman in the traffic junction touches the restart button. This can be extended to large number of signals using IoT and a separate unit can be developed at every point of the traffic signal junction so that the policemen at the junction can monitor the movement of the emergency vehicle. The location details sent as SMS can be uploaded to cloud so that the movement of the emergency vehicle can be monitored in real time. More number of health parameters can be added and independent server connecting all the hospitals can be developed.

REFERENCES

[1] Ahmed S Salama, Bahaa K Saleh and Mohamad m Eassa, 2010,"Intelligent Cross Road Traffic Management System", IEEE, November 2010.
 [2] Yi-Li Haung,Shih-Han Chen, Fang-Yieleu, Chia Yin Ko and Jung-Chun Liu,"A Secure Traffic Control System with emergency Handling For Emergency vehicles",IEEE, 2014.
 [3]Maram Bani Younes, Azzedine Boukerche and Abdelhamid Mammeri, "Context-Aware Traffic Light Self

Scheduling Algorithm For Intelligent Transportation System”, IEEE 2016(WCNC 2016).

[4]Rjeshwari.S, SanthoshsHebbar, VaraprasadGolla, “Implementing Intelligent Traffic Control System for Congestion Control, Emergency vehicle Clearance and Stole Vehicle Detection”, IEEE – 2013.

[5] HamzaBaali, HamzaDjelouat, Abbes Amira, and FaycalBensaali, “Empowering Technology Enabled Care Using IoT and Smart Devices: A Review”,IEEE sensors journal, Vol. 18, No. 5, March 1, 2018.

[6] Ruhani Ab. Rahman, NurShima Abdul Aziz, MurizahKassim, Mat IkramYusof, “ IoT-based Personal Health Care Monitoring Device for Diabetic Patients,IEEE 2017.

[7] P. Priyanka, V. Sharmila , V.C. Sindhu, P. Sangeetha, “Intelligent Traffic Control System for Emergency vehicle Clearance and Stolen Vehicle Detection”, IRJE 2015,

[8] Michael Margolis “Arduino Cookbook”, by O’Reilly Media, Inc,2011 (pg.no:100 - 130).

[9] Malik Schmidt “Arduino: Quick-Start Guide”, by Pragmatic Bookshelf,2011 (pg.no:89).

[10] Mc Roberts “Beginning Arduino”, by Technology in Action,2010 (pg.no:129 - 171).

[11]Janice GillispieMazidi and Muhammed Ali Mazidi, “8051 Microcontroller and Embedded Systems”, Pearson Education Publishing,2010.(pg.no:96)