

# Study on different Technology Used in Solar Dryer: A review

Nitesh Ambadas Pachpor<sup>1</sup>, Priti Prakash Lad<sup>2</sup>

<sup>1</sup>Asst.Professor, Farm power and Machinery,College of Agricultural Engineering and Technology,Saralgaon,Thane,Maharashtra,India.

<sup>2</sup>Asst.Professor,Agriculture Process Engineering, College of Agricultural Engineering and Technology,Saralgaon,Thane,Maharashtra,India.

\*\*\*

**Abstract** - Solar is one of the renewable and sustainable sources of power that attracted a large community of researchers from all over the world. This is largely due to its abundant in both direct and indirect form. As such the development of efficient and inexpensive equipment for the drying of agricultural and marine products using solar power evolved thereby improving the quality of the products as well as improving the quality of life. The use of solar dryers in the drying of agricultural products can significantly reduce or eliminate product wastage, food poisoning and at the sometime enhance productivity of the farmers towards better revenue derived. Drying is helpful in preserving food product for long time; it prevent product from contamination. Direct solar drying, indirect solar drying, and mixed mode solar drying these are different solar drying methods. Primarily open to the sun or direct sun drying technique is used

**Key Words:** (Size 10 & Bold) Key word1, Key word2, Key word3, etc (Minimum 5 to 8 key words)...

## 1. INTRODUCTION

Drying is a complicated process involving simultaneous heat and mass transfer. The required amount of energy to dry a particular product depends on many factors, such as initial moisture content, final moisture content, drying air temperature, relative humidity and velocity. Various mathematical models describing the drying behavior of different food materials have been proposed to optimize the drying process and design efficient dryers. Open air and uncontrolled sun drying is still the most common method used to preserve and process Agricultural product. But uncontrolled drying suffers from serious problem of wind born dust, infestation by insect, product may be seriously degraded to the extent that sometimes become market valueless and resultant loss of and have to the food quality may have adverse economic effects on domestic and international market. Dryers have been developed and used to dry agricultural products in order to improve shelf life. Because of full scale experimentation of different products and configurations of drying system is very time consuming and costly. In order to improve the quality, the traditional natural sun drying must be replaced by modern drying methods. Drying characteristics of specific products should be determined to improve the quality.

## 1.1 Classification of Solar Dryer

Solar dryers are available in a range of size and design and are used for drying of various agricultural products. Various types of Dryers are available in the market as per requirement of farmers. Primarily all the drying systems are classified on the basis of their operating temperature ranges that is High Temperature solar dryer and Low Temperature Solar dryer. Following criteria's are required for the classification of solar dryer:-

- a) Air movement mode
- b) Insulation exposure
- c) Air flow direction
- d) Dryer arrangement
- e) Solar contribution
- f) Type of fruit to be dried

### 1) Direct Solar Dryer

It is a type of dryer in which solar radiation is directly absorbed by the product to be dried. It is also called as natural convection cabinet dryer since the solar radiation is directly fall on the product, the quality of product is reduced. This dryer comprises of a drying chamber that is covered by a transparent cover made of glass or plastic. The drying chamber is usually a shallow, insulated box with air-holes in it to allow air to enter and exit.



Fig -1: Direct solar dryer

## 2) Indirect Solar Dryer

The solar radiation gained by the system is utilized to heat the air which flows through the product to be dried in this dryer. In this of dryer quality of product improved though drying rate increased. Heated air is blown through the drying chamber. At the top of drying chamber vents are provide through which moisture is removed. In indirect type of solar drying systems a better control over drying is achieved. Fig. describes another principle of indirect solar drying which is generally known as conventional dryer.

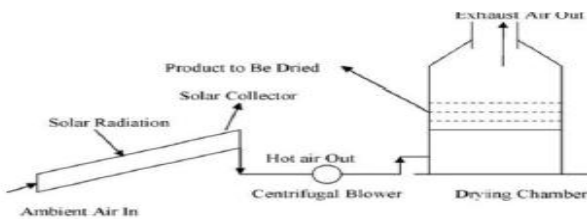

Fig. 5: Line Diagram of Indirect Solar Dryer.



Fig -2 : Indirect Solar air Heater

**3) Mix mode solar dryer:** Mix mode solar dryer is the combination of direct and indirect type of solar dryer. Product is dry by directly exposure to the sun light and also by hot air supplier on it. Air is heated in a collector and then this hot air is supplied to the drying chamber and drying chamber top is made up of glass cover. Which can directly absorbs solar radiation. In this way drying rate is higher as compared to direct solar drying. Figure 3 shows schematic views of mixed mode natural convection solar crop dryer (MNCSCD).

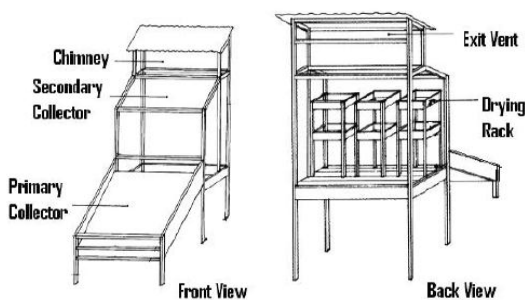

Fig-3: Mixed Mode Solar Dryer

## 2. Literature Review

[1] Diemuodeke E. OGHENERUONA\*, Momoh O.L. YUSUF:- Designed and fabricated direct natural convection solar dryer to dry tapioca in rural areas. A minimum of 7.56 m<sup>2</sup> solar collector area is required to dry a batch of 100 kg *tapioca* in 20 hours (two days drying period). The initial and final moisture content considered were 79 % and 10 % wet basis, respectively. The average ambient conditions are 32°C air temperatures and 74 % relative humidity with daily global solar radiation incident on horizontal surface of 13 MJ/m<sup>2</sup>/day. The weather conditions considered are of Warri (lat. 5°30', long. 5°41'), Nigeria. A prototype of dryer was fabricated with minimum collector area of 1.08 m<sup>2</sup>

[2] Ahmed AbedGatea A cylindrical section solar drying system was designed and analysis of performance takes place. The system consists of a solar collector flat plate with length of 1.10 m and width of 1.10 m drying chamber cylindrical section and a fan was built and designed for the purpose of drying 70 kg of bean crop. The performance of the solar air collector using three air flow rates has been tested. The highest temperature (71.4°C) of the outlet solar collector has been obtained at 11 am. At radiation intensity 750 W/m<sup>2</sup> for air flowrate of 0.0401 kg/s was obtained and minimum temperature (40.0°C) was obtained when air flow rate was 0.0675 kg/s at radiation intensity 460 W/m<sup>2</sup> was obtained. The maximum value of average thermal efficiency 25.64% of the solar air collector obtained at air flow rate of 0.0675 kg/s, and minimum average thermal efficiency is 18.63% at air flow rate of 0.0405 kg/s. The initial moisture content of beans was 70% and final 14% when the air flow rate was 0.0405 kg/s 18% d.b at air flow rate of 0.0540 kg/s and 20% d.b at air flow rate of 0.0765 kg/s.

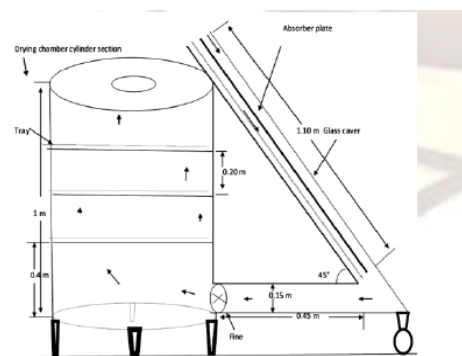

Fig-4: sectional view of the solar drying system a cylindrical section

[3] J. Banout et.al Doubled Pass Solar Dryer (DPSD) was designed for drying red chilli in central Vietnam and DPSD is compared with cabinet dryer (CD) and traditional open sun drying. They found that average drying temperatures were 60°C, 52°C and 35.8°C and corresponding relative humidity 34%, 45% and 62% for DPSD, CD and open air sun drying, respectively. The overall drying efficiency of DPSD is 20% which is typical for forced convection solar dryer. The

moisture content of fresh red chilli was almost similar during all drying tests where as the initial values were 9.18kg/kg,9.17kg/kg and 9.30kg/kg (db) for DPSD, CD and open-air sun drying, respectively. Where the final moisture content in case of DPSD 0.05kg/kg was reached after 23 h, 0.09kg/kg after 29h for CD and 0.18kg/kg after 36 h in case of open sun drying (excluding nights).The performances of a new designed DPSD have been compared with those of a typical CD and a traditional open-air sun drying for drying of red chilli. The DPSD resulted in the shortest drying time to meet desired moisture content of chilli (10% w.b.), which corresponds to the highest drying rate comparing to other methods. Although the construction cost of DPSD was higher than CD the overall drying efficiency was more than two times higher in case of DPSD compared to CD. Hence, Double pass solar drier was found to be technically and economically suitable for drying of red chillies under the specific conditions in central Vietnam.

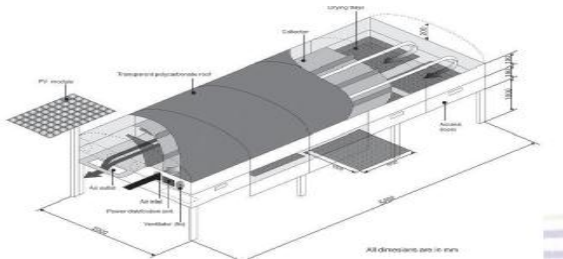

Fig- 5: Double pass solar dryer

[4]M.A. Hossaina and B.K. Bala Designed and developed A Mixed mode type forced convection solar tunnel drier to dry hot red and green chillies under the tropical weather conditions of Bangladesh as shown in figure .The dryer consists of (1.air inlet 2.fan;3.solar module;4.solar collector;5.side metal frame;6.outlet of the Collector7.wooden support; 8.plastic net; 9.roof structure for supporting the plastic cover; 10.base structure for supporting The dryer;11.rolling bar; 12,outlet of the drying tunnel.)Moisture content of red chilli was reduced from 2.85to 0.05 kg/kg(db) in 20 h in solar tunnel drier and it took 32 h to reduce the moisture content to 0.09 and 0.40 kg/kg (db) in improved and conventional sun drying methods, respectively.

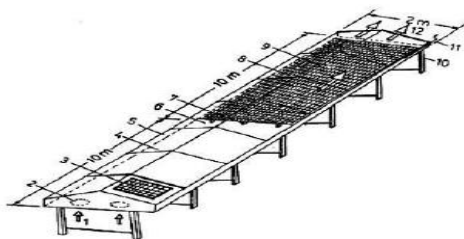

Fig -6 : Schematic views of the MNCSCD

[5] F.K. Forson.et.al Designed A mixed-mode natural convection solar crop dryer (MNCSCD) for drying cassava and other crops. A batch of cassava 160 kg by mass, having

an initial moisture content of 67% wet basis from which 100 kg of water is required to be removed to have it dried to a desired moisture content of 17% wet basis, is used as the drying load in designing the dryer. A drying time of 30–36 h is assumed for the anticipated test location (Kumasi; 6.71N,1.61W) with an expected average solar irradiance of 400W/m<sup>2</sup> and ambient conditions of 25 1C and 77.8% relative humidity. They concluded that A minimum of 42.4m<sup>2</sup> of solar collection area, according to the design, is required for an expected drying efficiency of 12.5%. Under average ambient conditions of 28.2 1C and 72.1% relative humidity with solar irradiance of 340.4W/m<sup>2</sup>, a drying time of 35.5 h was realized and the drying efficiency was evaluated as 12.3% when tested under full designed load signifying that the design procedure proposed is sufficiently.

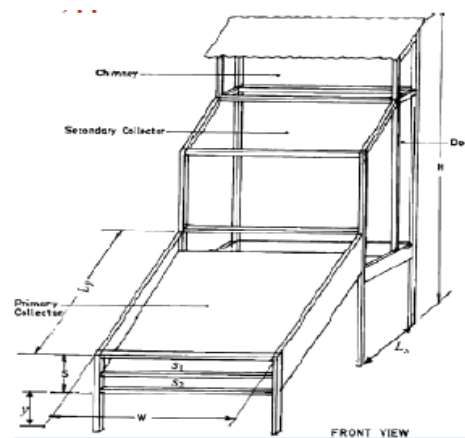

Fig-7: Schematic views of the MNCSCD

6] EL- Amin Omda Mohamed Akoy.et.al A natural convection solar dryer(Cabinet Type) was designed and constructed to dry mango slices. They concluded that the designed dryer with a collector area of 16.8m<sup>2</sup> is expected to dry 195.2kg fresh mango (100kg of sliced mango) from 81.4% to 10% wet basis in two days under ambient conditions during harvesting period from April to June. A prototype of the dryer is designed and constructed that has a maximum collector area of 1.03m<sup>2</sup>.

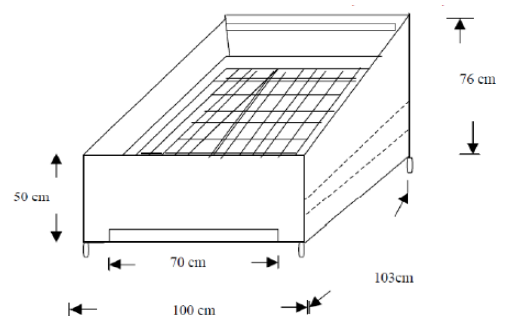

Fig -8 : Isometric View Of Solar Dryer



[7] Ahmed AbedGatea Designed and developed solar drying system for maize with V-groove collector of 2.04 m<sup>2</sup> area, drying chamber and blower. The thermal energy and heat losses from solar collector were calculated for each three tilt angles (30°, 45°, 60°). The results obtained during the test period denoted that the maximum gained energy occurred at 11 o'clock hour and then gradually declined since the maximum solar radiation occurred at this time. Other many important results found are The theoretical thermal energy, the experimentally actual heats gain increase by increasing radiation intensity, the maximum values occurred at the 11 am and then gradually declined. The energy gained obtained at the angle tilt 45° is higher than the corresponding values obtained at 60°, 30° tilt.

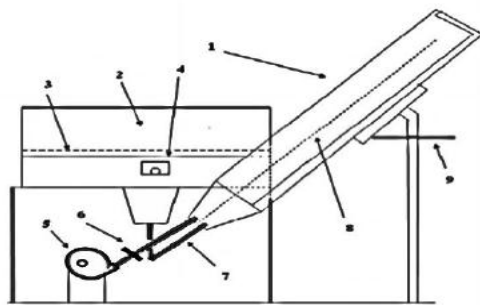

Figure 2. Section of the solar drying system: 1. Solar collector. 2. Drying chamber. 3. Drying tray. 4. Thermostat temperature. 5. Air blower. 6. Air valve. 7. Connecting pipes. 8. Absorption plates of two air passes. 9. Slide rule.

Fig -9 : Section Of Solar Dryer

[8] Bukola O. Bolaji.et.al:- Designed, constructed and tested the solar wind-ventilated cabinet dryer in Nigeria on latitude 7.5o N.Comparatively, drying with the solar cabinet dryer showed better results than open air-drying. During the period of test, the average air velocity through the solar dryer was 1.62 m/s and the average daylight efficiency of the system was 46.7%. The maximum drying air temperatures was found to be 64oC inside the dryer. The average drying air temperature in the drying cabinet was higher than the ambient temperature in the range of 5oC in the early hours of the day to 31oC at mid-day.80% and 55% weight losses were obtained in the drying of pepper and yam chips, respectively, in the dryer .

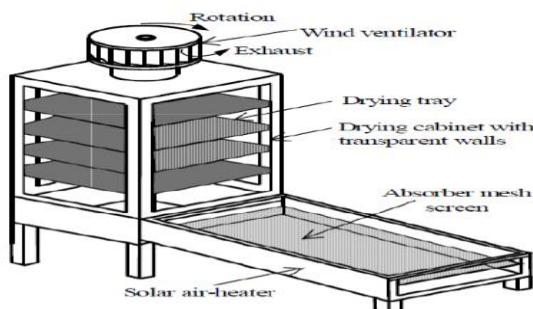

Fig- 11 : Solar Cabinet Dryer

[9] Bukola O. Bolaji and Ayoola P. Olalusi: Built a simple and inexpensive mixed mode solar dry locally source materials. The temperature rise inside the drying cabinet was up to 24o C (74%) for a hours immediately after 12.00h(noon). The drying rate, collector efficiency and percentage of moist removed (dry basis) for drying yam chips were 0.62 kgh-1, 57.5 and 85.4% respectively. The dryer sufficient ability to dry food items reasonably rapidly to a safe moisture level and simultaneously it superior quality of the dried product.

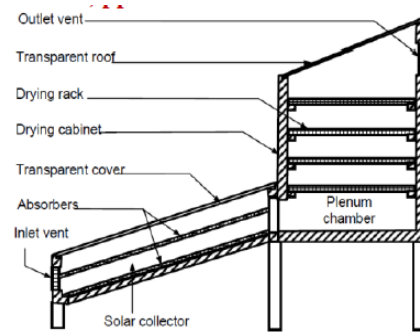

Fig-13: Mixed Mode Dryer

[10] M. MOHANRAJ, P. CHANDRASEKAR:-The performance of an indirect forced convection solar drier integrated with heat storage material was designed, fabricated and investigated for chili drying. The drier with heat storage material enables to maintain consistent air temperature inside the drier. The inclusion of heat storage material also increases the drying time by about 4 h per day. The chili was dried from initial moisture content 72.8% to the final moisture content about 9.2% and 9.7% (wet basis) in the bottom and top trays respectively. They concluded that, forced convection solar drier is more suitable for producing high quality dried chilli for small holders. Thermal efficiency of the solar drier was estimated to be about 21% with specific moisture extraction rate of about 0.87 kg/kWh.

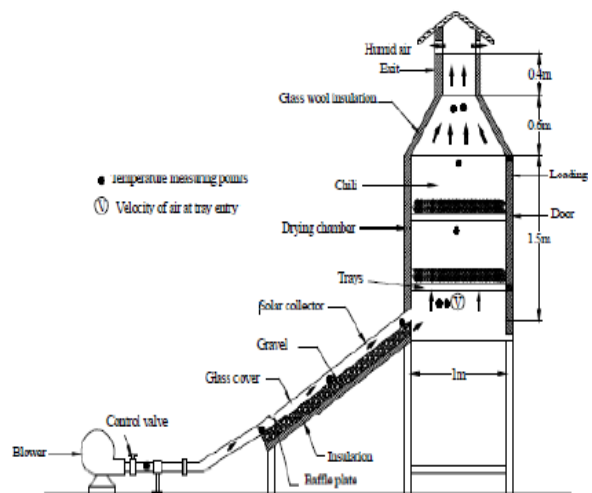

Fig-15: Schematic View Of Experiment setup

### 3. CONCLUSIONS

Solar dryer is the best alternative option to avoid disadvantages of conventional drying methods. Solar dryer is designed particularly for drying agricultural products. Solar dryers do have short comings. They are of little use during cloudy weather. During fair weather they can work too well. Although solar dryers involve an initial expense, they produce better looking, better tasting, and more nutritious foods, enhancing both their food value and their marketability. They also are faster, safer, and more efficient than traditional sun drying techniques.

### REFERENCES

- [1] Diemuodeke E. OGHENERUONA, Momoh O.L. YUSUF. Design and Fabrication of a Direct Natural Convection Solar Dryer for Tapioca; Department of Mechanical Engineering, University of Port Harcourt Department of Civil and Environmental Engineering, University of Port Harcourt, P.M.B. 5323, Choba, Rivers State, Nigeria; Leonardo Electronic Journal of Practices and Technologies ISSN 1583- 1078; Issue 18, January-June 2011 p. 95- 104.
- [2] Ahmed AbedGatea. Design and construction of a solar drying system, a cylindrical section and analysis of the performance of the thermal drying system. Department of Agricultural Mechanization, College of Agriculture, University of Baghdad, Iraq, July 2010
- [3] J. Banout, P. Ehl, J. Havlik, B. Lojka, Z. Polesny, V. Verner. Design and performance evaluation of a Double-pass solar drier for drying of red chilli, Dec 2010.
- [4] M.A. Hossaina and B.K. Bala. Drying of hot chilli using solar tunnel drier ; Farm Machinery and Postharvest Process Engineering Division, Bangladesh Agricultural Research Institute, Gazipur-1701, Bangladesh. Department of Farm Power and Machinery, Bangladesh Agricultural University, Mymensingh-2202, Bangladesh, June 2006.
- [5] F.K. Forson, M.A.A.Nazha, F.O. Akuffo,H.Rajakaruna. Design of mixed-mode natural convection solar crop dryers: Application of principles and rules of thumb; Department of Mechanical Engineering, Kwame Nkrumah University of Science and Technology, Kumasi, Ghana Department of Mechanical Engineering, De Montfort University, Queens Building, Leicester LE1 9BH, UK; Renewable Energy 32 (2007) 2306–2319; Received 9 August 2006; accepted 15 December 2006 Available online 22 February 2007
- [6] EL- Amin Omda Mohamed Akoy, Mohamed Ayoub Ismail, El-Fadil Adam Ahmed and W. Luecke. Design and Construction of A Solar Dryer for Mango Slices.
- [7] Ahmed Abed Gatea. Design, construction and performance evaluation of solar maize dryer; Department of Agricultural mechanization, College of Agriculture, University of Baghdad, Iraq; Journal of Agricultural Biotechnology and Sustainable Development Vol. 2(3), pp. 039-046, March 2010; Accepted 29 October, 2009.
- [8] Bukola O. Bolaji , Tajudeen M.A. Olayanju and Taiwo O. Falade. Performance Evaluation of a Solar Wind-Ventilated Cabinet Dryer; Department of Mechanical Engineering, The Federal University of Agriculture, P.M.B. 2240, Abeokuta, Nigeria; The West Indian Journal of Engineering Vol.33, Nos.1/2, January 2011, pp.12-18; (Received 11 August 2005; Accepted January 2011).
- [9] Bukola O. Bolaji and Ayoola P. Olalusi. Performance Evaluation of a Mixed-Mode Solar Dryer; Department of Mechanical Engineering, University of Agriculture Abeokuta, Ogun State, Nigeria; AU J.T. 11(4): 225-231 (Apr. 2008).
- [10] Mohanraj, P. CHANDRASEKAR. Performance of a Forced Convection Solar Drier Integrated With Gravel As Heat Storage Material For Chili Drying; School of Mechanical Sciences, Karunya University, Coimbatore - 641114. India, School of Engineering and Sciences, Swinburne University of Technology (Sarawak Campus), Kuching Sarawak- 93576 Malaysia; Journal of Engineering Science and Technology Vol. 4, No. 3 (2009) 305 – 314.

### BIOGRAPHIES



Prof. Nitesh Ambadas Pachpor  
Assistant Professor at the college  
of Agriculture Engineering and  
Technology, Saralgaon, Thane



Prof. Priti Prakash Lad  
Assistant Professor at the college  
of Agriculture Engineering and  
Technology, Saralgaon, Thane