

Seismic Response of G+10 RC Multi-story Building with and without the effect of infill wall using IS 1893 (part 1): 2016

Kallesh K N¹, Dr. K Manjunatha², Prof V S Jagadeesh³

¹PG Scholar, Department of civil engineering, University of B D T College of Engineering, Davanagere, Karnataka.

²Professor, Department of civil engineering, University of B D T College of Engineering, Davanagere, Karnataka.

³Chief Structural Engineer, Jagadeesh Associates, Chitradurga, Karnataka.

Abstract – This research study investigate the linear dynamic of RC Regular (square shape) and Irregular (L & Plus shape) building connected with and without the effect of infill walls. The method carried out in terms of equivalent static and time history analysis, the infill wall adopted as equivalent diagonal strut of URM (Un-Reinforced masonry) infill wall mechanism according to IS 1893 (part 1): 2016 code. G+10 storey buildings respectively are considered for the analysis. In this analysis for infill buildings, the diagonal strut of URM infill walls are connected outer walls of all the buildings. The comparison of equivalent static and time history method by using finite element software packages ETABS 2015 is used to perform the modelling analysis of G+10 storey buildings by considering the seismic zone V as per IS 1893 (part 1): 2016. From the results, it is concluded that time period, storey displacement, story drift are less for the building with infill walls and base shear is more for the buildings with infill walls.

Key Words: A/L Ratio, Re-entrant Corner, URM-Un Reinforced Masonry infill, Equivalent Static analysis, Time History analysis, Bhuj Ground Motion.

1. INTRODUCTION

Masonry infills are normally considered as non-structural element and their effects are generally ignored in practice. As recent studies have shown, a properly designed infilled frame can be superior to bare frame in terms of stiffness, strength and energy dissipation. The interaction of the masonry infill's with the surrounding frame has a major influences on the structural response of the full composite structure. The masonry infill is stiff and has sizeable strength. Unreinforced masonry is used in frame building structures as infill, where it is intended to act as an environmental divider rather than as a structural element. During earthquake, the infills are subjected to in-plane as well as, out-plane forces. The in-plane forces are resisted by the infill through strut and shearing action, while out-plane forces are resisted by two way action of the infill between the floors and columns.

Studied the effect of masonry walls on high rise building. Linear and non-linear static analysis, a multistoried building frame consisting G+4, G+6, G+9, G+12, G+20. Lateral displacement is observed in non-linear analysis compared

with linear analysis for building height of 21m both the analysis resulted the same value increased by 0.81% for 31.5m, 1.38% for 42m, and 13.2% for 70m [1]. The dynamic characteristics of reinforced concrete moment-resisting frame building. In this paper different building models have been developed to perform the analysis. Bare frame without infill. Frame models with infill panels and soft storey located at base level, 3rd storey level, 6th storey level, 9th storey level, and 12th storey level. The equivalent diagonal strut method has been utilized in order to account for the stiffness and structural action of the masonry infill panels. Dynamic time history, using two ground motions records (El Centro & Loma prieta) [2]. Seismic performance of regular setback frame in combination with vulnerable layout of masonry infill wall over the frame elevation (i.e. probable case of "vertical stiffness irregularity"). Non-linear time history analysis and capacity spectrum method have been implemented to investigate the seismic performance of these frames [3].

In this paper, considered the effect of plan irregularity (re-entrant corner of L & plus shape building) of high rise buildings with infill walls. In this work the implementation of equivalent diagonal strut of URM (Un-Reinforced Masonry) infill wall mechanism as per IS 1893 (Part 1): 2016, has been considered in the analysis. The irregular plans with re-entrant corners (L & Plus). As per the specification given in IS 1893:2016 (part 1) (figure 1) [9].

2 BUILDING MODELS

In ordered to seismically investigate frame building without infill wall and with fully infill wall as frame building, a eleven storey reinforced concrete building with square shape, L shape building with A/L Ratio is 0.6 & plus shape building with A/L Ratio is 0.2

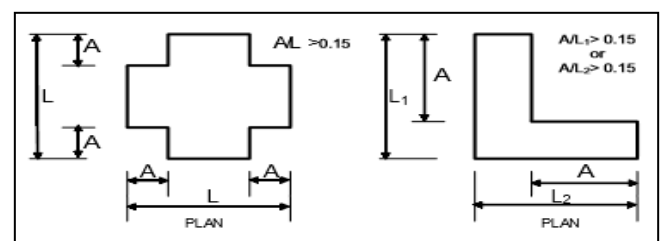

Fig: 1 Re-entrant corners as per IS 1893:2016(part1)

The considered building has a width of 25m divided into 5 bays in X & Y direction each bay is 5m. The dimensions of various member, loads, other specification are given in table 1, 2, 3, & 4

Table: 1 Description of RC building

Number of storeys	Height of each storey(m)	Column size (mm)	Beam size (mm)	Slab thickness (mm)
G+10	3	450x450	300x450	150
Wall thickness 230mm				

Table 2: material properties

Number of storeys	G+5 & G+10
Grade of concrete	M30
Grade of steel	Fe 500
Density of concrete	25 KN/m ³
Young's modulus of concrete	27386.12788x10 ³ KN/m ³
Poissons ratio of concrete	0.2
Compressive strength of brick as per IS 1077-1992	5 N/mm ²
Density of brick masonry	18.5 KN/m ³
Compressive strength of mortar as per IS-1905-1987 M ₂ (1:6)	3 N/mm ²

Table: 3 seismic parameters

Building frame system	Seismic zone	Soil type	Response reduction factor	Importance factor
SMRF	V	Type-II	5	1.2
Damping of structure 5%				

Table: 4 assumed load intensities

Roof	
Live load	2 KN/m ²
Floor finish	1.5 KN/m ²
Wall load (SIDL)	3.83 KN/m
Typical floors	
Live load	3 KN/m ²
Floor finish	1.5 KN/m ²
Wall load (SIDL)	10.85 KN/m

The following six different models are investigated in the study

Model-1: without infill (Bare frame) square shape plan.

Model-2: with infill square plan modelled as equivalent diagonal strut.

Model-3: without infill (Bare frame) L-shape plan.

Model-4: with infill L-shape plan modelled as equivalent diagonal strut.

Model-5: without infill (Bare frame) plus shape plan.

Model-6: with infill plus shape plan modelled as diagonal strut.

ETABS software is used to perform the dynamic analysis following the Indian code for loads, fig 2, 3, 4 & 5 shows a plans of a building.

3 MODELLING OF MASONRY INFILL WALL

Many researchers have found that the presence of the infill walls in the RC frame structures increases its stiffness and lateral load carrying capacity. Hence to assess the exact behaviour of the infill RC frame structures during the earthquakes, the masonry infill wall has to be modelled properly. One of the methods suggested by the researchers is the equivalent compression diagonal strut. Because of its simplicity it is adopted in the IS-1893 (Part 1)-2016 and in the present study the masonry infill walls are modelled as equivalent diagonal struts. The action of the equivalent diagonal struts during the earthquakes is shown in fig. 6

Compressive strength of masonry prism (f_m), compressive strength of brick (f_b), compressive strength of mortar (f_{mo})

$$f_m = 0.433 f_b^{0.64} f_{mo}^{0.36} = 0.433 * 5^{0.64} * 3^{0.36} = 1.80 \text{ Mpa}$$

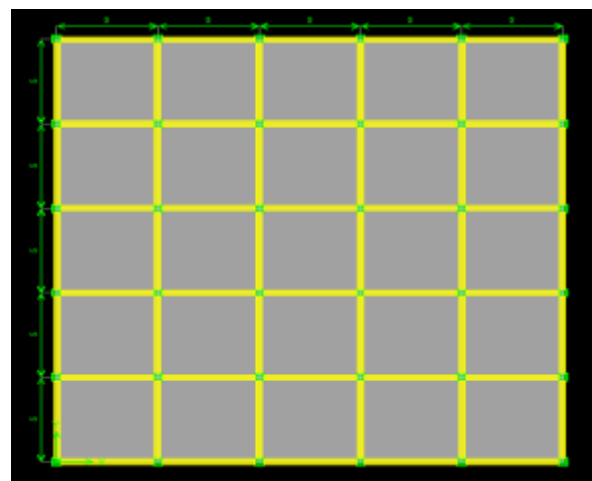

Fig: 2 plan of square shape building

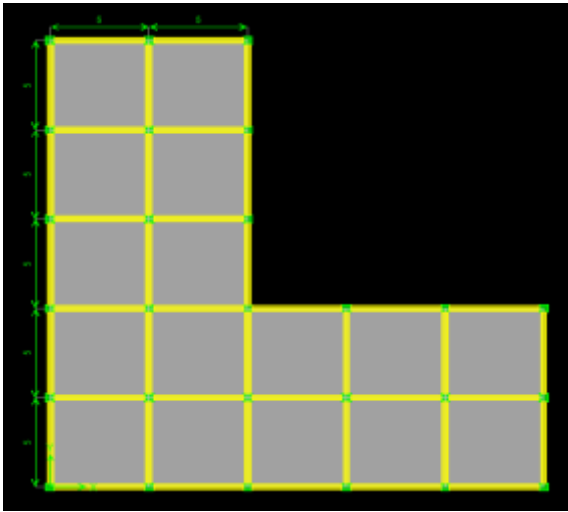

Fig: 4 plan of L- shape building

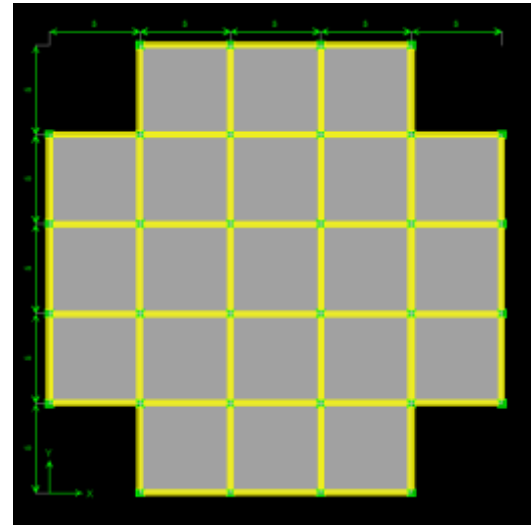

Fig: 5 plan of plus- shape building

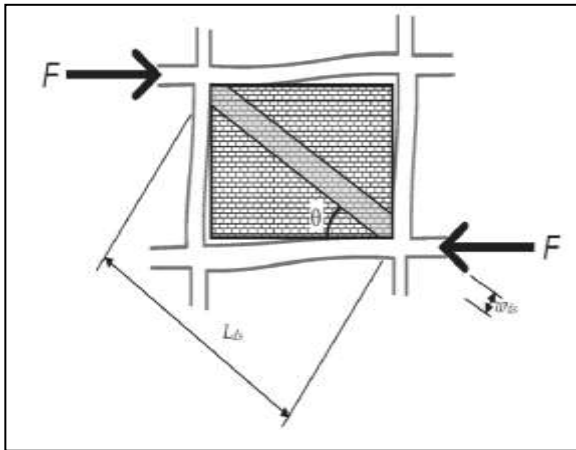

Fig: 6 modelling of masonry infill wall as equivalent diagonal strut of URM infill wall

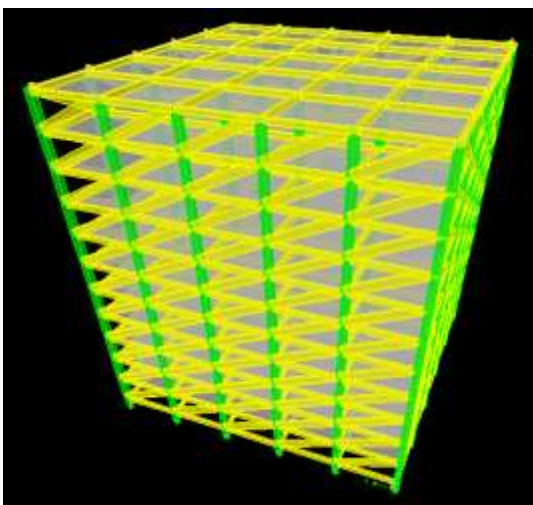

Fig: 3 modelling of equivalent diagonal struts

Modulus of elasticity of masonry (E_m)

$$E_m = 550 \cdot f_m = 550 \cdot 1.80 = 990.73 \text{ Mpa}$$

h = height of infill panel = $3000 - 450 = 2550 \text{ mm}$

t = thickness of URM infill wall = 230 mm

I_c = moment of inertia of column = $1647.94 \times 10^6 \text{ mm}^4$.

L_{ds} = diagonal length of masonry infill panel

$$L_{ds} = \sqrt{(2550^2 + 4625^2)} = 5281.84 \text{ mm.}$$

θ = angle made by masonry infill's diagonal with the horizontal in Degree i.e. $\tan^{-1}(h/l)$

$$\theta = \tan^{-1}(2550/4550) = 29.26$$

$$\alpha_h = h \left(\frac{E_m \cdot t \cdot \sin 2\theta}{4 \cdot E_f \cdot I_c \cdot h} \right)^{0.25}$$

$$\alpha_h = 2500 \cdot \left(\frac{990 \cdot 230 \cdot \sin 2(29.26)}{4 \cdot 27386.12 \cdot 106 \cdot 2550} \right)^{0.25} = 1.7125$$

$$W_{ds} = 0.175 \alpha_h^{-0.4} L_{ds}$$

$$W_{ds} = 0.175 \cdot 1.7125^{-0.4} \cdot 5281.84 = 736.17 \text{ mm}$$

4 METHODOLOGY FOR SEISMIC EVALUATION

4.1 Equivalent static analysis.

As per this method, first, the design base shear V_B shall be computed for the building as a whole. Then, this V_B shall be distributed to the various floor levels at the corresponding centre of mass. And, finally, this design seismic force at each floor level shall be distributed to individual lateral load resisting element through structural analysis considering the floor diaphragm action.

Following procedure is generally used for the analysis according to IS 1893 – 2002.

- i) Calculation of lumped weight.
- ii) Calculation of fundamental natural period. The fundamental natural period of vibration (Ta) in seconds of a moment resisting frame building,

$$T_a = 0.075 h^{0.75} \text{ (without brick infill panels)}$$

$$T_a = \frac{0.09h}{\sqrt{d}} \text{ (with brick infill panels)}$$

Where

h = Height of the building

d = Base dimension of the building at the plinth level in m, along the considered direction of the lateral force.

- iii) Determination of base shear (VB) of the building. $V_B = A_h \times W$

$$A_h = \frac{Z I \left(\frac{S_a}{g}\right)}{2R}$$

Where,

A_h is the design horizontal seismic coefficient, which depends on the seismic zone factor (Z), importance factor

(I), response reduction factor (R) and the average response acceleration coefficient (S_a/g). S_a/g in turn depends on the nature of foundation soil (rock, medium or soft soil sites), natural period and the damping of the structure.

- iv) Lateral distribution of design base shear;

The design base shear V_B thus obtained is then distributed along the height of the building using a parabolic distribution expression:

$$Q_i = \left(\frac{W_i h_i^2}{\sum_{j=1}^n W_j h_j^2} \right) V_B$$

Where Q₁ is the design lateral force, W₁ is the seismic weight, h₁ is the height of the ith floor measured from base and n is the number of stories in the building.

4.2 Linear Time history analysis

It is an analysis of the dynamic response of the structure at each instant of time, when its base is subjected to a specific ground motion time history.

Time-history analysis provides for linear evaluation of dynamic structural response under loading which may vary according to the specified time function. Dynamic equilibrium equations, given by

$K u(t) + C \frac{d}{dt} u(t) + M \frac{d^2}{dt^2} u(t) = r(t)$, are solved using either modal or direct-integration methods.

Where K is the stiffness matrix; C is the damping matrix; M is the diagonal mass matrix; u, $\frac{d}{dt} u$, and $\frac{d^2}{dt^2} u$ are the displacements, velocities, and accelerations of the structure; and **r** is the applied load. If the load includes ground acceleration, the displacements, velocities, and accelerations are relative to this ground motion. Figure 7 shows the acceleration time histories for the bhuj earthquake ground motion is used in the current analysis. The ground motion records are obtained from the PEER strong motion database and VDC strong motion virtual data center.

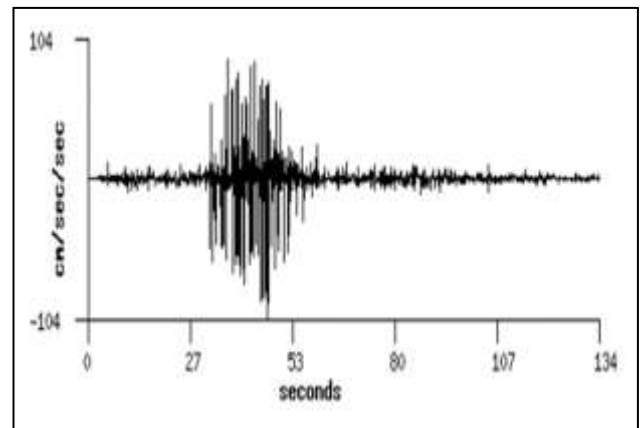

Fig: 7 Bhuj acceleration Jan 26, 2001, recording site Ahmedabad.

5 RESULTS AND DISCUSSIONS

The results are obtained from regular and irregular (re-entrant corner) building with and without infill walls models considered for Equivalent static analysis and Linear Time-History analysis as per IS 1893 (part 1): 2016. The results are presented with respect to parameters considered in the present study such as Base Shear, Lateral Displacement, and Storey drift.

5.1 Base shear

Base shear is an estimate of the maximum expected lateral force that will occur due to seismic ground motion at the base of a structure.

Chart 1 represents the comparison of Base Shear for G+10 storied building with and without infill wall in X direction for both Equivalent static (Zone-V) and Time history analysis (Bhuj Earthquake).

1) The Base Shear is a function of mass, stiffness, height & Natural period of building structure. But the Equivalent static method considers only the mass and natural period of the building. Moreover the basic assumption in the Equivalent Static method is that only first mode of vibration of building governs the dynamics.

2) In linear dynamic analysis (Time history analysis), all the modes of the building are considered, and first mode governs in the shorter buildings and as the story increases for tall buildings, the flexibility increases and higher modes come in to picture. Hence Base Shear obtained from the Equivalent Static method are less than the time history method.

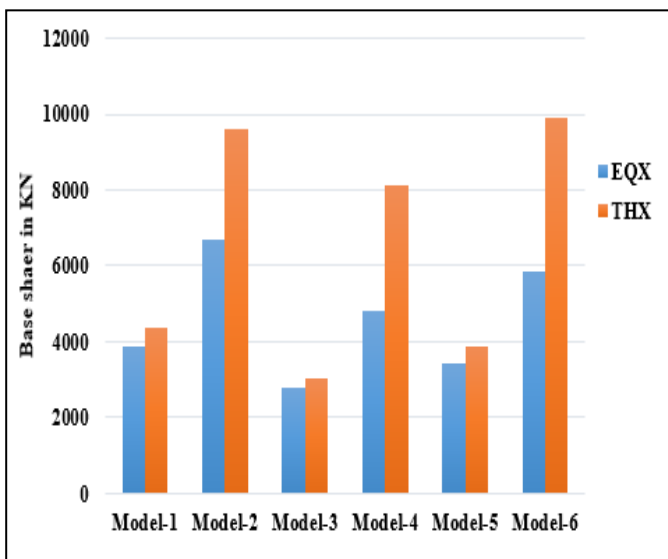

Chart-1 Base shear for G+10 storey building for different models in X direction

3) From the above chart-1 it is evident that when the story height goes on increasing the Base Shear increases and also when we provide infill walls, the Base Shear also increases

5.2 Lateral Displacement

Chart-1 and Chart-2 represent the variation of storey displacement of regular and irregular models in G+10 EQX & THX in X-direction.

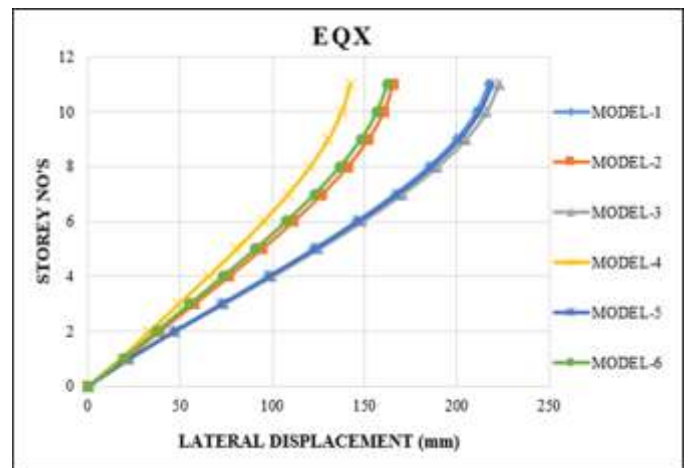

Chart-2 Variation of storey displacement for G+10 storeyed building for different models in X-Direction for EQX method

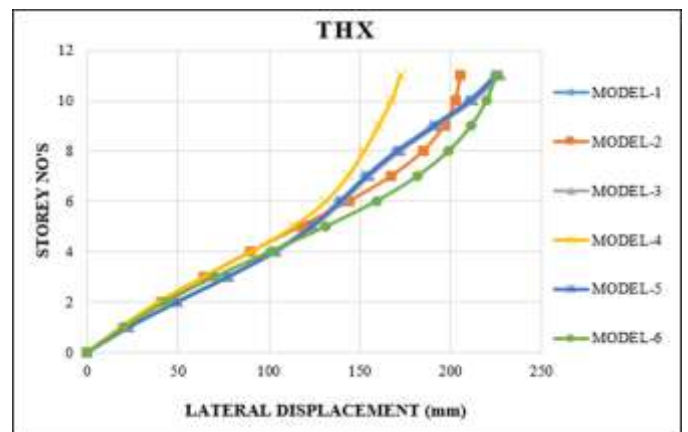

Chart-3 Variation of storey displacement for G+10 storeyed building for different models in X-Direction for THX method

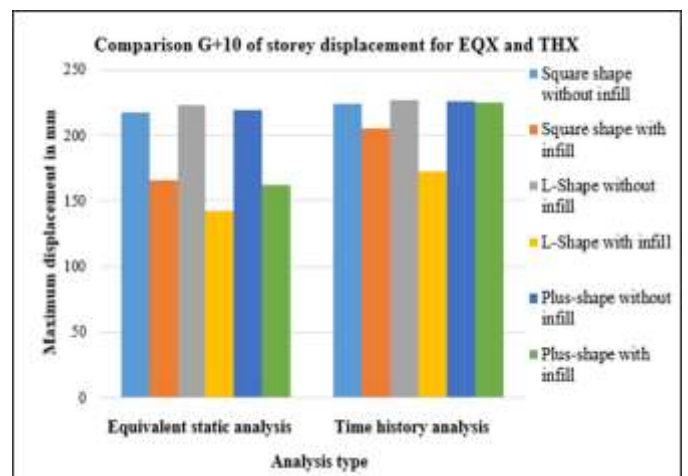

Chart-4 comparison of G+10 maximum storey displacement for equivalent static and linear time history analysis

1) The maximum storey displacement for G+10 for equivalent static analysis the displacement is less compared to without infill models of about 23.85%, 36.21%, & 25.98% in EQX direction, with infill Square, L & Plus shapes structures respectively.

2) Similarly for G+10 time history analysis the displacement is less compared to without infill models of about 8.28%, 24.19% & 0.28% in THX direction, with infill Square, L & Plus shape structures respectively.

3) With infill structures are most stable compared to without infill structures considered for the analysis, because of high stiffness (rigid) the lateral load resisting capacity is more hence the displacement is less.

4) Chart-4 show the comparison of G+10 maximum storey displacement of time history analysis which is greater than equivalent static analysis.

5) Lateral displacement increases as the number of stories increases, so that lateral displacement can be reduced by providing infill walls in the building.

5.3 Story Drift

It is the relative displacement between the floors above and/or below the storey. The permissible limit for storey drift of any building as per IS 1893 (Part 1):2016 is given by 0.04 times the storey height.

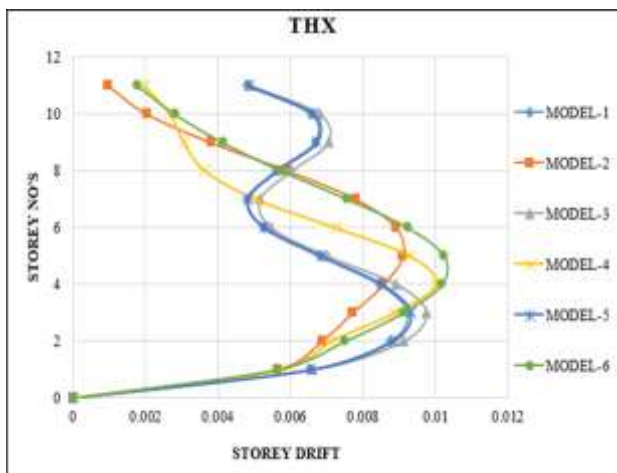

Chart-5 Variation of storey drift for G+10 storeyed building for different models in X-Direction for EQX method

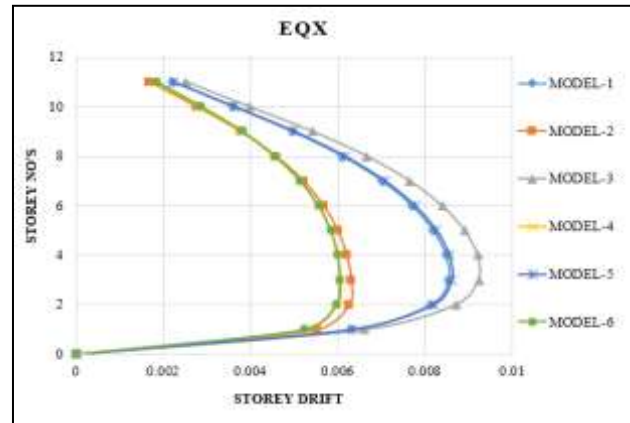

Chart-6 Variation of storey drift for G+10 storeyed building for different models in X-Direction for THX method

1) From Chart-5 to Chart-6 it is observed that due to presence of infill walls the storey drift of the building decreases.

2) As we observed that if displacement is more storey drift also more, because of high flexibility in the bare frame (without infill) structure. Similarly the displacement is less storey drift also less, because of high stiffness in the with infill structure.

3) For a structure with URM equivalent diagonal strut infill walls are less vulnerable to seismic forces as compared to bare frame structure due to stiffness caused by the infill walls.

6 CONCLUSION

The present study is focused on the study of seismic behavior of RC buildings using analytical techniques for the building located in the seismic zone-V of Indian medium soil. The performance of the building is studied in terms of Base shear, Lateral displacement and storey drift in Linear static and linear Dynamic (Time-History) analysis for with and without the effect of infill wall G+10 storey building with Regular (square) plan and Irregular (L-shape & plus Shape) plan.

The following conclusions are made from the present study are

1) The natural time period goes on increasing as the building height goes on increasing, this is also true when we provide Un-reinforced masonry (URM) infill walls in the building the natural time period of the building decreases.

2) Base shear of the structures with URM infill wall is increased compared to bare frame (without infill wall) in X-direction. This increase in base shear is due to increase in the seismic weight of the building.

3) Providing URM infill walls in the building results in drastic reduction of lateral displacement of the building, there by

increases the resistance and safety of the structure against seismic forces.

4) The lateral displacement of the model 6, i.e. Plus shape building with URM infill wall displacement is less compared to all other models.

5) Base shear obtained from the equivalent static 6) Unreinforced masonry (URM) infills provides strength and stiffness to the building, story drift decreases significantly. The storey drifts was found to be more in the lower and middle storeys.

REFERENCES

[1]. **B Pallavi and A Mallika [2017]**. Comparative study on seismic response of multistorey building frame with infills using linear and non-linear analysis" i-manager's journal on structural engineering. Volume-6, No: 1, March-May 2017 PP: 39-44.

[2]. **Sayed Mahmoud, Magdy Genidy and Hesham Tahooun [2017]**. "Time history analysis of reinforced concrete frame building with soft storeys". Arab. J Sci-Eng. (springer) March 2017, Volume 42, Issue-3, PP: 1201-1217.

[3]. **Arshad K & Hashmi [2016]**. "Seismic evaluation and preliminary design of rectangular setback masonry infilled open ground storey RC frame". J Inst. Eng. India. A. (Springer) April-June 2016. Volume-97(2), PP: 121-131.

[4]. **Bhuwan Singh & K Venkata Ramesh [2017]**. "Comparison of reinforced frame concrete frame modelled with and without infill wall". International journal of Civil Engineering and Technology (IJCEIET), Volume-8, Issue-8, August 2017, PP: 1636-1644.

[5]. **Khubaib Ilyas Khan M & Saim Raza [2015]**. "Seismic performance assessment of masonry infilled reinforced concrete frame structure". International journal of civil & structural engineering (ISSN 0976-4399), August 2015.

[6] **Manju G 2014** "Dynamic analysis of infills on RC framed structures- International journal of innovative research in science, engineering and technology (ISSN: 2319-8753) vol.3, issue 9, September 2014.

[7]. **T Mahdi & V Bahreini [2013]**. "Seismic response of Asymmetric infilled concrete frames". Procedia engineering Volume: 54, PP-341-352. The 2nd international conference on rehabilitation and maintenance in civil engineering.

[8]. **Haroon Rasheed Tamboli and Umesh N Karadi [2012]**. "Seismic analysis of RC frame structure with and without masonry infill walls". Indian journal of natural sciences, ISSN: 0976-0997, Volume-3, October 2012.

9. IS: 1893-2016 (Part 1), "Criteria for earthquake resistant design of structures, General provisions and buildings", Bureau of Indian Standards, New Delhi.

10. IS: 1905-1987, "Code of Practice for Structural use of Unreinforced Masonry", Bureau of Indian Standards, New Delhi.

BIOGRAPHIES



Kallesh K N: M.Tech Scholar at UBDTCE Davanagere, presently working as Associate Structural engineer Jagadeesh Associates, Chitradurga.



Dr. K Manjunatha is working as professor in the department of civil engineering at UBDTCE Davanagere, & also Regional Director, VTU, Mysore Region.



Prof V S Jagadeesh, post graduate in Industrial structure in 1987. Is chief Structural consultant in Jagadeesh Associates Chitradurga, Has given Structural Consultant services both India and abroad & is Expertise in construction & management of structures in Expensive soil.