

# PRACTICAL ORIENTED FOOT STEP ELECTRIC POWER GENERATION BY USING PIEZO MATERIAL AND MICROCONTROLLER IN CAMPUS

K. NARESH<sup>1</sup>, A. BALAJI<sup>2</sup>, M. RAMBABU<sup>3</sup>, G. NAGARAJU<sup>4</sup>

*<sup>1,2,3,4</sup>Assistant Professors in Department of Electrical and Electronics Engineering, Usha Rama College of Engineering and Technology*

-----\*\*\*-----

**Abstract** - The decrease in energy consumption of portable electronic devices, the concept of harvesting renewable energy in human surrounding arouses a renewed interest. This technical paper focuses on one such advanced method of energy harvesting using piezoelectric material. Piezoelectric materials can be used as mechanisms to transfer mechanical energy, usually ambient vibration, into electrical energy that can be stored and used to power other devices. A piezoelectric substance is one that produces an electric charge when a mechanical stress is applied. Conversely, a mechanical deformation is produced when an electric field is applied. Piezo-film can generate enough electrical density that can be stored in a rechargeable battery for later use. Piezoelectric materials have a vast application in real fields. Some of the latest applications are mentioned below. Currently, there is a need to utilize alternative forms of energy at passenger terminals like airports and railways across the world. Cleaner, more sustainable forms of electrical power are needed in order to keep costs lower, to maintain positive and productive relationships with neighbors and to insure a healthier environment for future generations. The use of piezoelectric devices installed in terminals will enable the capturing of kinetic energy from foot traffic. This energy can then be used to offset some of power can be used to operate lighting systems. In last few years low power electronic devices have been increased rapidly. The devices are used in a large number to comfort our daily lives. With the increase in energy consumption of these portable electronic devices, the concept of harvesting alternative renewable energy in human surroundings arise a new interest among us. In this project i try to develop a piezoelectric generator. That can produce energy from vibration and pressure available on some other term (like people walking). This project describes the use of piezoelectric materials in order to harvest energy from people walking vibration for generating and accumulating the energy. This concept is also applicable to some large vibration sources which can find from nature. This project also represents a footstep of piezoelectric energy harvesting model which is cost effective and easy to implement

**Key Words:** Piezoelectric material, battery, external pressure, led, microcontroller.

## 1.INTRODUCTION

For an alternate method to generate electricity there are number of methods by which electricity can be

produced, out if such methods footstep energy generation can be an effective method to generate electricity. Walking is the most common activity in human life. When a person walks, he loses energy to the road surface in the form of impact, vibration, sound etc, due to the transfer of his weight on to the road surface, through foot falls on the ground during every step. This energy can be tapped and converted in the usable form such as in electrical form. This device, if embedded in the footpath, can convert foot impact energy into electrical form. Ninety-five percent of the exertion put into pedal power is converted into energy. Pedal power can be applied to a wide range of jobs and is a simple, cheap, and convenient source of energy. However, human kinetic energy can be useful in a number of ways but it can also be used to generate electricity based on different approaches and many organizations are already implementing human powered technologies to generate electricity to power small electronic appliances [5]. Proposal for the utilization of waste energy of foot power with human locomotion is very much relevant and important for highly populated countries like India and China where mobility of its masses will turn into boon in generating electricity from its footsteps. In India, places like roads, railway stations, bus stands, are all over crowded and millions of people move round the clock. As a result large amount of power can be obtained with the use of this promising technology. This process involves number of simple setup that are installed under the walking platform. When people walk on this platform their body weight compresses the setup which rotates a dynamo or Sanyo coil and current produced is stored in dry battery. To reduce the external compression, a responsive sub - flooring system is installed. And while the power producing platform is over crowded with moving population, energy is produced at larger levels [2]. Greater movement of people will generate more energy. In this topic we are generating electrical power as non conventional method by simply walking or running on the foot step. Non conventional energy system is very essential at this time to our nation.

### 1.1 Objective

The basic objective would be to study the techniques of footstep generation and to successfully compare the methods that followed for each power generation. Modeling of this system and interfacing the electrical hardware would be the prime importance [1]. After designing, the obtained

parameters and design values (results) will help to implement it on hardware.

### 1.2 Study of Piezo Material

Piezoelectric ceramics belong to the group of ferroelectric materials. Ferroelectric materials are crystals which are polar without an electric field being applied. The piezoelectric effect is common in piezo ceramics like PbTiO<sub>3</sub>, PbZrO<sub>3</sub>, PVDF and PZT. The main component of the project is the piezoelectric material. The proper choice of the piezo material is of prime importance. For this, an analysis on the two most commonly available piezoelectric material - PZT and PVDF, to determine the most suitable material was done. The criterion for selection was better output voltage for various pressures applied. In order to understand the output corresponding to the various forces applied, the V-I characteristics of each material namely, PZT and PVDF were plotted [1]. For this the Piezo transducer material under test is placed on a Piezo force sensor. Voltmeters are connected across both of them for measuring voltages and an ammeter is connected to measure the current. As varying forces are applied on the Piezo material, different voltage readings corresponding to the force is displayed. For each such voltage reading across the force sensor, various voltage and current readings of the Piezo test material are noted. The voltage from PZT is around 2 V where as that of PVDF is around 0.4V. We can thus conclude that better output is obtained from the PZT than the PVDF.

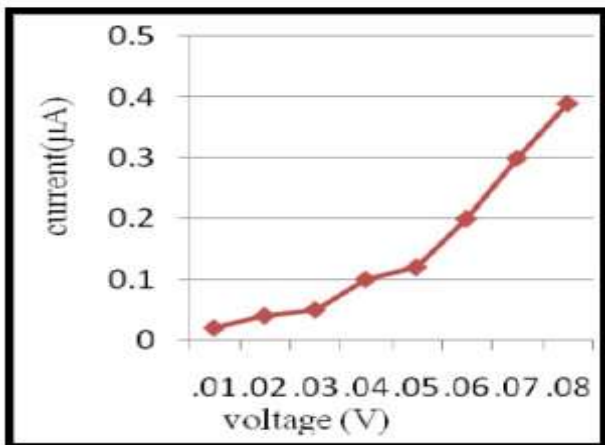

Fig -1: V-I Characteristic for PVDF Material

### 1.3 Study of Connection

Next to determine the kind of connection that gives appreciable voltage and current necessary, three PZT are connected in series. A force sensor and voltmeter is connected to this series combination. As varying forces are applied on this connection, corresponding voltages are noted. Also the voltage generated across the series connection and the current is measured.

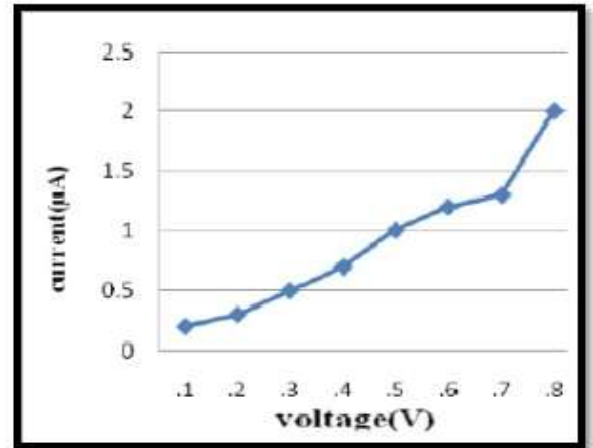

Fig -2: V-I Characteristic for PZT

Similarly the connections are done for parallel and series-parallel connections are done and the graphs are as in figures. It can be seen from the graph that the voltage from a series connection is good but the current obtained is poor, whereas the current from a parallel connection is good but the voltage is poor. But this problem is rectified in a series - parallel connection where a good voltage as well as current can be obtained [4].

### 1.4 Maximum Theoretical Power Generation

When a force is applied on piezo material, a charge is generated across it. Thus, it can be assumed to be an ideal capacitor. Thus, all equations governing capacitors can be applied to it. In this project, on one tile, we connect 3 piezo in series. 10 such series connections are connected in parallel. Thus when 3 piezoelectric discs are connected in series, its equivalent capacitance becomes hence, the net voltage generated in series connection is the sum of individual voltages generated across each piezoelectric disc. Output voltage from 1 piezo disc is 13V. Thus the maximum voltage that can be generated across the piezo tile is around 39V.

### 2. SYSTEM DESCRIPTION AND WORKING

The basic working principle of this project is based on the piezoelectric sensor. To implement this we adjust the wooden plates above and below the sensors and moveable springs [3]. Non-conventional energy using foot step is converting mechanical energy into the electrical energy. Foot step board it consist of a 16 piezo electric sensors which are connected in parallel [10]. When the pressure is applied on the sensors, the sensors will convert mechanical energy into electrical energy. This electrical energy will be storing in the 12v rechargeable battery connected to inverter. We are using conventional battery charging unit also for giving supply to the circuitry. This inverter is used to convert the 12 Volt D.C to the 230 Volt A.C. This 230 Volt A.C voltage is used to activate the loads. By using this AC voltage we can operate AC loads.



Fig -3: PZT in series connection

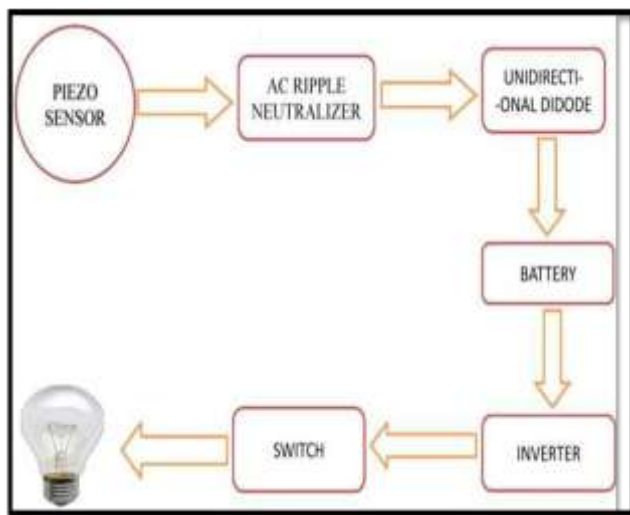

Fig -4: Block diagram of footstep generator

### 2.1 Model of Foot Step Energy Generation

The working of the Foot Stop Electric Converter (FSEC) is demonstrated in photographs in the right side photograph shows the foot touching the top plate without applying weight. The left side Photograph shows the foot when full weight of the body is transferred to the top plate. A 6 W, 12V bulb connected to the output of the alternator glows, to indicate the electric output when foot load is applied. The unit is designed to generate full power pulse when actuated by a person weighing nearly 60 kg. An experimental plot of voltage vs. time was generated, by using an oscilloscope [11]. Using voltage data and the load (a resistor), a typical plot of power vs. time was generated. The power generated by the foot step generator can be stored in an energy storing device. The output of the generator was fed to a 12 V lead acid battery, through an AC - DC converter bridge. Initially, the battery was completely discharged. Then, the FSEC was operated by applying foot load and energy was stored in the battery. A 100 W, 230V bulb was connected to the battery

through an inverter. The duration of lighting, the bulb for number of footsteps and corresponding energy stored, are given in Table 1.



Fig -5: Footstep Power Generation System

### 2.2 Energy Storing Table

The power generated by the foot step generator can be stored in an energy storing device. The output of the generator was fed to a 12 V lead acid battery, through an ac-dc converter bridge. Initially, the battery was completely discharged. Then, the FSEC was operated by applying foot load and energy was stored in the battery. A 100 W, 230V bulb was connected to the battery through an inverter. The arrangement is shown in Fig. 6. The duration of lighting, the bulb for number of footsteps and corresponding energy stored, are given in Table 1. The piezoelectric material converts the pressure applied to it into electrical energy. The source of pressure can be either from the weight of the moving vehicles or from the weight of the people walking over it [9]. The output of the piezoelectric material is not a steady one. So a bridge circuit is used to convert this variable voltage into a linear one. Again an AC ripple filter is used to filter out any further fluctuations in the output. The output dc voltage is then stored in a rechargeable battery. As the power output from a single piezo-film was extremely low, combination of few Piezo films was investigated. Two possible connections were tested - parallel and series connections. The parallel connection did not show significant increase in the voltage output. With series connection, additional piezo - film results in increased of voltage output but not in linear proportion. So here a combination of both parallel and series connection is employed for producing 40V voltage output with high current density. From battery provisions are provided to connect dc load [7]. An inverter is connected to battery to provide provision to connect AC load. The voltage produced across the tile can be seen in a LCD.

## 2.2 Maximum Voltage Generated

When a force is applied on piezo material, a charge is generated across it. Thus, it can be assumed to be an ideal capacitor. Thus, all equations governing capacitors can be applied to it. In this project, on one tile, we connect 3 piezo in series. 10 such series connections are connected in parallel. Thus when 3 piezoelectric discs are connected in series, its equivalent capacitance becomes: Hence, the net voltage generated in series connection is the sum of individual voltages generated across each piezoelectric disc. Output voltage from 1 piezo disc is 13V. Thus,  $=13+13+13 = 39V$

Thus the maximum voltage that can be generated across the piezo tile is around 39V.

**Table -1:** Energy Storage Chart

S. No	No. of Foot Steps	Duration of lighting a 100W, 230V bulb(S)	Total Energy(J)	Energy/step(J)
1	250	6	600	2.4
2	500	12	1200	2.4
3	750	18	1800	2.4
4	1000	25	2500	2.5

## 2.3 Piezoelectric Sensor

A piezoelectric sensor is a device that uses the piezoelectric effect to measure pressure, acceleration, strain or force by converting them to an electrical signal. Piezoelectric sensors have proven to be versatile tools for the measurement of various processes. They are used for quality assurance, process control and for research and development in many different industries it was only in the 1950s that the piezoelectric effect started to be used for industrial sensing applications. Since then, this measuring principle has been increasingly used and can be regarded as a mature technology with an outstanding inherent reliability [6]. It has been successfully used in various applications, such as in medical, aerospace, nuclear instrumentation, and as a pressure sensor in the touch pads of mobile phones. In the automotive industry, piezoelectric elements are used to monitor combustion when developing internal combustion engines. The sensors are either directly mounted into additional holes into the cylinder head or the spark/glow plug is equipped with a built in miniature piezoelectric sensor. The rise of piezoelectric technology is directly related to a set of inherent advantages. The high modulus of elasticity of many piezoelectric materials is comparable to that of many metals and goes up to  $10e6 N/m^2$  [Even though piezoelectric sensors are electromechanical systems that react to compression, the sensing elements show almost zero deflection. This is the reason why piezoelectric sensors are

so rugged, have an extremely high natural frequency and an excellent linearity over a wide amplitude range. Additionally, piezoelectric technology is insensitive to electromagnetic fields and radiation, enabling measurements under harsh conditions. Some materials used (especially gallium phosphate or tourmaline) have an extreme stability even at high temperature, enabling sensors to have a working range of up to  $1000^{\circ}C$ . Tourmaline shows piezoelectricity in addition to the piezoelectric effect. This is the ability to generate an electrical signal when the temperature of the crystal changes. This effect is also common to piezo ceramic materials. One disadvantage of piezoelectric sensors is that they cannot be used for truly static measurements. A static force will result in a fixed amount of charges on the piezoelectric material. While working with conventional readout electronics, imperfect insulating materials, and reduction in internal sensor resistance will result in a constant loss of electrons, and yield a decreasing signal [4,7,8].

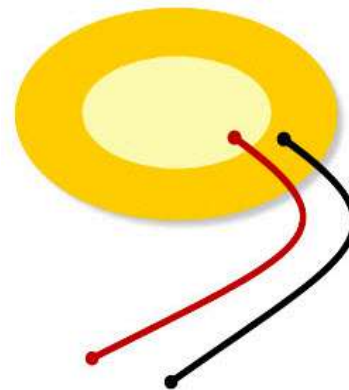

**Fig -6:** Piezoelectric Sensor

## 2.4 Battery Connection

Lead-acid batteries are normally available in blocks of 2V, 6V or 12V. In most cases, to generate the necessary operating voltage and the capacity of the batteries for the Solar Inverter, many batteries have to be connected together in parallel and/or in series.

## 2.5 Microcontroller

This project is used to generate voltage using footstep force. The proposed system works as a medium to generate power using force. This project is very useful in public places like bus stands, theaters, railway stations, shopping malls, etc. So, these systems are placed in public places where people walk and they have to travel on this system to get through the entrance or exist. Then, these systems may generate voltage on each and every step of a foot. For this purpose, piezoelectric sensor is used in order to measure force, pressure and acceleration by its change into electric signals. This system uses voltmeter for measuring output, led lights, weight measurement system and a battery for better

demonstration of the system. 1). whenever force is applied on piezoelectric sensor, then the force is converted into electrical energy. 2). In that movement, the output voltage is stored in the battery. 3). The output voltage which is generated from the sensor is used to drive DC loads. 4). Here we are using AT89S52 to display the amount of battery get charged.

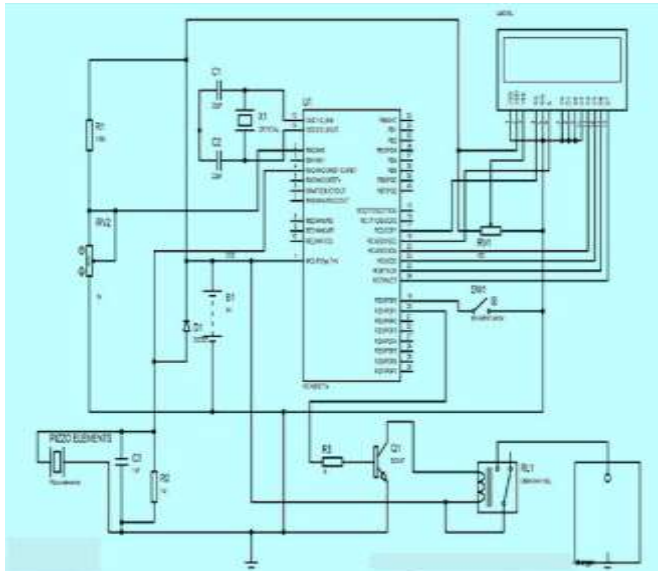

**Fig -7:** Footstep Power Generation System Circuit Diagram

This project uses the AT89S52 Microcontroller and Features of this microcontroller includes 8K bytes ROM, 256 bytes RAM 3 Timers, 32 I/O pins, one Serial port, 8 Interrupt sources Here we are using AT89S52 microcontroller to display the amount of battery get charged when we place our footstep on piezoelectric sensor.

### 3. PRACTICAL ARRANGEMENTS AND RESULTS

The project “POWER GENERATION USING FOOT STEP” is successfully tested and implemented which is the best economical, affordable energy solution to common people. This can be used for many applications in rural areas where power availability is less or totally absence As India is a developing country where energy management is a big challenge for huge population. By using this project we can drive both A.C. as well as D.C loads according to the force we applied on the piezo electric sensor. A piezo tile capable of generating 40V has been devised. Comparison between various piezo electric material shows that PZT is superior in characteristic s. Also, by comparison it was found that series-parallel combination connection is more suitable. The weight applied on the tile and corresponding voltage generated is studied and they are found to have linear relation.



**Fig -8:** Series and Parallel Connection Arrangement

It is especially suited for implementation in crowded areas. This can be used in street lighting without use of long power lines. It can also be used as charging ports, lighting of pavement side buildings. As a fact only 11% of renewable energy contributes to our primary energy. If this project is deployed then not only we can overcome the energy crises problem but this also contributes to create a healthy global environmental change.

Smart system produce 2000W electricity.

Durable have a life of approximately 5 years.



**Fig -9:** Spring action arrangement

Thus this is a promising technology to provide efficient solution to power crisis to affordable extent. This will be the most acceptable means of providing power to the places that involves difficulties of transmission. Moreover walking across a power producing platform then will be a fun for idle people who can improve their health by exercising in such



Fig -10: Final piezo material arrangement



Fig -13: A 19V indicator showing by this arrangement

Platforms with earning. The electrical energy generated at such farms will be useful for nearby applications. This technology would facilitate the future creation of new urban landscapes, athletic fields with a spectator area, music halls, theaters, nightclubs and a large gathering space for rallies, demonstrations and celebrations, railway stations, bus stands, subways, airports etc. like capable of harnessing human locomotion for electricity generation.



Fig -11: Force application generates force which charges battery



Fig -14: Force charges battery which turn lights the load

Table -2: Power Chart with force weight

S. No	Weight in Kg	Power in W
1	10	0.011
2	20	0.027
3	30	0.38
4	40	0.51
5	50	0.62
6	60	0.73

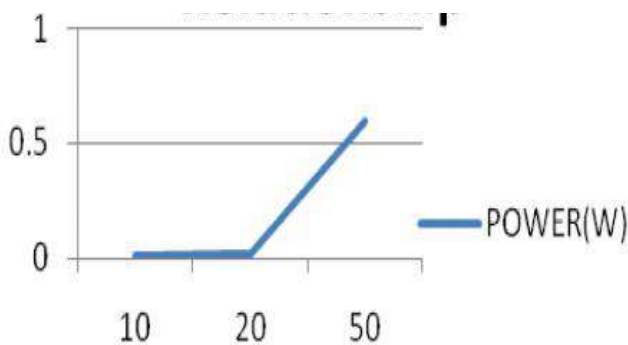

Fig -12: Weight versus power relationship

#### 4. CONCLUSIONS

From this review its very easy to understand the basic comparison and design criteria that used for the methods to generate the power using the footstep. In the method only electrical part places major role. Thus the method is quite easy to implement and maintain .Thus to make the whole system for urban area application more design parameters should consider.

The generation of energy and its use is one of the problems. Now-a-days numbers of energy sources are present, non-

renewable and renewable, but we still cannot exceed our energy needs. Among these, the human population is one of the resources. Energy can be generated by walking down the stairs. The energy generated will be stored and then we can use it for domestic purpose. This system can be installed in homes, schools, universities, where people move around the clock. When people walk on the rungs or platform, power is generated using the person's weight. The control mechanism carries piezoelectric sensor, this mechanical energy applied in the glass in electrical energy. When there are some vibrations, the effort or effort force is exerted on foot on a flat platform. "Design and develop an automatic toll plaza based on microcontroller, RFID technology and load sensor (piezoelectric sensor) to save time at the toll plaza and have cashless operation." As the name suggests "Automatic toll plaza" the key theme of this document is automation.

So in a very simple language, Automation means replacing the human process with machines. It means what the human is currently doing in the process now the machines are going to do. Before we go any further, we will just take a look at the history of the toll plazas. So before the 90s, the toll plazas were completely controlled manually.

## REFERENCES

- [1] A. Shiri, M. R. Alizadeh Pahlavani, H. A. Mohammadpour, and A. Shoulaie, "Electromagnetic Force Distribution on Cylindrical Coils' Body", PIERS proceedings, March 22-26, 2010.
- [2] Y.L.Chow, M.M.A.Salama and G.Djogo, "Thevenin source resistance of the touch transferred and step voltages of a grounding system", IEEE proceedings vol. 146, March 1999.
- [3] Yuki Bunda, Kajiro Watanabe, Kazuyuki Kobayashi, "Measurement of static electricity generated by human walking", SICE Annual conference 2010.
- [4] A. Mohammadpour A. Gandhi L. Parsa, "Winding factor calculation for analysis of back EMF wavefor in air core permanent magnet linear synchronous motors", IET Electric Power Applications 20th Sept, 2011.
- [5] Dailey, Sandra J. , Carpenter, William F., "The evolution of built-in test for an electrical power generating system (EPGS)", IEEE Aerospace and Electronics conference, vol. 1, no. 7, pp. 230-232, July 1989.
- [6] Li, Zheng; Mao, Shaohua; Zhu, Shi, "Numerical simulation reach of effect of external wind on flue gas movement pattern in high rise building vertical shaft", International Conference on multimedia technology vol. 3, pp.-4010-4013, 2011.
- [7] "Vibration Based Energy Harvesting Using Piezoelectric Material", M.N. Fakhzan, Asan

G.A.Muthalif, Department of Mechatronics Engineering, International Islamic University Malaysia, IIUM, Kuala Lumpur, Malaysia.

- [8] "Piezoelectric Crystals: Future Source Of Electricity", International Journal of Scientific Engineering and Technology, Volume 2 Issue 4, April 2013.
- [9] "Electricity from Footsteps", S.S.Taliyan, B.B. Biswas, R.K. Patil and G. P. Srivastava, Reactor Control Division, Electronics & Instrumentation Group And T.K. Basu IPR, Gandhinagar.
- [10] "Estimation of Electric Charge Output for Piezoelectric Energy Harvesting", LA-UR-04-2449, Strain Journal, 40(2), 49-58, 2004; Henry A. Sodano, Daniel J. Inman, Gyuhae Park. Center for Intelligent Material Systems and Structures Virginia Polytechnic Institute and State University.
- [11] " Design Study of Piezoelectric Energy- Harvesting Devices for Generation of Higher Electrical Power Using a Coupled Piezoelectric -Circuit Finite Element Method", IEEE Transactions on Ultrasonic's, Ferroelectrics, and Frequency Control, vol. 57, no. 2, February 2010.

## BIOGRAPHIE



K. Naresh is working as Assistant Professor in EEE-Dept. Usha Rama College of Engineering and Technology. He has more than 9-years teaching experience. His research area is Power System and Control System.