

Analysis of Power of a PV module with the help of Incremental Conductance MPPT and DC-DC Boost Converter

Anurag Rai¹, Bimal Garg²

¹Student, Madhav Institute of Technology & Science, Gwalior (M.P.)

²Associate Professor, Department of electronics engineering, Madhav institute of technology & science, Gwalior (M.P.)

Abstract- Solar energy is an important source of renewable energy and its technology are extensively characterized as both passive solar and active solar relying on how they capture and distribute solar energy or convert it into solar power. This paper presents the simulation and implementation of hardware of a photovoltaic module and then improved its yield power with the help of incremental conductance and a boost converter. The used MPPT (maximum power point tracking) is very much capable to work efficiently even in changed conditions of climate which is called as incremental conductance MPPT. The paper proposes the improvement in the power of photovoltaic module with the help of a MPPT technique and a boost converter. The improvement in yield power is achieved at different irradianations by keeping the temperature constant at 25 °C. The photovoltaic module along with MPPT controller and DC-DC boost converter has been simulated in Simulink/MATLAB and the hardware has been designed.

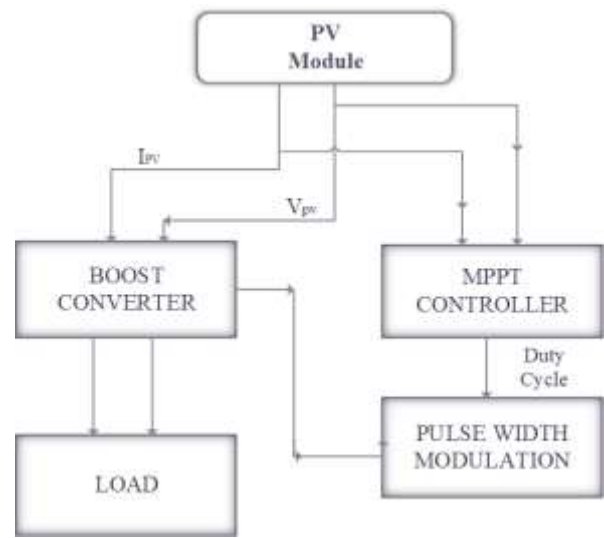

Fig.1 Proposed Photovoltaic System

Key words—Photovoltaic module, DC-DC Boost Converter, Incremental Conductance MPPT, Load.

1. INTRODUCTION

Solar energy is the kind of energy which is easily obtained from the sun light by imprisons the heat of the sun. As sun is the biggest source of energy so the technology has provided numerous ways to use the energy of this huge source. The precious advantage of solar energy is that it does not emit greenhouse gases and that is why it is also called as green technology. Solar energy is not only being used in electricity but it's also a useful source of heat. Solar energy can be classified as active solar and passive solar. The active solar basically deals with the photovoltaic system, solar power and water heating and the passive solar deals with the light dispersive property. Even after all such advantages solar energy is not as efficient as it should be and that is the reason why MPPT and converter is required in the proposed design [1]. Most of the MPPT technique is used to track the maximum power to improve the efficiency of photovoltaic module [2, 5, 7]. Converter is a DC-DC boost converter which used to boost up the voltage. There are various MPPT techniques but incremental conductance is best because of its adjustment with the sudden changes in climate.

Fig.1 shows the proposed photovoltaic system in which a solar panel is connected to a DC-DC power converter and a MPPT controller as well and the output of the converter is connected to the load [4]. In this paper the power of photovoltaic module has been improved by using this proposed methodology (Fig.1). And the improved power has been calculated for three different irradianations by keeping the temperature constant.

2. DESIGN OF A PHOTOVOLTAIC MODULE

In the designing of a photovoltaic module the various equations are used [2 & 6].

$$i_{pv} = n_p * i_{ph} - n_p * i_{rs} \left[\exp \left(\frac{qV_{pv}}{kTAn_s} \right) - 1 \right] \quad .. (1)$$

In equation (1), is the temperature of the cell, k represents the Boltzmann's constant, q represents the charge and i_{rs} is the reverse saturation current of the cell. A is the ideality factor of the diode.

$$i_{rs} = i_{rr} \left[\frac{T_c}{T_{ref}} \right] \exp \left(\frac{qE_G}{kA} \left[\frac{1}{T_{ref}} - \frac{1}{T_c} \right] \right) \quad ..(2)$$

In equation (2), T_{ref} is representing the cell reference temperature, i_{rr} is reverse saturation current of the cell and E_G is the band gap energy.

The photovoltaic current can be expressed as

$$i_{ph} = 0.01[i_{scr} + K_v(T_c - T_{ref})]G \quad \dots(3)$$

In equation (3), i_{scr} is the short circuit current of the cell, K_v is the temperature coefficient and G representing the irradiation in kW/m^2 .

The power of the photovoltaic module can be calculated with the help of equation (1) by multiplying by V_{pv} on both sides

$$P_{pv} = n_p * i_{ph} * v_{pv} - n_p * i_{rs} * v_{pv} [\exp(\frac{qV_{pv}}{kT_c An_s}) - 1] \quad \dots(4)$$

Now substitute the i_{ph} value from (3) in (4), and calculate P_{pv}

$$P_{pv} = 0.01 * n_p [i_{scr} + K_v(T_c - T_{ref})] * G * v_{pv} - n_p * i_{rs} * v_{pv} [\exp(\frac{qV_{pv}}{kT_c An_s}) - 1] \quad \dots(5)$$

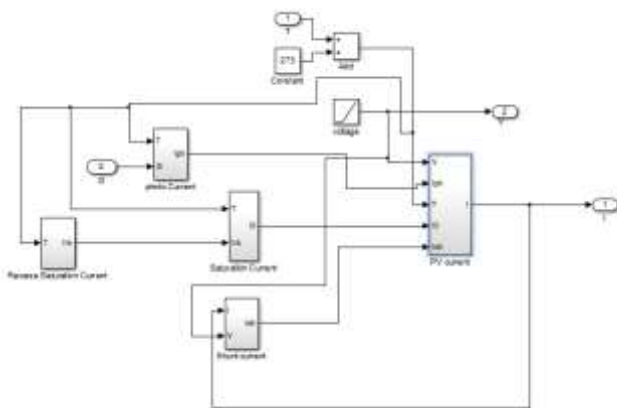

Fig.2 Design of equations (1-5) using Simulink/MATLAB

Fig.2 is the design of the equations used for photovoltaic module. They have been design using Simulink in MATLAB also have been generated the subsystems for each equations.

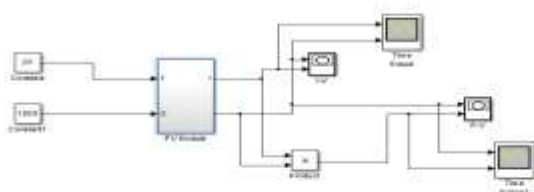

Fig.3 Overview design of a PV module using Simulink/MATLAB

Fig.3 is the overview model of a photovoltaic module which has been designed in Simulink/MATLAB. Its output power has been calculated (table 2) and I-V and P-V characteristics graph (Fig.5&6) also has been drawn.

3. EQUIVALENT CIRCUIT OF A PHOTOVOLTAIC CELL

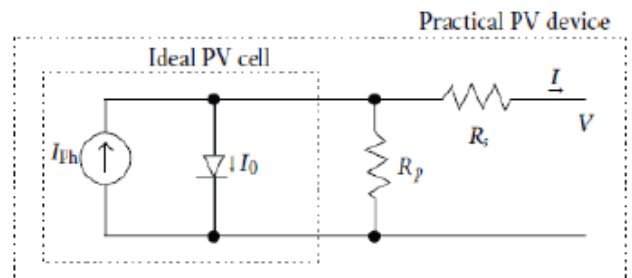

Fig.4 Circuit of a basic PV cell

The Fig.4 shows the equivalent circuit of a photovoltaic cell which consists of a diode, resistance and photovoltaic current which is being obtained from irradiation [4].

Table 1: Design Parameters used for PV Module

Name	Value
E_G	1.1000
T	298
k	1.3800e-23
n_s	54
R_s	0.2210
R_{sh}	415.4050
I_{sc}	8.21 A
V_{oc}	32.9 V
K_v	0.0032
n	1.3000
q	1.6000e-19

Where,

E_G is energy band gap

T represents the temperature

k is Boltzmann's constant

n_s is the number of cells

R_s is series current

R_{sh} is shunt current

I_{sc} is short circuit current

V_{oc} is open circuit voltage

K_v is temperature coefficient

n represents the ideality factor of the diode

q is the charge.

Table 2: Power of a PV module without using maximum power point tracker and DC-DC boost converter

Irradiance (W/m ²)	Temperature (°C)	Voltage (Volts)	Current (Amps)	Power (Watts)
1000	25	32.48	0.8831	28.70
700	25	31.73	0.8834	28.03
500	25	30.98	0.8806	27.28

Table 2 shows the calculated power which is 28.7 watts of a photovoltaic module at the irradiation of 1000 W/m² similarly 28.03 watts at the irradiation of 700 W/m² and 27.28 watts at the irradiation of 500 W/m² without using any controller and converter.

The I-V and the P-V characteristics of a photovoltaic module with the irradiation of 1000 w/m² and a constant temperature of 25 °C have shown below:

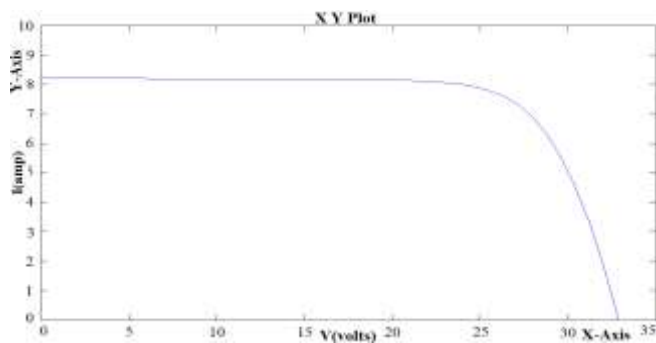

Fig.5 I-V characteristics graph of a PV module

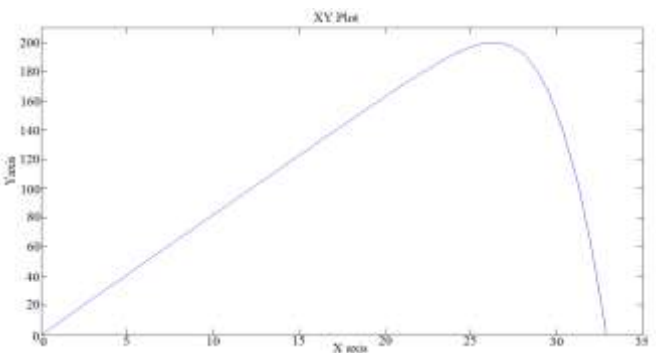

Fig.6 P-V characteristics graph of a PV module

4. ALGORITHM OF INCREMENTAL CONDUCTANCE MPPT

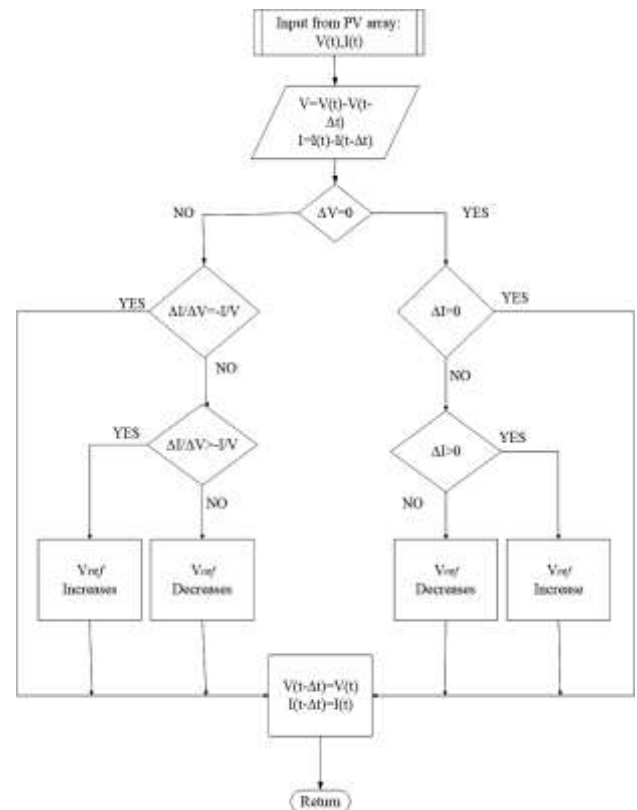

Fig.7 Flowchart of Incremental conductance MPPT

Incremental conductance can be defined by differentiating the photovoltaic power with respect to the voltage at the same time setting the result at zero for the maximum peak power [4 & 7].

The following equations explain the operation of MPPT in a better way:

$$\frac{dP}{dV} = 0, \text{ at MPP}$$

$$\frac{dP}{dV} > 0, \text{ left of MPP}$$

$$\frac{dP}{dV} < 0, \text{ right of MPP}$$

5. CONVERTER

This paper, the used converter is a DC-DC boost converter which helps to increase the voltage and decrease the current at the same time. After designing of a photovoltaic module when it gets connected to MPPT for maximizing the power at the same it's also becomes important to use a proper converter.

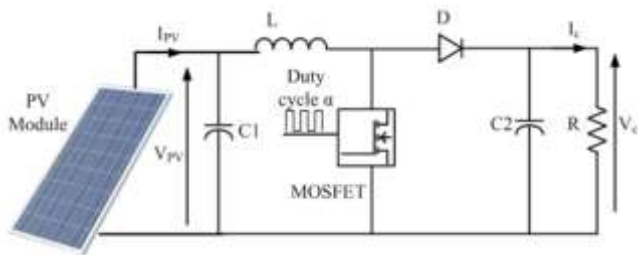

Fig.8 Basic structure of boost converter

The DC-DC boost converter must consist of at least two semiconductor devices like MOSFET and Diode (Fig.8) and at least one element which can store energy like a resistor or capacitor or both.

6. SIMULATION AND RESULT

Fig.9 shows the proper setup to design a photovoltaic module and the module has been connected to the maximum power point tracker and the converter as well. The output power has been calculated at the different irradiation by keeping the temperature constant which is 25 °C.

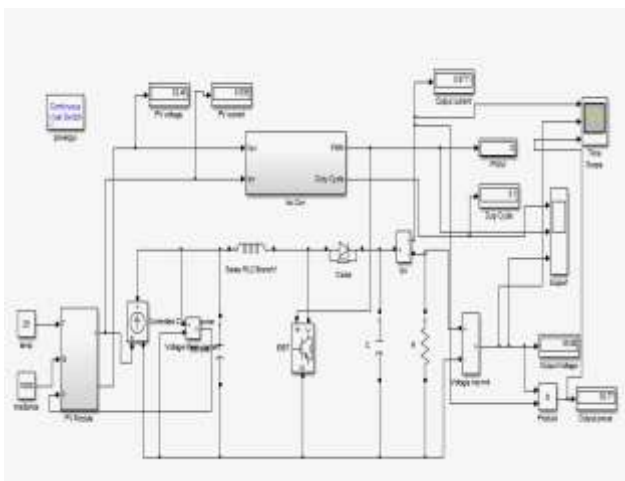

Fig.9 Experimental setup to design a PV module with Incremental Conductance & DC-DC Boost Converter

Table 3: Power of a PV module after using maximum power point tracker and converter

Irradiance (W/m ²)	Temperature (°C)	Voltage (Volts)	Current (Amps)	Power (Watts)
1000	25	35.10	0.8876	30.81
700	25	34.27	0.8568	29.30
500	25	33.44	0.8359	27.95

In table 2 the power of a photovoltaic module has been shown when the module is not connected to the MPPT and converter while in table 3 the power of a photovoltaic

module has been shown when the module is connected to the MPPT and converter. After analyzing table 2 and table 3 it is clear that the improved power is being achieved.

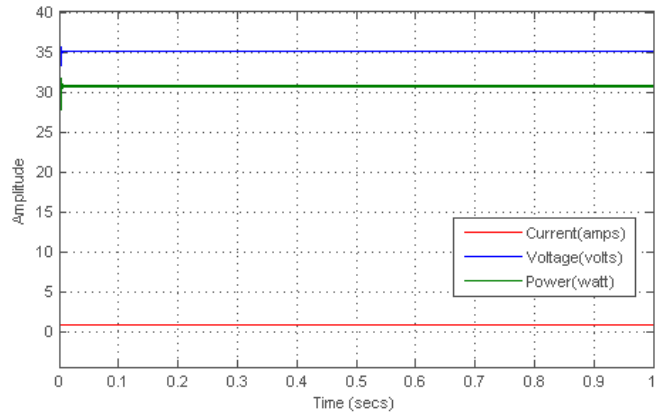

Fig.10 Power of photovoltaic module at irradiance of 1000 Watt/m².

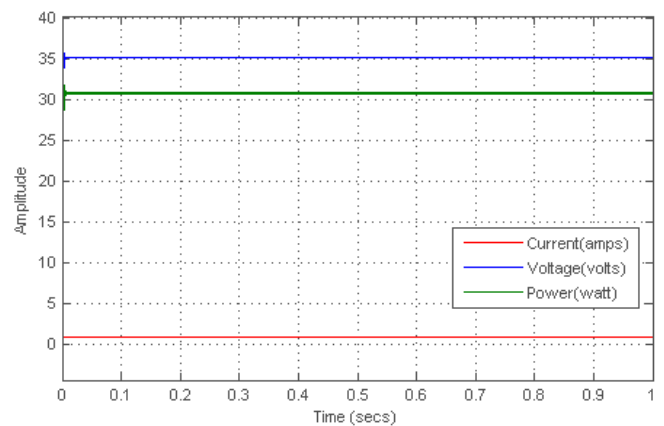

Fig.11 Power of photovoltaic module at irradiance of 700 Watt/m².

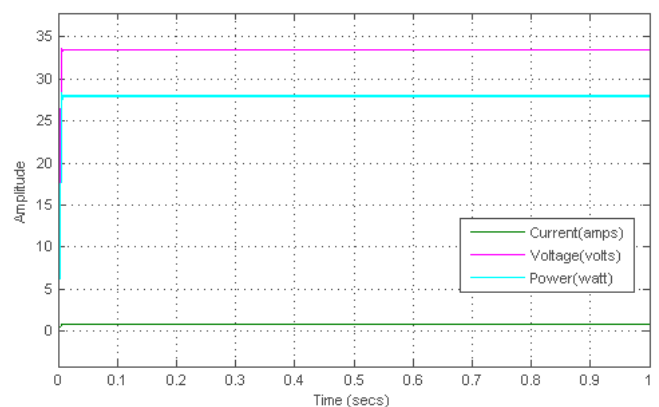

Fig.12 Power of photovoltaic module at irradiance of 500 Watt/m²

7. CONCLUSIONS

In this paper a photovoltaic module, a maximum power point tracker (incremental conductance MPPT) and a converter (DC-DC boost converter) has been designed. The power of the photovoltaic module has been calculated without connecting the MPPT and converter and that is 28.7 watts at the irradiation of 1000 W/m², 28.0 watts at irradiation of 700 W/m² and 27.28 watts at the irradiation of 500 W/m². After that the module has been connected to MPPT and converter then the improved power has calculated and that is 30.8 watts at the irradiation of 1000 W/m², 29.3 watts at irradiation of 700 W/m² and 27.95 watts at the irradiation of 500 W/m² which shows the improvement in power of photovoltaic module and its has been shown in Fig.10, 11 and 12. All the simulation process was done using SIMULINK/MATLAB.

REFERENCES

- [1] Hossain, M., Rahim, N., & Selvaraja, J. (2016). Comparative Performance Analysis of Maximum Power Point Tracking Technique for Large Scale Photovoltaic System. *4th IET Clean Energy and Technology Conference (CEAT 2016)*. doi:10.1049/cp.2016.1305.
- [2] Safari, A., & Mekhilef, S. (2011). Simulation and Hardware Implementation of Incremental Conductance MPPT With Direct Control Method Using Cuk Converter. *IEEE Transactions on Industrial Electronics*, 58(4), 1154-1161. doi:10.1109/tie.2010.2048834.
- [3] Kechiche, O. B., Barkaoui, B., Hamza, M., & Sammouda, H. (2017). Simulation and comparison of P&O and fuzzy logic MPPT techniques at different irradiation conditions. *2017 International Conference on Green Energy Conversion Systems (GECS)*. doi:10.1109/gecs.2017.8066266.
- [4] Nademi, H., Soghomonian, Z., & Norum, L. (2017). A robust predictive MPPT strategy: An enabler for improving the photovoltaic conversion source. *2017 IEEE 6th International Conference on Renewable Energy Research and Applications (ICRERA)*. doi:10.1109/icrera.2017.8191223.
- [5] P.vital rao, Dr.K.R.Sudha, S.Prameela Devi(2013). Incremental conductance (IncCond) algorithm for maximum power operating point (MPOP) of Photo-Voltaic (PV) power generation system. *American Journal of Engineering Research (AJER)*, e-ISSN:2320-0847 p-ISSN:2320-0936.
- [6] Bimenyimana, S., Asemota, G. N., & Li, L. (2017). Maximum power point performance tracking comparison between incremental conductance with perturb and observe algorithms in photovoltaic power systems. *2017 2nd International Conference on Power and Renewable Energy (ICPRE)*. doi:10.1109/icpre.2017.8390668.
- [7] Soriano, L. A., Ponce, P., & Molina, A. (2017). Analysis of DC-DC converters for photovoltaic applications based on conventional MPPT algorithms. *2017 14th International Conference on Electrical Engineering, Computing Science and Automatic Control (CCE)*. doi:10.1109/iceee.2017.8108884.