

# Material handling system for pick and place using Image processing and PLC

Mrs. Arti Utikar<sup>1</sup>, Vinita Yerande<sup>2</sup>

Assistant Professor, Instrumentation & Control Engineering Department  
D. Y. Patil College of Engineering Akurdi, 411044, Maharashtra, India

\*\*\*

**Abstract** - In Industries, it is required that the processes to be very fast and efficient to save the time and manpower. To fulfill this need pick and place method is implemented. In this paper, Material handling system for pick and place with image processing & lab view is explained. The pick and place mechanism is existing there in industries. But as per the new era the need of automation is to get fast, efficient and easy to handle process. The paper explains the methodology to get pick and place mechanism in an innovative way. Here image processing plays a vital role. The particular Color and character can be detected through image processing. After detection of object it is picked by the moving arm having pneumatic suction. Then object is placed in the particular block with respect to color and character. The total process is observed in HMI. Also the vacant places in the block can be identified for next pick and place sequence. Labview is used for the total automation. Also the IoT application can be possible. The method has real time application.

**Key Words:** PLC, HMI, DC, IoT, CAD

## 1. INTRODUCTION

India is one of the most forward countries in developing itself in every aspect. The developing sectors are Infrastructure, Economic conditions, Digitalization, Engineering sectors, InfoTech Industry, Manufacturing field, Research and Development, Space and Military organizations, banking sectors etc. These developing fields are thus introducing a lot more opportunities along with it[1]. Highlighting the development of manufacturing and process industry in our country, innovation and automation has played a major role for bringing the respective sector to the upmost. Industrial revolution has been a major part of development thus, use of papers for data entries and records are been replaced by computers and similarly labours and human workers are been replaced by robots[2]. Replacement and modifications is the rule of nature. In manufacturing company where there is no place for error, human interventions in processes handling are been avoided to eliminate human error. So, similarly human control in manufacturing company are needed to be replaced by the technology in today's trends i.e. Automation. Automated manufacturing systems operate in the factory on the physical product[3]. They perform operations such as processing, assembly, inspection, or material handling, in some cases accomplishing more than one of these operations in the same system. They are called automated because they perform their operations with a reduced level of human

participation compared with the corresponding manual process.

### Need of pick and place of systems:

The drawbacks[5] of on-going or present systems in manufacturing plants are

- 1) Maximum human intervention. Thus, increasing the possibilities of human errors in the systems.
- 2) Manual material analysis
- 3) Manual process and its components reporting
- 4) Tracing and material handling is difficult
- 5) For quality testing only few components from the whole packaging are been supervised, hence proper testing is not done.
- 6) Error detection is not easy
- 7) Time consuming
- 8) Labour management
- 9) Investment a lot of Money and Time

These above mentioned problems are been resolved in this project.

Along with the solution for the above problems, the project has few add-on advantages like

- 1) Multiple tasks on single conveyor
- 2) Use and application of IoT
- 3) Need of less labours/supervisors
- 4) Fully automatic from sorting, testing till packaging
- 5) Automatic report generation along with uploading of the data on cloud
- 6) Power saving
- 7) Space management
- 8) Easy user interface and handling

## 2. METHODOLOGY

The material handling and sorting on basis of colour detection and on character are been done on a single system. The sorted products according to their colour and character are then packaged for the final dispatch according to the need of the customer. We have taken into consideration, the need of different requirements of the customer. The barcode scanner is used here to scan the 2D code. The 2D code will have the information about the type of requirement of the customer and the system will execute the requirement as per the need. The executed task is again checked for its accuracy

i.e. the quality checking and precision assurance of the system.

### 3. WORKING PRINCIPLE

The product is characterized into two types.

- 1) According to their character being embedded on it: Characters are A1,A2,A3,B1,B2,B3,C1,C2,C3
- 2) According to the colour: Red, Blue and Yellow

#### 1) Working of system for Character recognition:

The system working starts from the hopper, where the operator puts the products (Blocks) having predefined characters i.e. from A1 to C3 in random sequence into the hopper. After passing the block from the hopper, it is dropped onto the conveyor belt. Initially the conveyor belt is at halt and sets in motion only when it senses the block at initial location by proximity sensor. The camera is positioned at the initial location and the character embedded on the block is identified and is moved forward onto the conveyor belt. The sorting system further sorts the blocks according to their characters and are pushed down the conveyor belt. The pick and place mechanism then places the blocks to their predefined locations in storage area.

#### 2) Working of system for colour detection:

The system for this category again starts from the hopper. Where the operator puts the blocks of colours into the hopper. The colour is detected by the same camera and is then sorted according to its colour from the conveyor. This above systems sorts the material according to its characteristics i.e. character and colour and are transported by pick and place mechanism to its predefined location into the storage area.

#### 3) Working of final packaging and quality inspection system:

The previously sorted blocks are been packaged and been tested. Each vendor or customer has its unique requirement of type of blocks (Combination of colour and character blocks). Hence, to fulfill this necessity, barcode generation and scanning technique is used. Each vendor's requirement is been recorded in the 2D barcode. The requirement on the barcode is scanned by the barcode scanner, thus actuating the system to accomplish the requirement.

Take an example : The requirement of the vendor is of total 4 blocks having specification of blocks like A2+yellow+red+C1.This requirement is been scanned on scanner from the 2D code. So to execute the requirement the PLC actuates the pick and place mechanism that picks the individual sorted blocks from the storage area and places the blocks into package area[13]. The same packaging is then been evaluated for quality checking. The quality checking process includes one camera. The packed block arrangement

as per the vendor's requirement is been passed beneath the camera. The camera thus, again detects the colour and the character of the final product (Containing multiple blocks) and compares with the supplied requirement [9]. If the product matches with the requirement, the product is further dispatched and if not then an error is been generated to inform the supervisor about the error. The inventory data is been generated and saved on Excel sheets. Inventory control is the subpart of the project. The sorting, and the packaging report is been generated and been sent to the required authority. The overall system is been controlled from remote locations using IoT.

### 4. ARCHITECTURE OF THE PROJECT

The main components in the project are

- Camera
- PLC
- HMI
- Conveyor system
- Proximity sensors
- Stepper motors and driver
- DC motors and driver
- Switches and indicators
- IoT system

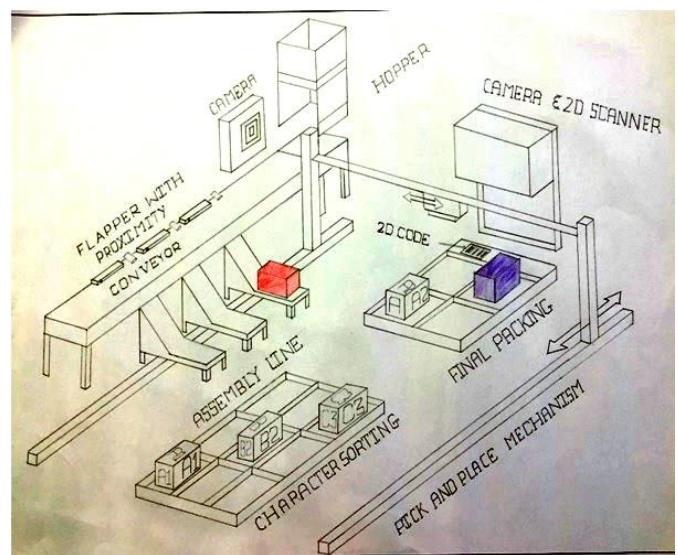

**FIG 1. SCHEMATIC VIEW OF PICK & PLACE MECHANISM**

Figure 1 indicates schematic view pick & Place mechanism. PLC is considered as the heart of the project. The main components or sensors producing output is been directly connected to input and output ports of the PLC[14]. PLC has been adopted for control of manufacturing processes, assembly line, robotics, many more industrial application. Proximity sensor and switches are the inputs to PLC. A proximity sensor senses the nearby object without touching the object. Function of PLC is to control the process. Ladder diagram, functional block diagram, instruction list, structured list are the languages of PLC[8]. Here ladder diagram is used for implementation of project. HMI view is provided through labview Here Raspberry Pi is used here as

a controller and allows us to create a platform for IoT applications. Raspberry and PLC has a communication path (RS485/422/232 communications). IoT interacts with PLC through Raspberry as a medium of communication. Mobile can be used to monitor the data which is stored directly to the cloud through Wi-Fi connection and internet protocols. The computer and mobile/tablets are used to display the inventory report of the sorting and final packaging[7]. Using IoT we can mail a copy of the report to the required respective authorities.

### 5. CONVEYOR

A conveyor system is a common piece of mechanical handling equipment that moves materials from one location to another. Conveyors are especially useful in applications involving the transportation of heavy or bulky materials. In material handling and packaging industries, Conveyor systems allow quick and efficient transportation for a wide variety of materials, which make them very popular. Its consumer applications, as they are often found in supermarkets and airports, constituting the final leg of item/bag delivery to customers. Many kinds of conveying systems are available and are used according to the various needs of different industries. There are chain conveyors (floor and overhead) as well. Chain conveyors consist of enclosed tracks, I-Beam, towline, power & free, and hand pushed, trolleys. Conveyor systems are used widespread across a range of industries due to the numerous benefits they provide. Conveyors are able to safely transport materials from one level to another, which when done by human labor would be strenuous and expensive [12].

It can be installed almost anywhere, and are much safer than using a forklift or other machine to move materials. They can move loads of all shapes, sizes and weights. Also, many have advanced safety features that help prevent accidents. There are a variety of options available for running conveying systems, including individual needs. The block diagram of architecture of the project is been given in figure no (2).

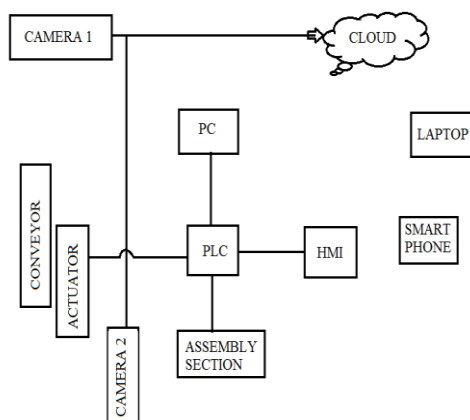

Fig 2: Architecture of Pick & Place Mechanism

### Experimental Set up of Pick & Place Mechanism

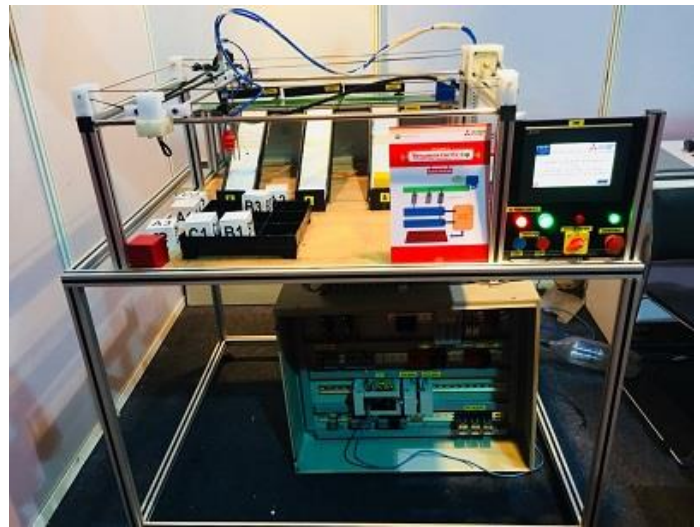

Fig: Experimental set up

### 6. CONCLUSION

Thus pick & place mechanism for material handling system using image processing & PLC is implemented. Picking of object is based on sorting done by two methods either by colour or by detecting characters. Object is passed through hopper. The barcode scanner or camera is used to scan the 2D code. Comparison of object is done by labview. After detection of object it is picked by the moving arm having pneumatic suction. Then object is placed in the particular block with respect to color and character. Thus this project can be used for successful implementation of Material handling system.

### REFERENCE

[1] RENSheng-le, LU Hua, WANG Yong-zhang, FU Hong-ya, "Development of PLC-based Tension Control System," Science direct Chinese Journal of Aeronautics, Volume 20, Issue 3, pp. 266-271, 2007

[2] WANG Hong, "Design of PLC-based Hydraulic System for Workpiece Turnover", Science direct Procedia Engineering, Volume 15, pp.122-126, 2011

[3] A. SelwinMichPriyadharsona, R. Ganesanb ,Prabhu Kumar Surarapu , "PLC – HMI Automation based Cascaded Fuzzy PID for Efficient Energy Management and Storage in Real Time Performance of a Hydro Electric Pumped Storage Power Plant", Science direct Procedia Technology, Volume 21, pp. 248 – 255, 2015

[4] Tomas Skripcak, PavolTanuska, "Toward Nonconventional Human–Machine Interfaces for Supervisory Plant Process Monitoring", IEEE transactions on human-machine systems, vol. 43, Issue no. 5, pp. 437-450, 2013

[5] Khin Moe Myint, Zaw Min MinHtun, HlaMyoTun, "Position Control Method For Pick And Place Robot Arm For Object Sorting System", International journal of scientific & technology research, Vol. 5, issue 06, pp. 57-61, 2016

[6] S.PujaDhepekar, Prof.Yashwant G. Adhav, "Wireless Robotic Hand for Remote Operations using Flex Sensor", International Conference on Automatic Control and Dynamic Optimization Techniques (ICACDOT) International Institute of Information Technology (I<sup>2</sup>IT), Pune, pp. 115-118, 2016

[7] Ayob, M., and G. Kendall, 2004. A nozzle selection heuristic to optimise the hybrid pick and place machine, IEEE Conference on Cybernetics and Intelligent Systems, 2: 1260-1265. Brian Rooks, 2001. Manufacturing week targets assembly and vision, Assembly Automation, 21(2): 117- 122.

[8] Briot, S. and I.A. Bonev, 2010. Pantopteron-4: A new 3T1R decoupled parallel manipulator for pick-andplace applications, Mechanism and Machine Theory, 45: 707-721.

[9] Goede, P., P. Verstegen and J.V. Gastel, 2007. Design of a shuttle used in an innovative pick and place machine concept, IEEE International Symposium on Assembly and Manufacturing, pp: 135-140.

[10] Mr. Modi Akshaykumar Mahendrakumar, Prof. Pravinkumar D. Patel, "DESIGN AND DEVELOPMENT OF PICK AND PLACE ROBOTICS ARM USING PLC-SCADA" 1 st International Conference on Current Research in Engineering (SIEICON-2017) April 13, 2017

[11] Dipak Aphale 1, Vikas Kusekar, "PLC Based Pick and Place Robot with 4 DOF" IJRSET, Vol. 5, Issue 2, February 2016

[12] Radha Kausale and Vinita Yerande, "INSPECTION AND STORAGE OF PRODUCT USING PLC" International Journal of Modern Trends in Engineering and Research (IJMTER) Volume 04, Issue 5, [May- 2017]

[13] Kelvin Scott, "programmable logic control programming"

[14] Garry denning, "introduction to programmable logic controllers ISBN-139781401884260, Dec 2005"



Ms. Vinita V. Yerande  
Assistant Professor,  
Instrumentation & Control,  
D. Y. Patil College of engineering  
Akurdi, Pune 411044

## BIOGRAPHIES



Mrs. Arti Ajay Utikar  
Assistant Professor,  
Instrumentation & Control,  
D. Y. Patil College of engineering  
Akurdi, Pune 411044