

INTRODUCTION AND DESIGN OF CONICAL TYPE DRAFT TUBE

SHELKE KRUSHNA¹, PATIL MIT², WARKE NILESH³, AVINASH JEJURKAR⁴

^{1,2,3}BE Scholar, Department of mechanical engineering, PRE'S, S.V.I.T. Nasik, MH, INDIA

⁴ME Scholar, Department of mechanical engineering (Design), PRE'S, S.V.I.T. Nasik, MH, INDIA

Abstract - Day by day hydraulic power plants are goes on increasing. So it is necessary that we should be focus or concentrate on design of turbine parameters. Basically there are so many types of water turbines are present in everywhere. For example pelton wheel water turbine, Francis water turbine, tidal, Kaplan water turbine. In the reaction turbine draft tube is necessary part of turbine. Because of it permits the negative head to establish at outlet of runner, hence it increases the net head available to turbine. Also it converts kinetic energy of water at exit of runner into pressure energy so that useful head at runner exit is increased. utilization of kinetic energy at exit of runner increase the power output and efficiency of the turbine. Apart from this, the location of turbine level close to tail race level could cause the flooding of turbine during rainy season. That's why it is necessary to design and analyze draft tube. In this paper we are going to focus on importance and design of draft tube.

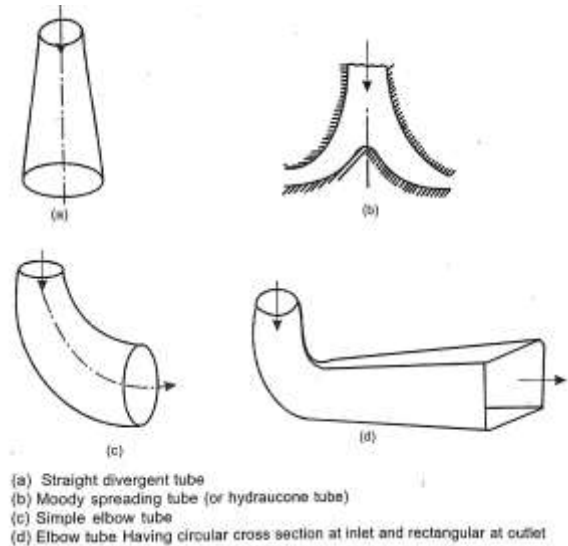

Fig no.(1) Different types of draft tube

Key Words- Hydraulic power, Kaplan turbine, draft tube, tail race, runner.

1. INTRODUCTION

The water is passing through runner to tail race through the draft tube. Draft tube is pipe type or passage of gradually increasing cross sectional area which connects runner exit to tail race. The material of draft tube cast or plain steel or may be concrete. Draft tube has two purposes i) It permits suction head at a runner exit. ii) It converts velocity energy into pressure energy at the exit.

1.1 Types of draft tube:

- Conical type draft tube
- Moody spreading tube
- Simple elbow tube
- Elbow tube have circular c/s at inlet & rectangular at outlet

1.1.1 Conical type draft tube:

Taper angle of divergent portion of tube is great importance. If taper angle, 2θ is large it will be cause separation of flow from wall of draft tube. In case taper angle is small, length of draft tube needed long. Angle θ is always less than or equal to 10° . This type of draft has more efficiency, which is 90%.

1.1.2 Moody spreading tube:

It is similar to conical draft tube which is shown in above fig(b). It is provided with a solid central core which reduces the whirling action of water. It has efficiency up to 85% and it is used for vertical shaft turbine having large whirl component at exit of their runner.

1.1.3 Simple elbow tube:

It is circular cross section throughout from inlet to outlet shown in above fig(c). Which is turned through 90° . This draft tube is used in Kaplan turbine. These tubes reduce depth and cost of system. It is made of concrete and having efficiency up to 60%.

1.1.4 Elbow tube has circular c/s at inlet & rectangular at outlet:

it is circular in cross section at inlet and rectangular at exit of draft tube. Horizontal portion of tube is gradually inclined upwards so that water leaves the tube almost at tail race level. In this case cost and depth is also reduced. The efficiency of these draft tube in the range of 60 % to 80 %. It is also made with concrete.

2. DESIGN OF CONICAL DRAFT TUBE:-

In this paper we are focusing on conical draft tube, as name suggest shape of conical is conical that is increasing cross section from top to bottom. Taper angle of divergent portion of tube is great importance. If taper angle, 2θ is large it will be cause separation of flow from wall of draft tube. In case taper angle is small, length of draft tube needed long. Angle θ is always less than or equal to 10° [1]. This type of draft has more efficiency, that is 90%[1]

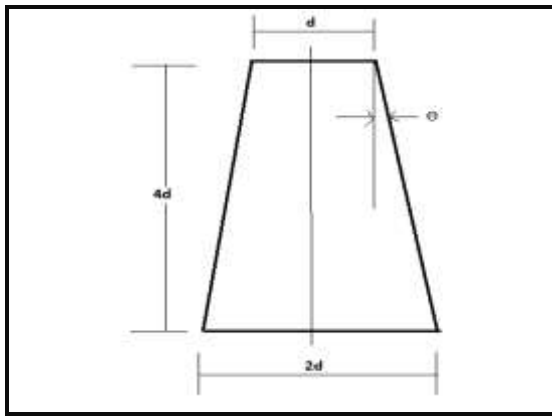

Conical draft tube Fig no. (2)

Height of draft tube is normally,

$$H = 4 * d$$

From fig points 1, 2 & 3 have been consider at runner entry, exit and at outlet end of draft tube respectively. By applying Bernoulli's equation between point 1 and 2 .

$$(P_2/W) + (V_2^2/2 * g) + Z_2 = (P_3/W) + (V_3^2/2 * g) + Z_3 + h_f$$

But as we know,

$$(P_3/W) = (P_A/W) + h$$

$$Z_2 - Z_3 - h = H_s$$

$$(P_2/W) = (P_A/W) - [H_s + (V_2^2 - V_3^2)/2 * g] + h_f$$

Efficiency of draft tube,

$$\eta_d = [(V_2^2 - V_3^2)/2 * g] - h_f$$

3. CONCLUSION

Draft tube is necessary part of Kaplan turbine.so there are so many type of draft tube. But conical type of draft is the best. Because, it gives higher efficiency about 90 % and also construction % design is very simple.

REFERENCES

1. Shubham M. Harde, Shubham Thakare, Shubham A. Shende, Swapnil Pardhikar, Prof. Shailendra Daf, "Effect of Draft tube on Hydraulic turbine", volume 1, ISSUE 4, ISSN : 2455-2631, April 2016.
2. Lekha Mourya, Rahul Mishra, Swapnil Jain, "Analysis on hydraulics performance of Kaplan turbine based on elbow draft tube geometry", volume 05, ISSUE 6, ISSN: - 2321-9653, JUNE 2017.
3. Sumeet J. Wadibhasme, Shubham Peshne, Pravin Barapatre, Santosh Barade, Saurabh Dangore, Shubham Harde, Prof. Shailendra Daf., "Hydraulic turbine draft tube : literature review", volume 5, ISSUE 5, ISSN :- 2278-7798, March 2016.
4. Vikas Rai, Nishant Vibhav saxena, "A Review on advance in the design and analysis of draft tube for reaction turbines", volume 5, issue 5, e-ISSN : 2395-0056, p-ISSN : 2395-0072, May 2018.
5. D.S. Kumar, ' Fluid mechanics and fluid power engineering'.
6. P.N. Modi and S.M. Seth, 'Hydraulic and fluid mechanics including Hydraulic machines'.

BIOGRAPHIES



SHELKE KRUSHNA VISHWAS, BE, MECHANICAL ENGINEERING, PRE'S,SVIT,NASIK,MH,INDIA



"PATIL MIT PRAKASH, BE, MECHANICAL ENGINEERING, PRE'S,SVIT,NASIK,MH,INDIA "



"WARKE NILESH LATESH, BE, MECHANICAL ENGINEERING, PRE'S,SVIT,NASIK,MH,INDIA "