

ACCIDENT DETECTION AND ALERTING SYSTEM

P.G. KATE¹, S.T. SHINDE², S.V. JAGTAP³, S.T. KAMBLE⁴

^{1,2,3}BE Student, Electronics and Telecommunication, SND COE & RC, Yeola, Maharashtra, India

⁴Asst. Prof., Electronics and Telecommunication, SND COE & RC, Yeola, Maharashtra, India

Abstract - Transportation is a basic need of society. It's make human life more easy and comfortable. As far as increasing transportation, accident is also increasing. It cause death of human and damages any part of body. To prevent the particular action, we try to implement a system is Accident detection and messaging system using GPS and GSM. In this system, the vibration sensor is used as an input to the system and corresponding response is analyzing by the Arduino. If accident occurs, sensors reading exceed the threshold and it takes the appropriate action. The SMS is send to the authorities and provide the immediate help to the people who met in an accident. The proposed embedded approach provides the promising result.

KEYWORDS: Arduino Processor, GSM Module, GPS Module, Accelerometer sensor, LCD Display, Smart phone.

1. INTRODUCTION

The development of a transportation system has been the generative power for human beings to Have the highest civilization above creatures in the earth. Automobile has a great importance in our daily life. We utilize it to go to our work place, keep in touch with our friends and family, and deliver our goods. But it can also bring disaster to us and even can kill us through accidents. Speed is one of the most important and basic risk factors in driving. It not only affects the severity of a crash, but also increases risk of being involved in a crash. Despite many efforts taken by different governmental and non-governmental organizations all around the world by various programs to aware against careless driving, yet accidents are taking place every now and then. However, many lives could have been saved if the emergency service could get the crash information in time. As such, efficient automatic accident detection with an automatic notification to the emergency service with the accident location is a prime need to save the precious human life.

METHODOLOGY

The block diagram and circuit diagram for that system is as follow

2.1 BLOCK-DIAGRAM



Fig.1: Block diagram of Accident detection and alerting system

In this project, Arduino is used for controlling whole the process with a GPS Receiver and GSM module. GPS Receiver is used for detecting coordinates of the vehicle, GSM module is used for sending the alert SMS with the coordinates and the link to Google Map. Accelerometer namely ADXL335 is used for detecting accident or sudden change in any axis. And an optional 16x2 LCD is also used for displaying status messages or coordinates. We have used GPS Module SIM28ML and GSM Module SIM900A.

2.1.1 Microcontroller

Micro controller Based Circuitry is the BRAIN in our system. The microcontroller we have implied here is atmega16. The ATmega328 is a low power CMOS 8-bit microcontroller based on the AVR enhanced RISC architecture. AVR is modified Harvard architecture 8 bit RISC single chip microcontroller which was developed by Atmel in 1996. ATmega328 is high performance low power Atmel AVR 8 bit microcontroller. The controlling unit of the system consists of a microcontroller ATmega328. This microcontroller is used to control the system as per the output of the software of the designed system. This microcontroller receives data from the computer and accordingly allows or denies the access of the vehicle.

2.1.2 GSM module

Global System for Mobile communication (GSM) is a wireless modem that works with a GSM wireless network for mobile communication. GSM module in our proposed system is used for establishing the communication between the vehicle and the us The system consists of a GSM modem which is used to send alert message to the owner's vehicle in case of accident or collision happened in case of the vehicle. This GSM modem is interfaced with the microcontroller as shown in the architecture of the system.

2.1.3 GPS Receiver:

The Global Positioning System (GPS) is a space-based satellite route framework that gives area and time data in all climate conditions, anyplace on or close to the Earth where there is an unhampered observable pathway to four or more GPS satellites. In this system we have interfaced a GPS receiver to obtain the exact location of the vehicle for the owner's information. This GPS receiver is interfaced with the microcontroller and provides the longitude and latitude coordinates to the microcontroller.

2.1.4 Accelerometer Sensor:

An accelerometer is an electromechanical device that will measure acceleration forces. These forces may be static, like the constant force of gravity pulling at your feet, or they could be dynamic - caused by moving or vibrating the accelerometer. An accelerometer can help your project understand its surroundings better. Is it driving uphill? Is it going to fall over when it takes another step? Is it flying horizontally or is it dive bombing your professor? A good programmer can write code to answer all of these questions using the data provided by an accelerometer. An accelerometer can help analyze problems in a car engine using vibration testing, or you could even use one to make a musical instrument.

2.1.5 LCD:

This is a 16x2 LCD display interfaced with the microcontroller for the above mentioned function

2.2 CIRCUIT DIAGRAM:

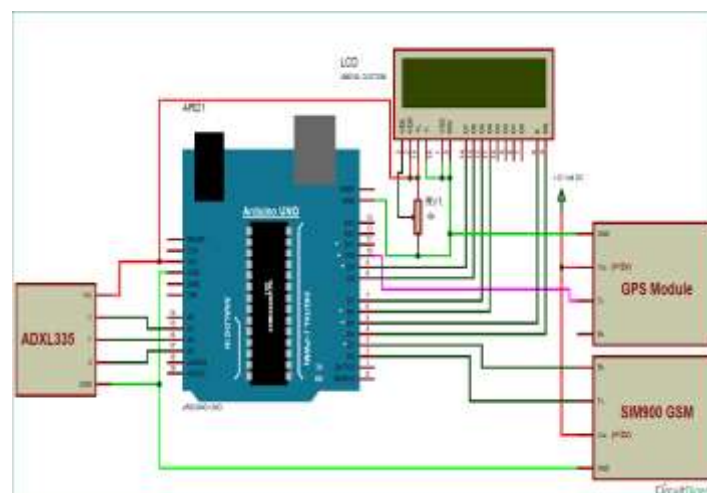

Fig. 2: Circuit diagram of Accident Detection and Alerting System

Circuit Connections of this Vehicle Accident Alert System Project is simple. Here Tx pin of GPS module is directly connected to digital pin number 10 of Arduino. By using Software Serial Library here, we have allowed serial communication on pin 10 and 11, and made them Rx and Tx respectively and left the Rx pin of GPS Module open. By default Pin 0 and 1 of Arduino are used

for serial communication but by using the Software Serial library, we can allow serial communication on other digital pins of the Arduino. 12 Volt supply is used to power the GPS Module.

GSM module's Tx and Rx pins are directly connected to pin D2 and D3 of Arduino. For GSM interfacing, here we have also used software serial library. GSM module is also powered by 12v supply. An optional LCD's data pins D4, D5, D6, and D7 are connected to pin number 6, 7, 8, and 9 of Arduino. Command pin RS and EN of LCD are connected with pin number 4 and 5 of Arduino and RW pin is directly connected with ground. A Potentiometer is also used for setting contrast or brightness of LCD.

An Accelerometer is added in this system for detecting an accident and its x,y, and z-axis ADC output pins are directly connected to Arduino ADC pin A1, A2, and A3.

When we are ready with our hardware after programming, we can install it in our vehicle and power it up. Now whenever there is an accident, the car gets tilt and accelerometer changes his axis values. These values read by Arduino and checks if any change occurs in any axis. If any change occurs then Arduino reads coordinates by extracting \$GPGGA String from GPS module data (GPS working explained above) and send SMS to the predefined number to the police or ambulance or family member with the location coordinates of accident place. The message also contains a Google Map link to the accident location, so that location can be easily tracked. When we receive the message then we only need to click the link and we will redirect to the Google map and then we can see the exact location of the vehicle. Speed of Vehicle, in knots (1.852 KPH), is also sent in the SMS and displayed on the LCD panel.

ACKNOWLEDGEMENT

We feel great pleasure to present the Dissertation entitled "**ACCIDENT DETECTION AND ALERTING SYSTEM**".

But it would be unfair on our part if we do not acknowledge efforts of some of the people without the support of whom, this dissertation work would not have been a success.

First and for most we are very much thankful to our respected Guide **Prof. Kambale S.T.** for his leading guidance in this dissertation work. Also he has been persistent source of inspiration to us. We would like to express our sincere thanks and appreciation to **Prof. Patil S.T.** (HOD) for valuable support. Most importantly we would like to express our sincere gratitude towards our **Friends & Family** for always being there when we needed them most

REFERENCES

- 1.Rohit Ganiga, Rohit Maurya, Archana Nanade,"Accident detection system using Piezo Disk Sensor", International Journal of science, Engineering and Technology Research(IJSETR) volume6,Issue3,March 2017,ISSN 2278-7798
- 2.J.Whipple,W.Arensman,M.S.Boler,"public safety application of GPS enabled smart phones and the android operation system", IEEE Int. conf. on system, man and cybernetics:2009
- 3.Hemjit Sawant, Jindong Tan, Qingyan Yang Qizhi Wang," Using Bluetooth and Sensor networks for intelligent transport systems", In proceeding of Intelligent Transport System; 2004
- 4.Helia Mamdouhi, Sabira Khatun, Javed Zarrin," Bluetooth Wireless monitoring, Manging and Control for inter vehicle in vehicular adhoc networks", Journal of computer Science, Science Publication;2009
- 5.Jules White, Brian Dougherty, Adam Albright, Douglas C," Using Smartphone to Detect Car Accidents and Provide Situational awareness to emergency responders chirs Thompson", Mobile Wireless Middleware, Operating system and Application;2010

BIOGRAPHIES



Pramod Gorakh Kate,

Department of Electronics and
Telecommunication Engineering,
SND COE Yeola, Pune University



Sandeep Tukaram Shinde,

Department of Electronics and
Telecommunication Engineering,
SND COE Yeola, Pune University



Sandip Vasant Jagtap ,

Department of Electronics and
Telecommunication Engineering,
SND COE Yeola, Pune University



Prof. Sanghamitra Tatyrao
kamble,
Department of Electronics and
Telecommunication Engineering.
SND COE Yeola, Pune University,