

Web based Solution for Smart Home Functionality Extension and Control, using Artificial Intelligence & Raspberry Pi: A Review

Ms. Sima. M. Shinde¹, Mr. Desai P.B²

¹Student, E&TC Dept. of AMGOI Engineering, Maharashtra, India

²Professor, E&TC Dept. of AMGOI Engineering, Maharashtra, India

Abstract - The general style of Home Automation System (HAS) implements low price wireless communication between a Raspberry Pi module and google assistant. This paper provides a mixture of those 2 components--security and simple fashion for individuals. This paper is intended to help and supply support for all demographic. It introduces a wise home idea that improves the quality of living reception. The paper is meant to regulate electrical appliances associate degree in a very home or workplace victimisation an Raspberry Pi. The most system implements wireless technology to supply remote access from raspberry pi. The paper principally focuses on the observance and management of good home remotely and providing security, once the user is removed from home. The paper is meant to regulate electrical appliances and devices within the house with comparatively low price style, easy interface and simple installation. This paper differentiates itself from others because it has its own computer code level application to regulate the house appliances..

Keywords —: Home Automation, Intelligence, Sensor System, Raspberry Pi, voice command

1. INTRODUCTION

Today the technological worlds modify principle is to automatize every conceivable issue for simplicity in life, providing security, saving electricity and time. In this home automation is one amongst the previous things to mechanically on and off the house appliances. Home automation may be characterised as a technique for doing one thing while not human inclusion. It should incorporate brought along to manage of lighting, machines, heating, ventilation, air-conditioning, and security door lockup and completely different systems, to supply improved convenience, comfort, energy potency and security. The concept of automating every appliance within the house is done from a few years past, it started with connecting 2 electrical wires to the battery and shut the circuit by connecting wires to the battery and close the circuit by connecting load as a light-weight. Later it is developed by totally different organizations, that creates its own automation systems with totally different devices like sensors, controllers, actuators, buses, and interfaces. In gift days most of the automation systems utilize the mixture of hardwired and wireless systems for dominant the appliances. It ought to have each instrumentality and programming got wind of for skillful systems. The recognition of home automation has been increasing

implausibly thanks to a lot of higher reasonableness and ease through Smartphones and wireless networks. Web of Things is interlinked through these networks; thanks to the recognition of the house automation is improved by the standard of service provided by the devices. Totally different home automation systems square measure developed by different authors for mechanically on and off the appliances with different applications.

The popularity of good home automation technologies is growing, and special attention is given to the voice management in good home environments. Till recently, the offered solutions for good home automation provided user interfaces as mobile and internet applications. However, varied voice recognition technologies area unit already offered, which may be totally integrated with the embedded systems. Recently, a number of the makers started providing devices hopped-up by the prevailing voice recognition services. Most of those makers additionally offer genus Apis which will be accustomed integrate applications or entire devices with the web voice recognition service.

In this paper, we have a tendency to explore the likelihood of adding voice management to the prevailing good home automation (HA) system. The hour angle system consists of the varied finish devices, that area unit controlled by the central entry unit. to boot, cloud services area unit provided to change remote of the hour angle system. we would like to create the system within which voice commands is accustomed management an oversized variety of devices like lights, plugs, sensors, dimmers, ventilation, security, etc. Our goal is to spot the voice recognition tools which will be used for this purpose, and to gauge the doable bailiwick approaches[1].

2. ARCHITECTURE OF THE VOICE ENABLED HA SYSTEM

So as to modify voice management in HA systems, we will either use the prevailing on-line voice recognition engines, or specialize in those which will be used offline. Betting on the chosen voice recognition technology, we tend to style the system design.

The design of a voice enabled good HA system supported cloud voice recognition is conferred in Fig. 1. The voice capturing device records the command, and sends it to the cloud service for process. Supported the recognized text, the cloud service communicates with the HA cloud,

communicating to trigger the specified action. One among the most important disadvantages of this design is that the would like for the user to be on-line to manage the devices. Also, the device communicating with the voice recognition cloud is sometimes factory-made by the service supplier, and should be noninheritable one by one.

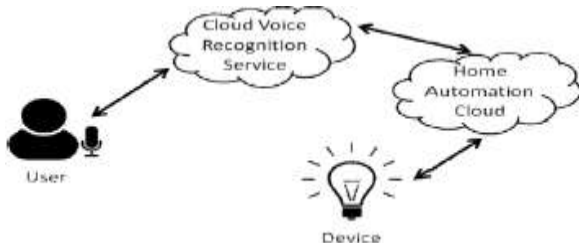

Figure 1 Architecture of voice enabled HA system based on cloud voice recognition service and third party recording devices

The other variation of the design exploitation cloud voice recognition is delineate in Figure a pair of. during this case, the ha entree records the user message, sends it to the cloud voice recognition service exploitation the provided API, so processes the results. All of the message process is completed by the entree.[1]

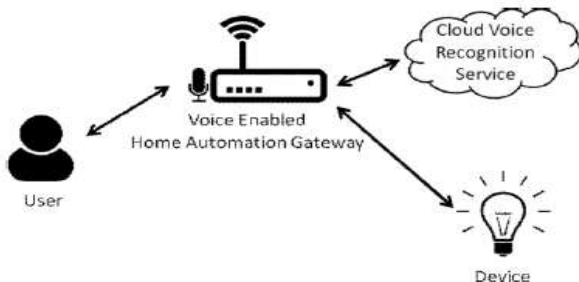

Figure 2 Architecture of voice enabled HA system based on cloud voice recognition service and gateway as the voice recorder

Finally, if offline voice recognition tools ar used, the house automation entree is totally enabled to method the voice commands, and react to them. The design of the system during this case is painted in Figure three. This approach provides the complete autonomy of the system, that doesn't got to be connected to the web so as for voice commands to perform properly. However, real-time operation of human speech could be a tight task, needs important process power, and will increase the value of the entr ee cost. .

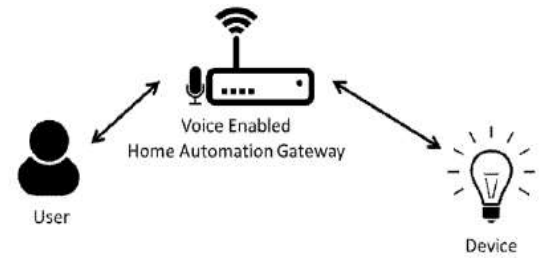

Figure 3 Architecture of voice enabled HA system with the fully voice enabled gateway

3. VOICE RECOGNITION TECHNOLOGIES OVERVIEW

In this section, we are going to compare many out there voice recognition engines and frameworks , and analyze the chances of exploitation them in one in every of the antecedently projected architectures. a number of the foremost vital characteristics of the prevailing voice recognition engines square measure bestowed in Table I.

3.1. Jasper platform

Jasper is that the open supply platform, that depends on CMUSphinx for voice recognition. However, jasper doesn't offer C or C++ API, that complicates its integration with the prevailing ha entrance. Also, it represents the interface towards the third party voice recognition engine. For the event of a custom resolution, it would be higher to use this engine directly, rather than counting on opaque gem. However, the most downside of exploitation the offline voice recognition tools lies within the necessity to dedicate important process power to the time period voice process on the entrance device.

3.2. Google Speech API

Google Cloud Speech API is accustomed connect with the net service, that provides conversion of audio to text. the benefits of exploitation this speech API ar its vast information, multi-language support (it supports over eighty languages), and also the risk of simply group action with the embedded devices. The disadvantages ar the worth, and also the restricted range of requests per day. Also, as this can be the net voice recognition service, exploitation it needs net affiliation..

3.3 Alexa Voice Service

Alexa voice service is that the heart of Alexa, an intelligent personal assistant powering Amazon Echo. Alexa voice services offer the API which will be accustomed modify Alexa assistant on the device. However, the service doesn't offer discretionary text as output. Rather, it triggers the HA practicality, that should be enforced because the cloud service. Similar as, this service isn't free. Also, the net affiliation is needed, for the system to figure properly.

3.4. Bing Speech API

Bing speech API additionally provides on-line speech to text conversion. Though the service is well integrated with numerous platforms by the remainder API, our experiments have shown that the error rate is higher for this engine, then for. Also, the amount of supported languages is considerably smaller.

Table I sums up many vital characteristics of voice recognition engines. The big variety of languages supported by, also because the risk to integrate it with each HA cloud and HA entryway, recommend that the longer term effort ought to be created to integrate this voice recognition engine into our HA solution[1]

TABLE I. Characteristics of the available voice recognition engines

Voice recognition engine	Jasper	Google Speech API	Alexa Voice Services	Bing Speech API
Open Source	✓	✗	✗	✗
Programming languages	Python	C++, JavaScript, Python and Java	Java, Python, C#, Node.js	C#
Supported languages	English	80+ languages	English and German	8 languages
Working mode	Offline	Online	Online	Online
Supported architectures	Fig. 3	Fig. 1, Fig. 2	Fig. 1	Fig. 1, Fig. 2

4. SYSTEM ARCHITECTURE

In this section, we have a tendency to discuss the attainable architectures that integrate HA system with cloud primarily based voice recognition services (VRS). Looking on the API outlined by the service supplier, we will distinguish between 2 basic ideas, that we have a tendency to describe within the text that follows.[2]

4.1. Voice Recognition Service with Textual Response

In the 1st case, the VRS API expects the recorded voice command because the input, and returns matter knowledge because the output of the voice recognition engine. During

this case, the HA voice command process application may be designed, as portrayed in Fig. 1

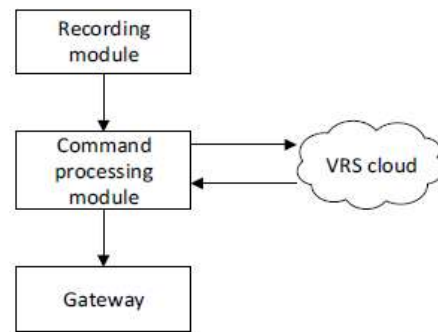

Fig. 1. Voice command processing application using VRS with textual response

The voice process application records user command, and sends it to the cloud VRS, mistreatment the provided API. Once it receives the JSON response containing matter results of the voice recognition, the HA voice process application builds the MQTT command, and sends it to the HA entree. During this case, the voice process application will either run on the dedicated HA device, or within the HA cloud, as bestowed in Fig. 2 and Fig. three severally.

4.2. Voice Recognition Service with Active Response

Instead of returning the recognized text because the result, a number of the voice recognition services offer mechanisms to outline speech patterns that trigger specific actions within the targeted ha system. This approach needs building the HA cloud endpoints which will answer the required commands. The VRS cloud performs each speech recognition and command pattern process. Supported the detected command pattern, it triggers preconfigured HA cloud endpoints victimization JSON directives. HA cloud processes these directives, and builds the acceptable MQTT commands, that are sent to the HA entranceway. The design of the HA system during this case is bestowed within the Fig.4.

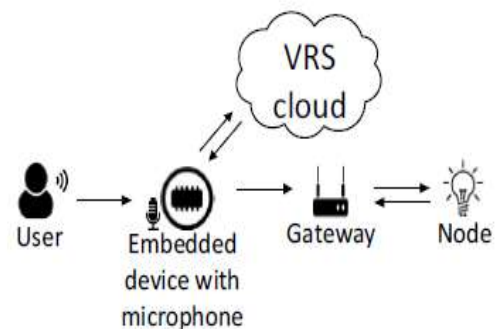

Fig. 2. Voice command processing module on the embedded device

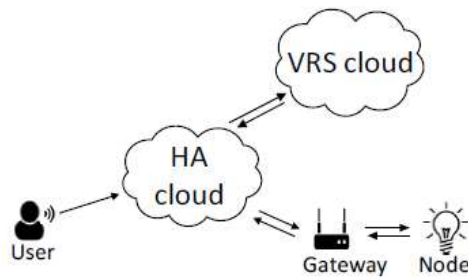

Fig. 3. Voice command processing module in the HA cloud

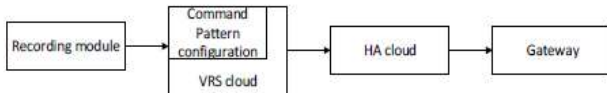

Fig. 4. Architecture of the system using VRS with active response

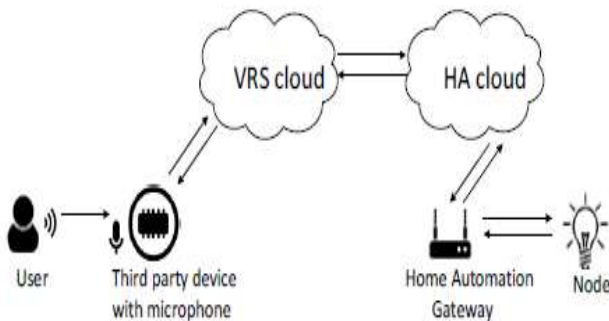

Fig. 5. Voice enabled HA system using third party recording device and VRS with active response

In this case, the voice recording is performed by the embedded device, that uses the VRS API to speak with the VRS cloud. The voice recording device will be developed from scratch, or third party will be used – Fig.5.[2]

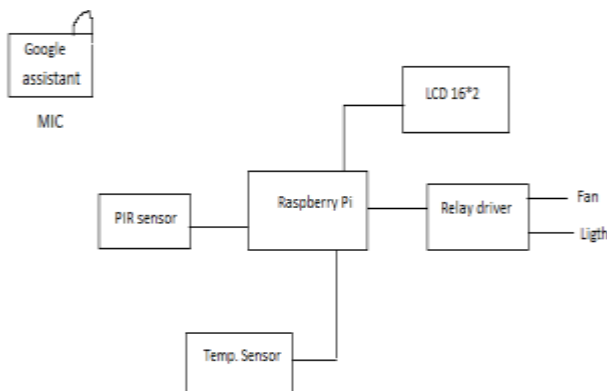

Fig.6. Architecture of the HA Using Artificial Intelligence & Raspberry pi

This fig 6 architecture presents the development of a smart home using Google assistant. The idea behind this is to control home devices with voice. On the market there are many devices available to do that. But making your own is awesome. Build your personal assistant that will do the work for you. Just your assistant requires voice commands. In this project single board computer i.e. Raspberry pi 3 is used which includes creating Adafruit account then linking to IFTTT website then adding to Google Assistant for voice commands. In this home automation appliances like Bulb, cooling Fan and Motor are used which can be controlled easily using the Google assistance from the voice control. Here we will install Google assistance in the raspberry pi and Raspberry pi will be attached with a mike which takes all the voice commands through which it will automatically control the home alliances. As the user give the voice command to the mike according to that the home appliances can be switched ON/OFF accordingly.

5. CONCLUSION

In this paper, we discussed possible architectures of the HA system, which is using cloud based VRS to provide voice command interface to the end-users. In all the architectures we control the home appliances.

REFERENCES

[1] Nikola Smiljković, "Voice Control for Smart Home Automation: Evaluation of Approaches and Possible Architectures ", Proc. 2017 IEEE 7th ICCE- Berlin 2017

[2]] Milan Vidaković, " Challenges of Integrating Smart Home Automation with Cloud Based Voice Recognition Systems ", Proc. 2017 IEEE 7th ICCE- Berlin 2017

[3] Marija Antić, "Architecture of Voice Control Module for Smart Home Automation Cloud ", Proc. 2017 IEEE 7th ICCE- Berlin 2017

[4] C. Marsh, J. Holthuis, M. Curry, S. Saha, Jasper Project, 2014, [Online] Available: <https://github.com/jasperproject>

[5] P. B. Rao and S. K. Uma, "Raspberry pi home automation with wireless sensors using Smartphone's," International Journal of Computer Science and mobile computing, vol. 4, May 2015.

[6] Mrunal Dipakkumar Bhatt, "Intelligent Voice Activated Home Automation(IVA)", Proc. 2016 MSL.

[7] Kalyani Pampattiar#, Mit Lakhani#, Rinisha Marar# and Rhea Menon#, "Home Automation using Raspberry Pi controlled via an Android Application", Proc. 2017 IJCET

[8] MQTT protocol, [Online] Available: <http://mqtt.org/>

[9] B. Petelj, M. Pandurov, D. Stefanovic, I. Papp, "Web based solution for smart home functionality extension and control", Proc. of IEEE ICCE-Berlin, 2015.

[10] [RFC6749] D. Hardt, "The Oauth 2.0 Authorization Framework", October 2012