

REVIEW: DIFFERENT TECHNOLOGY FOR DISTRIBUTED POWER FLOW CONTROLLER

Aditya Raut¹, Sameer S. Raut²

¹PG Scholar, Shri Sai College of Engineering and Technology, Bhadravati

²Assistant Professor, Shri Sai College of Engineering and Technology, Bhadravati

Abstract - Electricity is one in every of the foremost vital varieties of energy that is employed in several areas like residential, commercial and industrial etc. the facility transmission-system is to expire the electricity employed in power-utility system. The necessity of the electricity has been growing every day. To satisfy the demand new power stations are established and that they are interconnected to the grid. Because of this the transmission lines becomes over-loaded. So that, it's terribly essential to watch the flow of power at intervals the coming grids. So as to satisfy needs FACTS devices are utilized. Among all the device Distributed power flow controller (DPFC) is one in every of the most variable FACTS controller, as a result of it offers finest performance characteristics.

The DPFC comes from the unified power-flow controller (UPFC). The DPFC is thought-about as a UPFC with associate degree eliminated common dc link. The active power exchange between the shunt and series converters that is thru the common dc link within the UPFC is currently through the transmission lines at the third-harmonic frequency. The DPFC employs the distributed FACTS (D-FACTS) construct that is to use multiple small-size single-phase convertors rather than the one large-size three-phase series converter within the UPFC. The big range of series converters provides redundancy, thereby increasing the system reliability. Because the D-FACTS converters area unit single-phase and floating with relevancy the bottom, there's no high-voltage isolation needed between the phases. Consequently, the price of the DPFC system is less than the UPFC. The DPFC has a similar management capability because the UPFC, that contains the adjustment of the road resistivity, the transmission angle, and therefore the bus voltage. Throughout this paper, utterly totally different controller technique is planned for dominant of Distributed power flow controller. These reviews of various techniques are going to be helpful for future study and analysis within the field of Distributed power flow controller. That paper useful for college students and researcher those can operating within the field of Distributed power flow controller.

Key Words: Distributed Power Flow Controller (DPFC), Flexible AC Transmission System (FACTS)

1. INTRODUCTION

Recent analysis has been specializing among the design and realization of economical FACTS device by applying the distributed thought rather than the standard lumped answer. A Distributed Static Series Compensator (DSSC) was planned. Very low rated (1 – 20kW) converter and single flip device were applied to form a DSSC module that will be clamped to the transmission conductor to manage the active power. Undemanding and cheap, the DSSC is advantageous over lumped answer in active power flow controlling. Although the high device turns relation increases this level, the compensating voltage ability and power converter rating are restricted at constant time. As a result, associate outsized vary of DSSC modules are required to manage the positive active power flow through the power conductor.

Recently, Semiconductor Power physics Center (SPEC) of North Carolina geographical area State University has developed ETO light-weight metal normal voltage provide device (VSC). It's lower cost, higher reliability And high power density and could be totally housed in an enclosure whereas not additional user intervention. Consequently, ETO light-weight device has the potential to wide unfold the use of the quality voltage provide device in FACTS applications and various high power business applications.

A new plan was planned, noted as distributed power-flow controller (DPFC) that is derived from the UPFC. a similar as a result of the UPFC, the DPFC is prepared to manage all system parameters. The DPFC eliminates the common dc link between the shunt and series converters. The active power exchange between the shunt and conjointly the series converter is through the cable at the third-harmonic frequency. The series converter of the DPFC employs the distributed FACTS (D-FACTS) plan. Comparison with the UPFC, the DPFC have 2 major advantages: 1) low worth attributable to the low-tension isolation and conjointly the low half rating of the series converter and 2) high responsibility attributable to the redundancy of the series converters. This technique begins with presenting the principle of the DPFC, followed by its steady-state analysis.

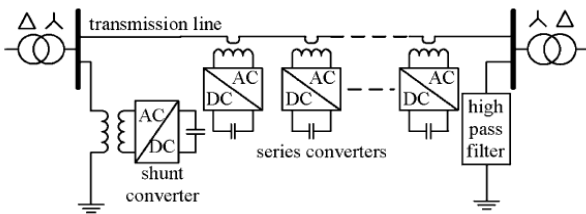

Fig-1: Configuration of DPFC

2. DIFFERENT TECHNIQUES FOR DPFC CONTROLLER

Flexible AC gear mechanisms (FACTS) devices will controlling power flow within the transmission system to boost plus utilization, relieve congestion, and limit loop flows. High prices and dependableness issues have restricted their use in these applications. The idea of distributed FACTS (D-FACTS) is introduced as the simplest way to get rid of these barriers [1]. A replacement device, the distributed static series compensator (DSSC), attaches on to existing HV or EHV conductors so doesn't need HV insulation. It will be factory-made at low value from standard industrial-grade elements. The DSSC modules area unit distributed, a couple of per conductor mile, to realize the specified power flow management practicality by effectively dynamic the road electrical phenomenon.

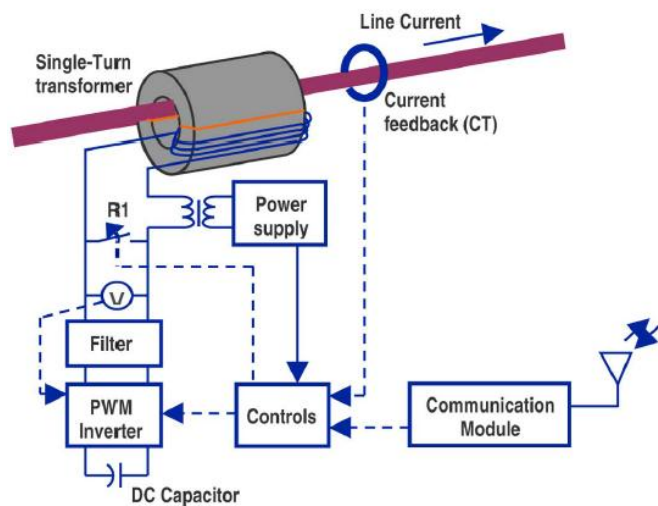

Fig-2: DSSC circuit schematic [1]

DSSC that uses multiple low-power single-phase inverters that bondable to the transmission conductor to dynamically management the impedance of the transmission line allowing management of active power flow on the conductor. The DSSC inverters square measure self-powered by induction from the transmission line itself, float electrically on the transmission conductors, and square measure controlled victimization wireless or conductor communication techniques. Implementation of system level management uses Associate in Nursinging oversized form of

DSSC modules that square measure deployed and management LED as a bunch to grasp active management of power flow. The DSSC could also be accustomed either increase or decrease the conductor impedance, allowing current to be 'pushed' aloof from or "pulled" into a line in Associate in Nursinging passing networked system. The DSSC plan overcomes variety of the foremost serious limitations of FACTS devices, and points the because of a innovative approach for achieving power flow control—the use of Distributed FACTS or D-FACTS devices.

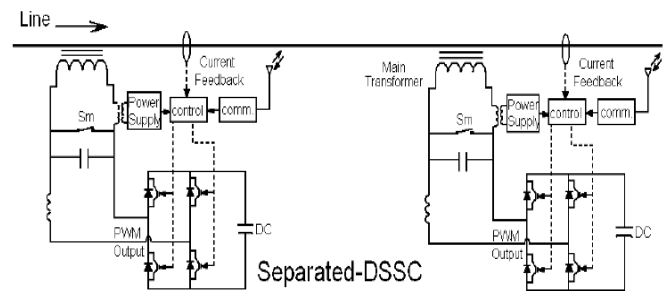

Fig-3: circuit schematic of separated-DSSC module [8]

Flexible AC Transmission Systems (FACTS) devices unit accustomed management flow of power inside the transmission line to alleviate congestion and limit loop flows. Due to, high value and responsibility problems the widespread preparation of FACTS solutions square measure restricted. The conception of Distributed FACTS (D-FACTS) devices, as associate alternate approach to realizing value effective power flow management, has been planned by whole totally different researchers. This technique discusses type of a singular Distributed FACTS management supported two half-bridge converter combined as associate alternate approach to know efficient power flow management [2]. For two separate-DSSC controllers, 2 management module circuits, 2 powers provide and 2 constitutional communications unit needed for each module. where at intervals the combined-DSSC, for each controller with an identical power output 2 separate modules, just one electrical circuit, power provide and constitutional communication is required. Finally with the configuration of the projected technique the quantity of components and equipment used unit reduced those leads to cost-efficiency and increasing the responsibility of these devices.

Static Synchronous Series Compensator (SSSC) is one amongst the solid state power physics technology primarily based versatile AC gear (FACTS) devices that's effective to manage the active power flow across the cables by sterilization or dynamical the characteristic electrical resistance of transmission line.

However its widespread application continues to be restricted by high costs, low irresponsibility and long build cycle. One altogether the methodology, a replacement ETO light-weight device based series compensating distributed power flow controller (DPFC) is introduced [3]. The projected single half customary power flow controller

system combines customary device, customary heat-pipe and customary digital interface designs to achieve customary single half management. Its intelligent functions just like the self-power and self-defense. Its interfaces are wholly optical fibers and simple for affiliation. The quality DPFC makes it possible to possess the device less affiliation to the prevailing grid. These specific designs cut back the worth and increase the irresponsibility greatly and introduce important blessings to the power system.

The ETO light-weight customary VSC contains a really easy configuration and fully customary vogue, which enable versatile and wide unfold use in FACTS applications and completely different business applications that require high power converters. The ETO light-weight converter based distributed power flow controller conception overcomes some serious limitations of FACTS devices like high worth, low responsibility and long building cycle. The new approach shed lights on the high power converter applications in FACTS. The controller of DPFC is simulated and verified.

The DPFC has the same capability as a result of the UPFC, but with verdant lower worth and higher responsibility [4]. The method presents the experimental results of the DPFC throughout a scaled easy facility. The target of this DPFC experimental setup is to verify the principle of victimization third harmonic to exchange active power between shunt and series converters. Several converters unit created, and each is controlled by a personal DSP. It proves that the DPFC can severally management active and reactive power flow through the road. The DPFC experimental setup aims to verify the DPFC thought, different and other converters and a scaled network unit created. The first results of the DPFC setup are presented and a couple of cases unit demonstrated: one operation purpose of the DPFC in steady-state and conjointly the step of the reference series voltage response of the DPFC. As shown, the active power could also be successfully exchange between the shunt and series converters, and conjointly the series converters have the power of every active and reactive compensating the cable. Distributed Power Flow Controller could also be a brand new device within the family of FACTS. The DPFC has identical management capability as a result of the UPFC, but with pr lower worth and higher dependability. This technique addresses one amongst the applications of the DPFC significantly compensation of unbalanced currents in transmission systems [5]. Since the series converters of the DPFC square measure single half, the DPFC can compensate every active and reactive, zero and negative sequence unbalanced currents. To compensate the unbalance, 2 more current controllers square measure supplemented to control the zero and negative sequence current severally.

It is found that the DPFC can compensate every negative and zilch sequence parts; consequently the DPFC is further powerful than totally different FACTS device for compensation of unbalanced currents. Additional controller's area unit supplemented to existing DPFC controller and their principle is to look at the negative and zilch sequences of this through the road, associated to force

them to be zero by applying associate degree opposing voltage. As side result, the DPFC generates non-zero sequence third current throughout the unbalance state of affairs, which cannot be blocked by the Y-Δ device. However the magnitude of the non-zero sequence third current is much smaller than the nominal current at the basic frequency, however multidimensional typically.

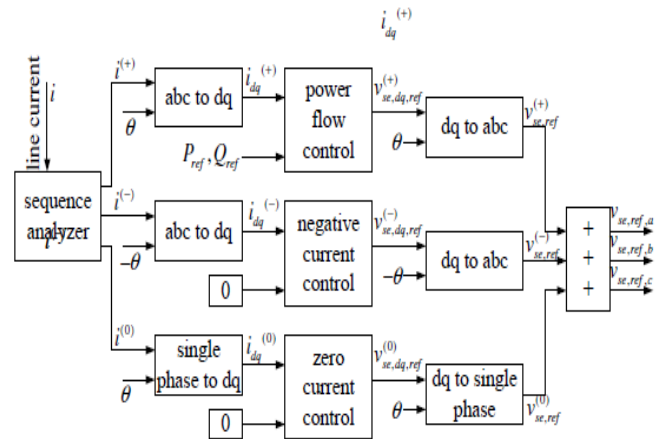

Fig-5: Control scheme for unbalance compensation

With the relief of the electrical power markets the everyday distance between power generation and consumption can increase that end in an increase in utilization of positive transmission corridors connecting e.g. off-shore wind parks to areas of high demand (industrial and concrete districts). Together with rising power demand and thus the mixing of high-capacity unpredictable renewable resources (e.g. volatile wind power) these factors produce a challenge to today's transmission networks. Operators need to be compelled to ensure a stable and economical operation of the grid. a way to spice up the stability And efficiency of the prevailing network aside from high-priced Associate in Nursinging most often very long reconstruction is that the mixing of power flow controllers (PFCs) therefore on dynamically direct power flows removed from critically loaded resources that may be vulnerable by an overload and thus (with the plain disadvantage of higher transmission losses) accomplish following degree of gettable capability utilization. throughout this system outline our current work on the event of a multi-agent-based data processing of PFCs [6] that permits for Associate in Nursinging autonomous distributed coordination of fast power flow controlling actions across (international) management areas whereas not the requirement for world information.

In one among the man oeuvre, written in nursing autonomous multi-agent system for the coordination of fast PFCs in transmission networks. The system operates absolutely distributed inside the sense that it's no class-conscious organization below leader management utilizing world information but instead consists of uniform code agents possessing only domestically accessible information regarding the state of their corresponding active (controlling) or passive (non-controlling) device or line,

severally, and conjointly the identifiers of the devices directly connected to them. The information necessary to identify and ensure the impact of a bearing action is about from periodically transmitted State Inform Messages. The transmission vary of these messages is prohibited by the accumulated path impedances of traversed lines as messages area unit invariably propagated via neighboring devices and so in line with the constellation.

The information propagated through these messages is known and used to construct nodal admittance matrices consisting of those lines a halocarbon has important impact on. This "significance" is ready by sensitivities that are on the one hand calculated through a DC-power flow supported the admittance matrix and on the alternative hand determined by the dynamic loading of a given line, allowing critically loaded lines to be controlled by extra (and presumptively farther away) PFCs. This driving approach permits for associate adequate reaction on line failures even at a lower place otherwise conflicting (conventional emergency) management requests.

Modern power utilities have to be compelled to reply to sort of challenges like growth of electricity demand particularly in non-linear a whole bunch in power grids, consequently, some policies regarding the ability with a much better quality have to be compelled to be thought of. Distributed power flow controller (DPFC) that's cherish unified power flow controller (UPFC) in structure, is used to mitigate the voltage sag associated swell as an influence quality issue. Not like UPFC, the common dc-link in DPFC, between the shunt and series convertors is eliminated and three-phase series device is split to several single-phase series distributed convertors through the conductor. Put together to sight the voltage sags and verify the three single-phase reference voltages of DPFC, the synchronous system technique is projected [7].

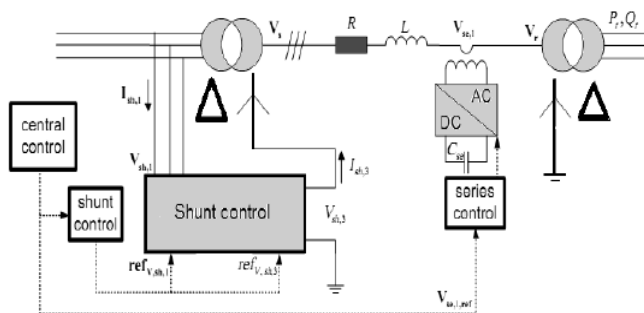

Fig-6: DPFC control structure [13]

The power quality improvement of the ability transmission systems is associate degree very important issue in power trade. During this study, the applying of DPFC as a replacement FACTS device, within the voltage sag and swell mitigation of a system composed of a three-phase supply connected to a non-linear load through the parallel transmission lines is simulated in Matlab/Simulink surroundings. The voltage dip is analyzed by implementing a three-phase fault near to the system load. To sight the

voltage sags and confirm the 3 single part reference voltages of DPFC, the SRF methodology is employed as a detection and determination methodology. The obtained simulation results show the effectiveness of DPFC in power quality improvement, particularly in sag and swell mitigation.

Flexible AC Transmission Systems (FACTS) devices are going to be used for power flow management in AC transmission grids, up cable utilization and performance. Nowadays, Unified Power Flow Controllers (UPFC) ar one in each of the foremost useful FACTS, allowing the coinciding management of the bus voltage and line active and reactive power. However, because of high costs and untrustworthiness issues, the utilization of this technology has been restricted in such applications.

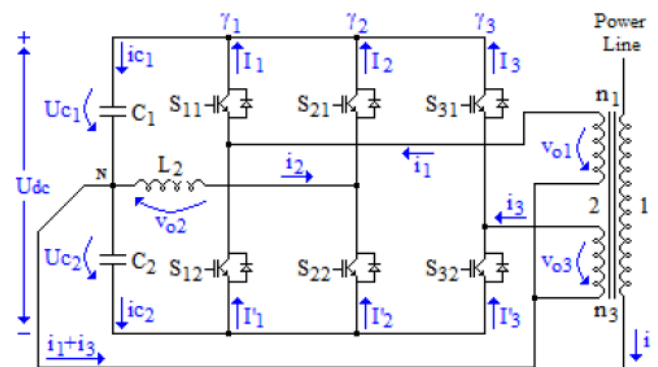

Fig-7: DPFC converter topology [14]

For the projected device the amendment state-space models were obtained and thus the system laws of the alternating output voltages were studied exploitation the sliding mode management methodology. The device amendment laws were printed therefore a vector controller of the ac voltages of the device were obtained.

When a steam Turbine-Generator is connected to a series stipendiary long line, degree adverse development significantly Sub-Synchronous Resonance (SSR) might occur. The foremost purpose of this work [9] is to verify the power of the Distributed Static Series Compensator (DSSC) as a member of D-FACTS family in mitigating the SSR. A pair of novel controllers as: the Particle Swarm optimization (PSO)-based typical Damping Controller (CDC) and conjointly the mathematical logic based Damping Controller (FLBDC) unit of measurement designed and implemented in ancient controller of the DSSC thus on provide the effective damping. The system stability is studied through time domain simulations, fast Fourier make over (FFT) analysis, and a Performance Index (PI) that's printed supported the dynamics of the flexibility system. Simulation results unit of measurement disbursed with MATLAB/Simulink on the IEEE Second Benchmark Model (SBM) mass with the DSSC modules. Three varied cases of study unit of measurement thought of thus on match the operation of the projected FLBDC with the PSO based administrative unit in varied transient states.

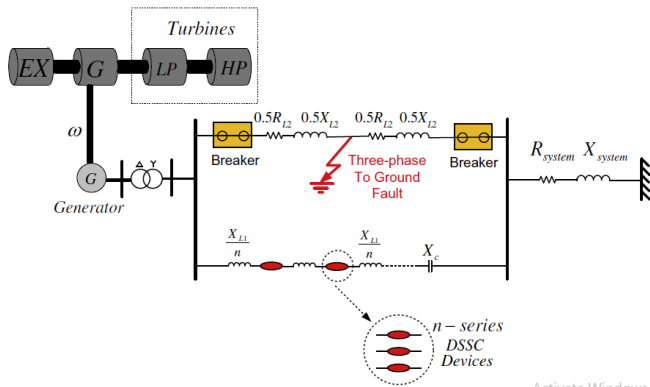

Fig-8: The IEEE SBM model aggregated with DSSC for SSR analysis [15]

In this work [10], the potential of a brand new D-FACTS device particularly the DSSC in SSR suppression is interrogated. Because of the actual fact that the standard controller of the DSSC isn't capable of mitigating the SSR, a fuzzy logic primarily based damping controller is intended and granted to the standard controller of the DSSC. It's been shown that, the designed controller not solely is capable of mitigating the SSR, however conjointly it will alleviate the low frequency oscillations.

In order to higher assess the potential of the planned FLBDC, a PSO primarily based authority is additionally designed and granted to the standard controller of the DSSC so as to suppress the SSR. Varied cases of study are enclosed for comprehensive investigation of the SSR development. Simulation results verify that, the planned FLBDC has superior performance than its counterpart PSO primarily based authority in SSR suppression in inclined fault conditions. What is more, in abnormal conditions, the PSO primarily based authority isn't capable of mitigating the oscillations and also the system could become unstable, however the planned FLBDC isn't associated with the system condition and it will mitigate the SSR even in harsh conditions. It ought to be noted that, the FFT analysis in generator rotor speed is additionally conducted to verify the results. Finally, 2 performance indexes are outlined supported sinking time and overshoot of the system. The results from calculation of performance indexes conjointly verify the superior performance of the planned FLBDC than the PSO primarily based authority in SSR alleviation.

Sub-synchronous resonance (SSR) could be a frequent adverse development in series-compensated lines, threatening either or each mechanical power and installation stability. It's wide accepted that Flexible AC Transmission system (FACTS) will offer a good resolution to alleviate the SSR. On the opposite hand, the arrival of distributed FACTS (D-FACTS) technology has diode to additional economical readying of the flexible devices within the installation management. This work focuses on confirmatory the potential of the distributed power flow controller (DPFC) to alleviate the SSR [16]. As a member of the D-FACTS family, the DPFC operates within the same manner because the

unified power flow controller (UPFC). Compared with UPFC, the DPFC has some benefits like higher management capability, cheaper price, and additional responsibility. The DPFC impact on SSR mitigation is interrogated in numerous case studies, namely, with the SSR damping (SSRD) controller on the series convertor, with SSRD controller on the shunt convertor and with each at the same time operative.

The best case for SSR mitigation is achieved once the DPFC is furnished 2 SSRD controllers at the same time. Simulations are meted out with Power Systems pc motor-assisted Design/ magnetic force Transients as well as DC (PSCAD/EMTDC) on the Institute of Electrical and physics Engineers (IEEE) initial SSR benchmark model aggregative with DPFC on the cable.

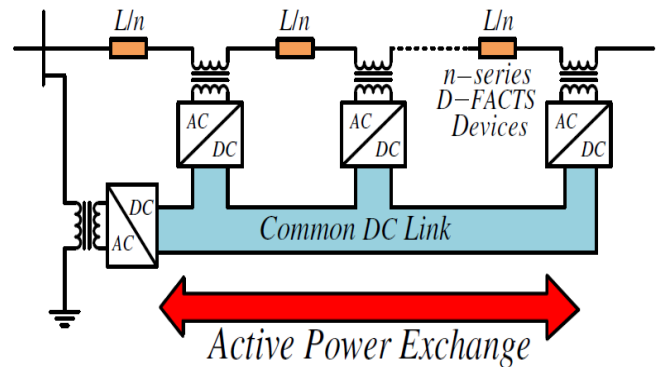

Fig-9: DPFC with common DC link between converters [16].

Recently, among the family of FACTS, the distributed power flow controller is an extra device. One among the tactic highlights on voltage sag mitigation that is one among the burgeoning power quality problems. It deals with the operating construct of distributed power flow controller for compensating unbalanced 3 section line currents within the gear.

The single section series converters of DPFC area unit able to compensate active furthermore as reactive [11], negative and nil sequence unbalanced currents. During this methodology the performance of the DPFC has been studied by considering line to ground fault close to the load finish. The MATLAB/SIMULINK results obtained shows associate degree improved performance in voltage sag mitigation, unbalance compensation, exceptional reduction in load voltage harmonics and additionally increased power flow management.

One of the methodology, introduced a replacement series-shunt kind FACTS controller referred to as distributed power flow controller to boost associated maintain the power quality of an power system [12]. This DPFC technique is same because the UPFC accustomed compensate the voltage sag and also the current swell these area unit voltage based mostly power quality issues. As compared to UPFC the common dc link electrical condenser is removed and 3 individual single section devices area unit used rather than a

3 section series converter. Series referral voltages, branch currents area unit employed in this paper for coming up with feedback circuit. The evaluated values area unit obtained by mistreatment MATLAB/SIMULINK.

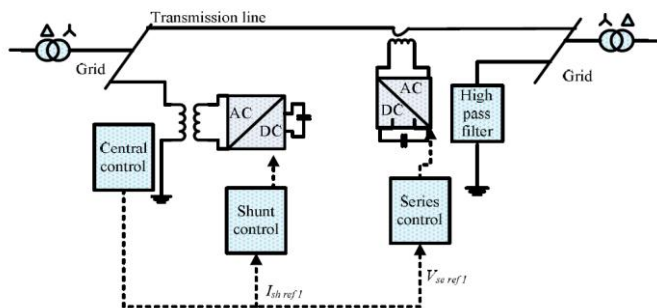

Fig-9: Block diagram of central controller of the DPFC [17]

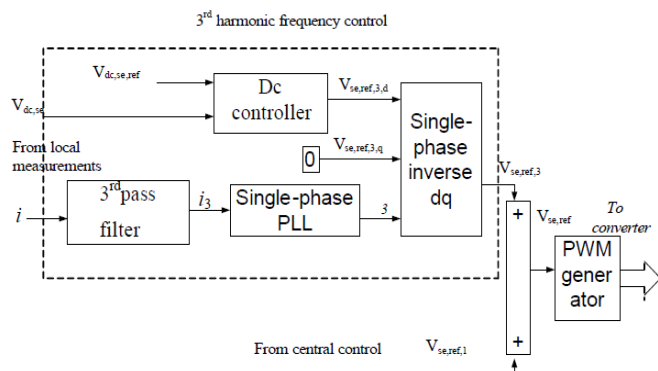

Fig-10: DPFC series control structure

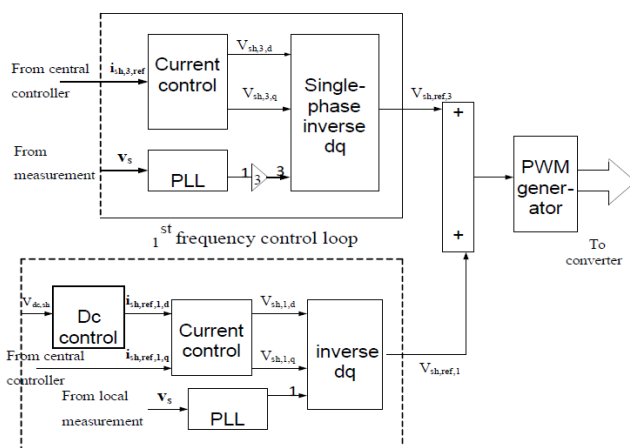

Fig-11: DPFC shunt control structure

Flexible AC transmission system (FACTS) controls power flow through line. Distributed power flow controller could be a Distributed-FACTS device that provides price effective and reliable power flow control through existing line. One among the methodology presents distributed static series compensator (DSSC) as a distributed power flow controller [13]. It's low price modules that may be hooked up directly on existing line victimization single flip electrical device.

MATLAB Simulation results shows important power flow management through line victimization DSSC devices.

4. CONCLUSION

This paper investigates the controllability of the DPFC to balance a network. It's found that the DPFC will compensate each negative and zero sequence elements, consequently the DPFC is a lot of powerful than alternative FACTS device for compensation of unbalanced currents. Extra controllers square measure supplemented to existing DPFC controller, and their principle is to observe the negative and zero sequences of this through the cable, associated to force them to be zero by applying an opposing voltage.

During this paper, completely different controller technique is planned for dominant of Distributed power flow controller. This review of different techniques will be useful for future study and research in the field of Distributed power flow controller. That paper helpful for students and researcher those will working in the field of Distributed power flow controller.

REFERENCES

- [1] Divan, Deepak, et al. "A distributed static series compensator system for realizing active power flow control on existing power lines." Power Systems Conference and Exposition, 2004. IEEE PES. IEEE, 2004.
- [2] Amiri, M., Mo Amiri, and E. Afjei. "A novel distributed FACTS controller based on combined two half-bridge inverter." Electric Power Conference, 2008. EPEC 2008. IEEE Canada. IEEE, 2008.
- [3] Song, Wenchao, Alex Q. Huang, and Subhashish Bhattacharya. "Distributed power flow controller design based-on ETO-light converter." Applied Power Electronics Conference and Exposition, 2008. APEC 2008. Twenty-Third Annual IEEE. IEEE, 2008.
- [4] Yuan, Zhihui, Sjoerd WH de Haan, and Jan A. Ferreira. "Construction and first result of a scaled transmission system with the Distributed Power Flow Controller (DPFC)." Power Electronics and Applications, 2009. EPE'09. 13th European Conference on. IEEE, 2009.
- [5] Yuan, Zhihui, et al. "Utilize distributed power flow controller (DPFC) to compensate unbalanced 3-phase currents in transmissions systems." Electric Power and Energy Conversion Systems, 2009. EPECS'09. International Conference on. IEEE, 2009.
- [6] Jamshidi, Ahmad, S. Masoud Barakati, and M. Moradi Ghahderijani. "Impact of Distributed Power Flow Controller to Improve Power Quality Based on Synchronous Reference Frame Method." International Journal of Engineering and Technology 4.5 (2012): 581.

[7] Martins, Ivo M., et al. "Control of distributed power flow controllers using active power from homopolar line currents." Optimization of Electrical and Electronic Equipment (OPTIM), 2012 13th International Conference on. IEEE, 2012.

[8] Khazaie, Javad, et al. "Sub-Synchronous Resonance damping using Distributed Static Series Compensator (DSSC) enhanced with fuzzy logic controller." International Journal of Electrical Power & Energy Systems 43.1 (2012): 80-89.

[9] F. M. Uriarte et al., "A DC arc model for series faults in low voltage microgrids," IEEE Trans. Smart Grid, vol. 3, no. 4, pp. 2063–2070, Dec. 2012.

[10] Khazaie, Javad, et al. "Sub-synchronous resonance mitigation via distributed power flow controller." International Transactions on Electrical Energy Systems 23.6 (2013): 751-766.

[11] Gupta, Santosh Kumar, and Shelly Vadhera. "Performance of distributed power flow controller on system behavior under unbalance fault condition." Engineering and Systems (SCES), 2014 Students Conference on. IEEE, 2014.

[12] Kumar, K. Sai, and D. Narasimha Rao. "Simulation of Distributed Power Flow Controller for Voltage Sag Compensation." Indian Journal of Science and Technology 8.23 (2015).

[13] Gaigowal, Sandeep R., and M. M. Renge. "Distributed power flow controller using single phase DSSC to realize active power flow control through transmission line." Computation of Power, Energy Information and Communication (ICCPEIC), 2016 International Conference on. IEEE, 2016.