

SMART TROLLEY FOR GUIDING CUSTOMERS IN SUPER MARKETS USING AOT

ELAMATHI K¹, SOWMIYA S², SREEMATHY R³, VICHITRA V⁴, KEERTHANA P⁵

¹Assistant Professor, Department of Electronics and Communication Engineering,
^{2, 3, 4, 5}BE, Final Year, Department of Electronics and Communication Engineering,
Muthayammal Engineering College, Tamil Nadu, India.

Abstract – The super shops are the places where people go to buy their daily using products and also pay for that. So the need to calculate the number of products sold and generation of the bill for the customer. When people go for the shopping in a shop, we have to select the right product. After that, it's a hectic to stand in line for billing purpose. Hence, we are going to propose the "Smart Shopping Cart System" that will save the track of products which are purchased and calculate the bill using RFID reader, Transmitter and Receiver. The system will also provide suggestions for products to buy based on user purchase history from a centralized system. In "Smart Shopping Cart System" every product in Mart will be attached with RFID tag, and every cart will be having RFID Reader, LCD display and Transmitter and receiver attached to it.

Key Words: AOT, WSN, RFID, Smart Sensors, Raspberry Pie.

1. INTRODUCTION

In metro cities purchasing and shopping at super shops, big malls are a daily activity. We have seen big lines for payment of the bill at malls on holidays and weekends. When there are special offers and discount the rush is also even more. Customers will purchase many items and put it into the trolley. After customers done the purchase they need to go to billing counter for payment. At the billing counter the customer will prepare the bill using bar code reader which is a time consuming process and will creates the long queues at billing counters. All the products in the shop are attached with RFID tags.

When a customer put any products in the trolley, its unique code will be detected and the price of those products will be get stored in memory. As we put the products into the trolley then costs will automatically get added to total bill. Thus the billing will be done in the trolley itself. Total bill information will be transferred to PC by wireless Transmitter and receiver modules at the billing counter. When the customer purchase a product, she/he first scans the RFID tag of the product using the RFID reader and then put it into the trolley. While purchasing the products customer needs to scan the RFID tag of the product, a price of the product is taken and stored in the system's memory.

2. LITERATURE SURVEY

Nowadays, shopping has become major role in our economic activity. Basically, Innovation in technology is aimed towards making day to day life of people easier and faster. In this paper, we discuss a product "Smart shopping trolley for supermarkets using rechargeable smart card" being developed to help customer in terms of reduced time spent while shopping. The main objective of proposed system is to provide a technology oriented, easily handled, and efficient system for helping the customers in shopping. The main facility that the proposed model provides is the customer only needs to carry a smart card, which is needed to be swiped in the trolley to initiate shopping when a customer places a product in the smart trolley, the RFID Reader will read the Product ID and the information related to it will be stored in Arduino UNO. When shopping is over the customer have to press the end button which will automatically deduce the bill amount from the balance available in the smart card. The payment is made right there and thus avoiding the need of waiting in queue at counter and saving large amount of time. The smart card is rechargeable.

3. SMART TROLLEY FOR SUPER MARKET BILLING SYSTEM

In this project to avoid the long queue in billing section to introducing smart trolley technology in all super market for considers those difficulties. To proposed the system implementation WSN (Wireless Sensor network) using microcontroller as a technology. To implement the RFID (Radio Frequency Identification) in the shopping trolley save the shopping time, to calculate the barcode in a material, calculating the total amount for the thing added in the purchasing trolley. An RFID Reader with electronics hardware system is fitted with the trolley to make the purchase comfortable. When the item is shown in front of the reader (fitted in the trolley) the amount for the item is added to the purchase bill and it is shown on the LCD (Liquid Crystal Display). It also has the provision for removing the items from the trolley where the cost is reduced from the total cost. All this information is send to a computer for billing update through a wireless link. This facilitates the billing system even faster and reduces time.

3.1. AUTOMATED SHOPPING TROLLEY FOR SUPERMARKET BILLING SYSTEM

The Automated Shopping Trolley is a Smart Trolley which integrates a Raspberry Pie Embedded Chip with two Bar code Scanners and a Battery kit to allow users to self checkout at Super Markets. In the modern world, every supermarket and hypermarkets employ shopping baskets and shopping trolleys in order to aid customers to select and store the products which they intend to purchase. The customers have to drop every product which they wish to purchase into the shopping cart and then proceed to checkout at the billing counter. The billing process is quite tedious and highly time consuming and has created the need for shops to employ more and more human resource in the billing section, and yet waiting time remains considerably high. In this paper, we seem it fit to propose the “Intelligent Shopping Basket” which aims to reduce ,and possibly eliminate the total waiting time of customers, lower the total manpower requirement and expenses for markets and increase efficiency overall. In a world where technology is replacing the ways we pursue everyday activity, the future of the retail industry also lies in more and more automated devices.

4. WORKING PRINCIPLE

In the modern world, every supermarket and hypermarkets employ shopping baskets and shopping trolleys in order to aid customers to select and store the products which they intend to purchase. The customers have to drop every product which they wish to purchase into the shopping cart and then proceed to checkout at the billing counter. The billing process is quite tedious and highly time consuming and has created the need for shops to employ more and more human resource in the billing section, and yet waiting time remains considerably high.

In this project, we seem it fit to propose the “Intelligent Shopping Basket” which aims to reduce ,and possibly eliminate the total waiting time of customers, lower the total manpower requirement and expenses for markets and increase efficiency overall. In a world where technology is replacing the ways we pursue everyday activity, the future of the retail industry also lies in more and more automated devices.

This system has two methods

1. Automatic mode
2. Manual mode

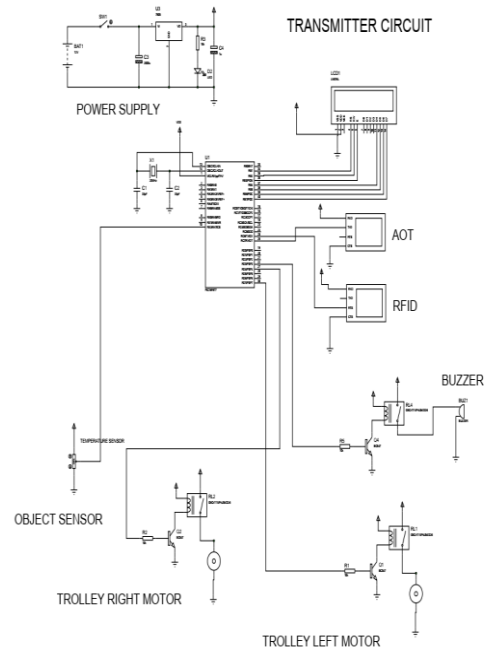
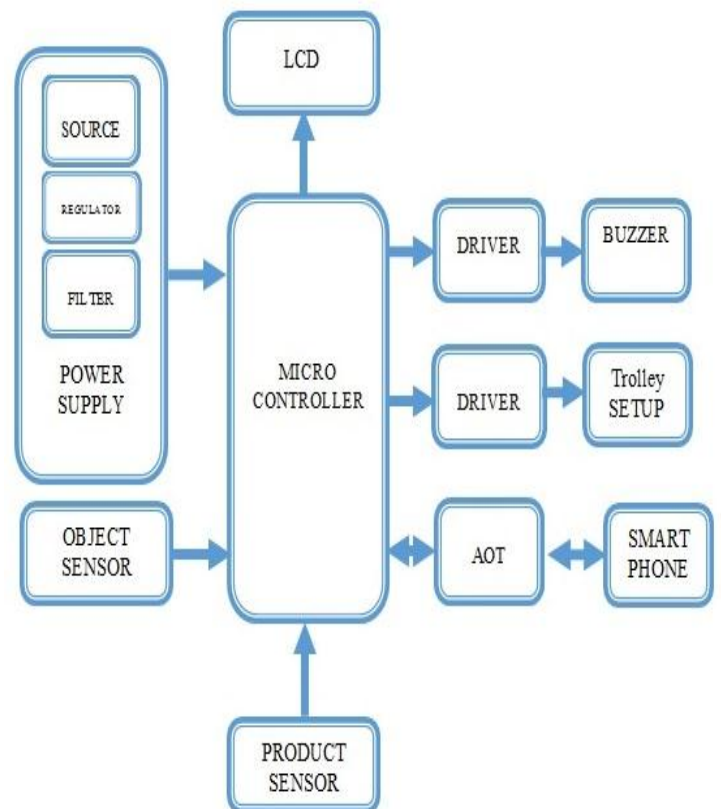

Fig-1: Circuit Diagram

5. BLOCK DIAGRAM



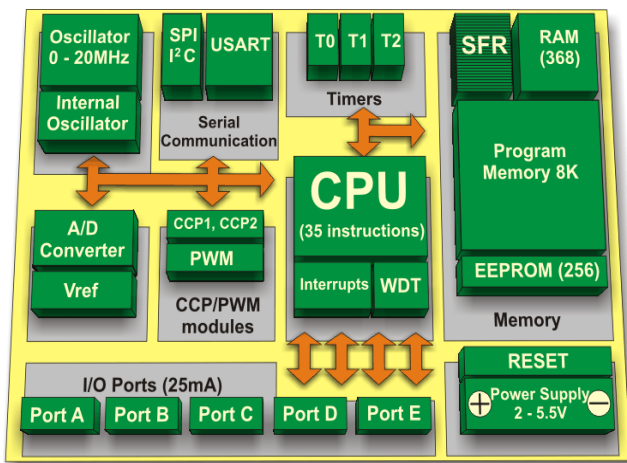

FIG-2: BLOCK DIAGRAM

5.1. PIC16F887A MICROCONTROLLER

PIC16F877 belongs to a class of 8-bit microcontrollers of RISC architecture. It has 8kb flash memory for storing a written program. Since memory made in FLASH technology can be programmed and cleared more than once, it makes this microcontroller suitable for device development. IT has data memory that needs to be saved when there is no supply. It is usually used for storing important data that must not be lost if power supply suddenly stops. For instance, one such data is an assigned temperature in temperature regulators. If during a loss of power supply this data was lost, we would have to make the adjustment once again upon return of supply.

5.2. PIN DIAGRAM

MICROCONTROLLER

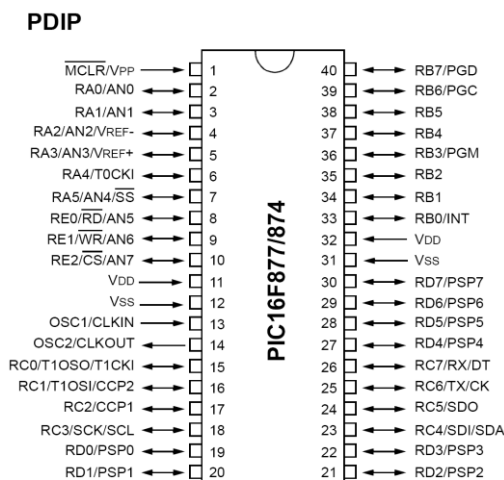

FIG-3: PIC16F877/874 Microcontroller

6. RFID

RFID is short for Radio Frequency Identification. Generally a RFID system consists of 2 parts. A Reader, and one or more Transponders, also known as Tags. RFID systems evolved from barcode labels as a means to automatically identify and track products and people. systems as seen in:

- Access Control. RFID Readers placed at entrances that require a person to pass their proximity card (RF tag) to be "read" before the access can be made.
- Contactless payment Systems. RFID tags used to carry payment information. RFIDs are particularly suited to electronic Toll collection systems. Tags attached to vehicles, or carried by people transmit payment information to a fixed reader attached to a Toll station. Payments are then routinely deducted from the users account, or information is changed directly on the RFID tag.
- Product Tracking and Inventory Control. RFID systems are commonly used to track and record the movement of ordinary items such as library books, clothes, factory pallets, electrical goods and numerous items.

Basic RFID systems consist of three components:

- An antenna or coil
- A transceiver (with decoder)
- A transponder (RF tag) electronically programmed with unique information

6.1. PIN DIAGRAM

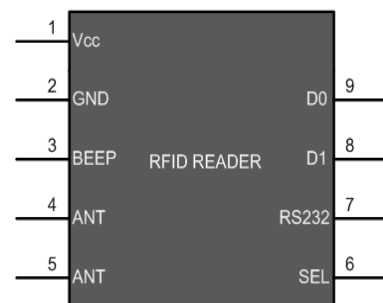

FIG-4: RFID Pin Diagram

6.2. CONNECTION DIAGRAM

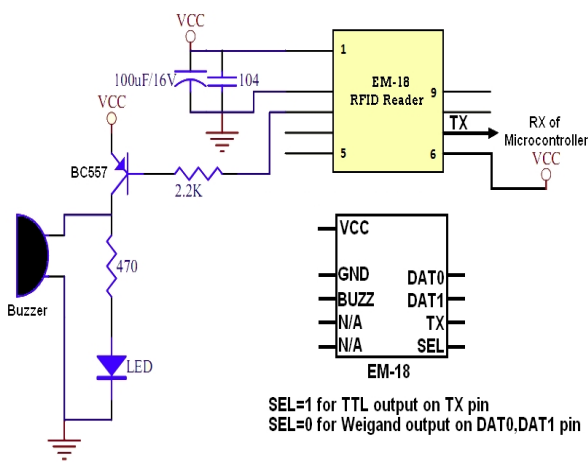

FIG-5: RFID Connection Diagram

7. FLOW CHART

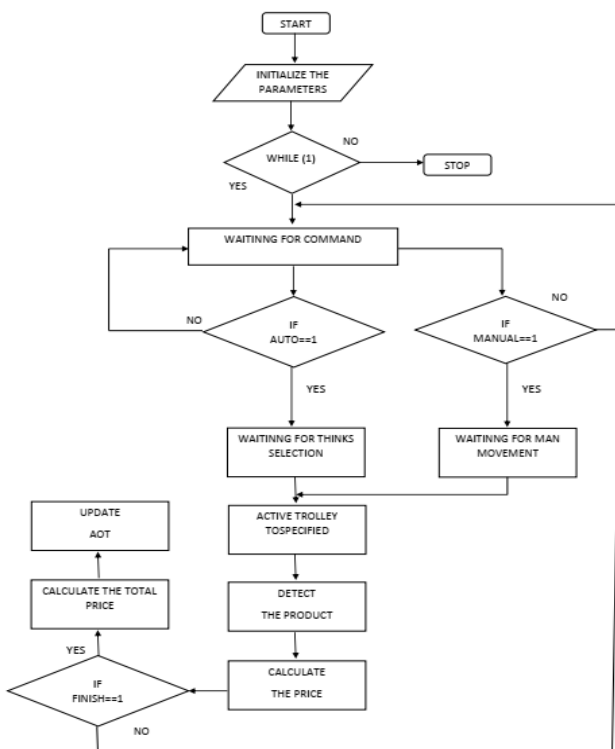

FIG-6: Flow chart

8. CONCLUSIONS

Experience with Smart Shopping has indicated that there are many technical challenges will be met in deploying a pervasive retail system. Technologies that capture information about interactions between physical products are not yet mature enough for the consumer market as they are relatively costly. Even when such data is available the task of interpreting it is often as challenging as its registration, since no standardized classification scheme or appropriate taxonomy exists. Several efforts to create standards are underway but are still at least years away. Although in the relatively controlled environment of the smart shopping trolley project it has been possible to address this problem on a wireless basis it is hard to envision a situation where widely deployed retail services can operate without such standards. A related problem is that new systems must be integrated in existing retail infrastructures, which often operate using legacy and incompatible systems. Moreover, the deployment of retail causes significant growth in electronic transaction loads which current systems are unable to cope with. Like smart shopping should be available on whatever device consumers have at hand. Although considerable Advances have been made in this area, developing and maintaining such applications is still a major challenge.

REFERENCES

1. Mr.P. Chandrasekar and Ms.T. Sangeetha "Smart Shopping Cart with Automatic Billing System through RFID and Transmitter and Receiver ",IEEE,2014.
2. Ms.Vrinda, Niharika, "Novel Model for Automating Purchases using Intelligent Cart," e-ISSN: 2278-0661, pISSN: 2278-8727Volume16,Issue 1, Ver. VII (Feb. 2014), PP 23-30.
3. Ms.RupaliSawant, Kripa Krishnan, Shweta Bhokre, Priyanka Bhosale "The RFID Based Smart Shopping Cart", International Journal of Engineering Research and General Science Volume 3, Issue 2 pp 275-280, March-April, 2015.
- 4.KalyaniDawkhar,ShraddhaDhomase,SamruddhiMahabaleshwarkar "Electronic Shopping Cart For Effective Shopping based on RFID", International Journal of Innovative Research In Electrical, Electronic, Instrumentation And Control Engineering Vol. 3, Issue 1 pp 84-86, January 2015.
5. Zeeshan Ali, ReenaSonkusare, " RFID Based Smart Shopping and Billing ", International Journal of Advanced Research in Computer and Communication Engineering, Vol. 2, Issue 12, December 2013

2, Issue 12, December 2013

BIOGRAPHIES

K.Elamathi, is currently working as an Assistant professor, Department of Electronics and Communication Engineering, Muthayammal Engineering College, Rasipuram, Namakkal Dist. He is graduated in Electronics and Communication Engineering from Dhanalakshmi Srinivasan College of Engineering and Technology and M.E.,Degree (Embedded System) from Sathyabama University.



V.Vichitra, is currently pursuing her Bachelor of Engineering in the stream of Electronics and Communication Engineering, Muthayammal Engineering College, Rasipuram, Namakkal Dist.



S.Sowmiya, is currently pursuing her Bachelor of Engineering in the stream of Electronics and Communication Engineering, Muthayammal Engineering College, Rasipuram, Namakkal Dist.



R.Sreemathy, is currently pursuing her Bachelor of Engineering in the stream of Electronics and Communication Engineering, Muthayammal Engineering College, Rasipuram, Namakkal Dist.



P.Keerthana,, is currently pursuing her Bachelor of Engineering in the stream of Electronics and Communication Engineering, Muthayammal Engineering College, Rasipuram, Namakkal Dist.