

## O-RING INSERTION BY AUTOMATION

**Jeevanantham.G<sup>1</sup>, Sathiesh.V<sup>2</sup>, Velarasan.M.A<sup>3</sup>, Ravikumar.M<sup>4</sup>**

<sup>1</sup> Student, Mechanical, Bannari Amman Institute of Technology, Erode, Tamilnadu.

<sup>2</sup> Student, Mechanical, Bannari Amman Institute of Technology, Erode, Tamilnadu

<sup>3</sup> Assistant Professor, Mechanical, Bannari Amman Institute of Technology, Erode, Tamilnadu

<sup>4</sup> Professor and Head, Mechanical, Bannari Amman Institute of Technology, Erode, Tamilnadu

\*\*\*

**Abstract** - This paper focuses on the objective of **inserting rubber O-ring** in the outer cylindrical surfaces, especially for the outer faces of pipes in order to eliminate leaks and over tightening. The traditional way of inserting O-ring in pipe industries involves lot of time and the use of skilled labour

The main aim of this paper is to give effective solution to this problem by using **automation involving pneumatic actuators for O-ring insertion**. The main objective is to reduce the assembly time, increase accuracy and eliminate the use of skilled labour.

### 1. INTRODUCTION

O-Rings are one-piece moulded objects that made from elastometric seal with circular cross-section. They are used to prevent fluid movement between mechanical parts by maintaining contact with the inner and outer walls enclosing the ring. The resiliency of the rubber provides a zero-pressure seal. When pressure is applied, the fluid forces the O-Rings across the groove and causes more deformation. This leads to the ring flow up to the fluid passage and seal it against leakage. O-Rings are an example of self-energize seals, meaning they relay pressure inside the pipe to give them the pressure necessary to form the seal.

Automation in piping industry has advantages of higher production rates and increased productivity, more efficient use of materials, better product quality, improved safety, shorter workweeks for labour, and reduced factory lead times. Higher output and increased productivity have been two of the biggest reasons in justifying the use of automation.

### 2. O-RING INSERTION

O-Rings are inserted into cavities called glands, and they are used in either axial or radial seal designs. When installed, an O-Ring compresses and deforms slightly into the free space within the grove to form a proper seal. The ring's cross-section is approximately 20 percent greater than the gland depth and the groove width is about 1.5 times larger than the ring's width.

The O-Rings are first expanded and then inserted into the groove. For the expansion grippers can be used.

### 2.1. O-Ring Pick and place

It is evident the O-rings are to be picked up from the place where they are singled and to be placed on the gripper where it is expanded. For the picking of the O-ring and the expansion of the O-ring grippers can be used.

Since the main aim is to decrease the insertion time pneumatic actuators can be used for the operations. The pick and place consists of a two jaw gripper with end stopper that positions the O-ring in the expansion gripper. The process can be started by feedback from the sensors placed in the singling unit that ensures the presence of the O-ring after singling.

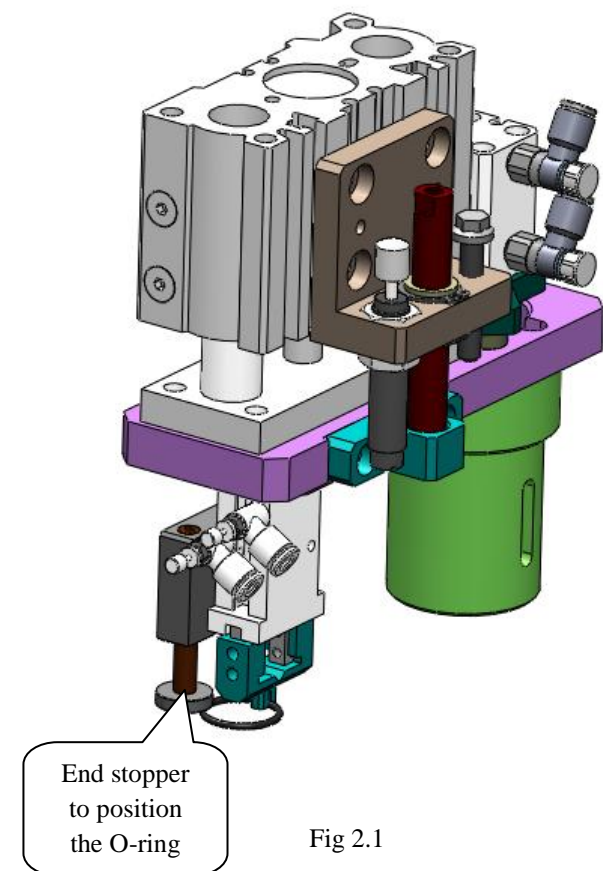

Fig 2.1

### 2.2. O-RING EXPANSION

The O-ring is placed in the gripper, as the jaws of the gripper move outwards the O-ring expands. The expansion of the O-ring is sufficient enough for the tool to be inserted. The finger of the gripper is designed in a way to place the O-ring in the place. The expansion of the O-ring can be done statically in a place by the use of a three jaw gripper.

The gripper is to be designed in such a way the initial closing position of gripper the outer diameter of the fingers must be smaller than the inner diameter of the O-ring and in the open position of the gripper the inner diameter of the gripper must be greater than the outer diameter of the O-ring inserting tool. The height of the gripper tool is to be limited so that it does not affect the picking by the inserting tool.

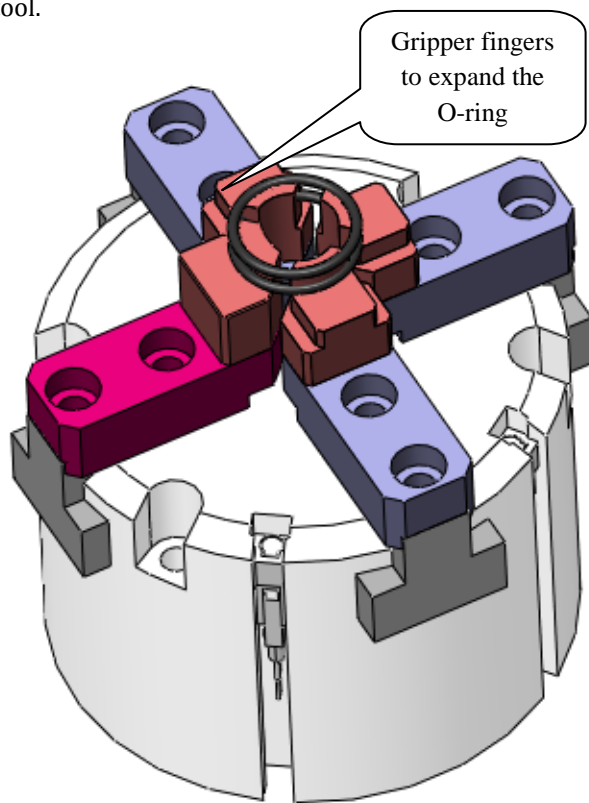

Fig 2.2

### 2.3. O-RING INSERTION BY TOOL

The expanded O-ring is picked up by the inserting tool from the expanding gripper and is inserted into the groove of the pipe or tap. For the movement to position the tool in the places of the gripper and the fixture where the component in which the O-ring is to be inserted pneumatic actuators (cylinders) are used.

The tool is designed in such a way that it does not disturb the component on fixture while inserting and the gripper fingers while picking the expanded O-ring. The tool have a notch along the outer surface for the O-ring to be seated.

While picking the O-ring, the O-ring is placed in the notch and the actuators move the tool to the next position which is the component in the fixture. During the inserting process the expanded O-ring which is in the tool is moved down along with the tool around the component in the fixture by the use of a vertical actuator.

The O-ring in the tool that is moved down is inserted in to the groove in component by the downward movement of the casing that just slides around the tool. As the casing moves downward the expanded O-ring that is held in the notch of the tool is moved down released in the groove of the component. The position where the O-ring is to be inserted can be adjusted by controlling the movement of the vertical cylinder that moves the tool

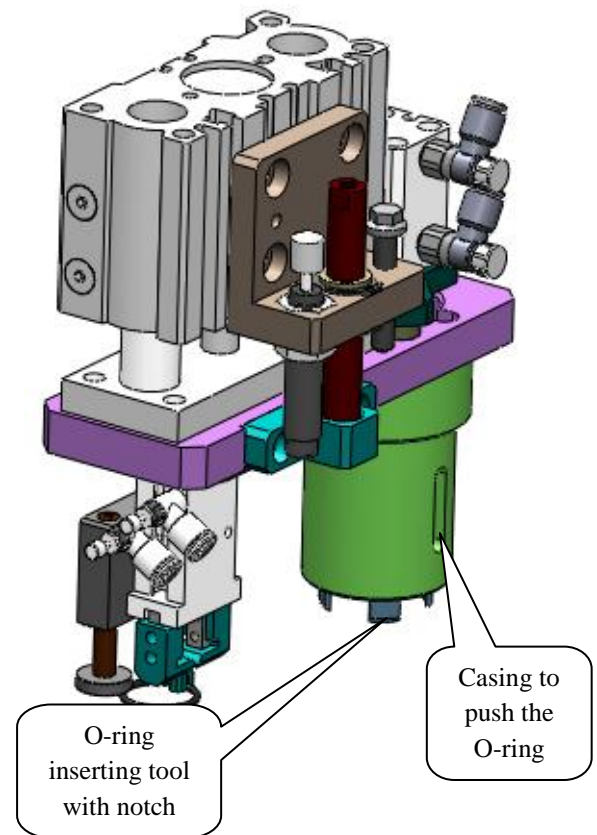

Fig 2.3

### 3. CONCLUSION

Thus we have found solution for the inserting of the O-ring in the pipe industry by automation. The movement of the actuators can be controlled by the valves that are controllers by microprocessors, PLC's or industrial computers. Sensors are used to get feedback of various operations.

By the use of this concept the O-ring insertion which has to be done with accuracy and involving skilled labor can be done at a much less time and without any labor increasing the productivity.

### REFERENCES

- [1] A.Granlund, M.H. Jackson. Managing Automation Development Projects: A Comparison of Industrial Needs and Existing Theoretical Support. *Advances in Sustainable & Competitive Manufacturing Systems*. 2013:761
- [2] Martinek et al., 2010 Martinek, R., Al-Wohaishi M., Zidek, J., Software based flexible measuring systems for analysis of digitally modulated systems, (2010). Brad, R, RoEduNet IEEE International Conference, Google Scholar.
- [3] Vlasios Tsiatsis, Stamatis Karnouskos, Jan Höller, David Boyle, Catherine Mulligan, *Internet of Things (Second edition)*, 2019, Chapter 11: Industrial Automation, Pages 249-256