

Canal Automation Using LabVIEW

Sarika S. Magdum¹, Swapnali S. Patil², Pradnya P. Shete³, Pravin B. Desai⁴

^{1,2,3}BE STUDENT'S , Dept. of Electronics and Telecommunication Engineering, Ashokrao Mane Group Of Institutions, Vathar Affiliated to Shivaji University, Hatkanangale, Kolhapur.

⁴Assistant Professor , Dept. of Electronics and Telecommunication Engineering, Ashokrao Mane Group Of Institutions, Vathar Affiliated to Shivaji University, Hatkanangale, Kolhapur.

Abstract – Automation of the canal plays a major role in the water transport system. It provides rapid water transfer with frequent changes, while allowing flexibility in operation. Using LabVIEW, this paper proposes a local, downstream, demand-oriented channel automation system. It deals with hardware devices that senses the amount of water available, calculates the amount of water discharge and operates actuators through a software control system based on LabVIEW to regulate the water flow. The module of LabVIEW software is used to automate process control, provide better accuracy and reduce costs. In the past, people had to shut down the gates of the canal. In large quantities, this process would take a lot of time and water wastage. In general, the overall water utilization efficiency of a manually operated system does not exceed about 40 %. It is expected that the overall efficiency of a system with some automation will increase by about 10 percent.

Key Words: ARM7 Processor, Motor Driver, LCD Display, Water Level Sensor.

1. INTRODUCTION

Automation of the canal plays an important role in the system of water transport. It provides rapid water transfer with frequent changes, while incorporating operational flexibility. This paper uses LabVIEW to propose a local, downstream, demand-oriented channel automation system. It deals with hardware devices that senses the amount of water available, calculates the amount of water discharge and operates actuators through a software control system based on LabVIEW to regulate water flow. The module of LabVIEW software is used to automate process control, provide better accuracy, and reduce costs.

In general, the overall water utilization efficiency of a manually operated system does not exceed about 40 %. The overall efficiency of a system with some automation is expected to increase by about 10 percent. This project is designed to automate canal water discharge by taking into account available water storage and water supply demand. Using Lab View software to enable reliable water distribution, this automation of water discharge at canals is implemented.

In the past, people needed to shut down the gates of the canal. In large quantities, this process would take a lot of time and water wastage. In general, the overall water utilization efficiency of a manually operated system does not exceed about 40 %. It is expected that the overall efficiency of a system with some automation will increase by about 10 percent.

2. PROPOSED WORK SYSTEM

2.1 BLOCK DIAGRAM

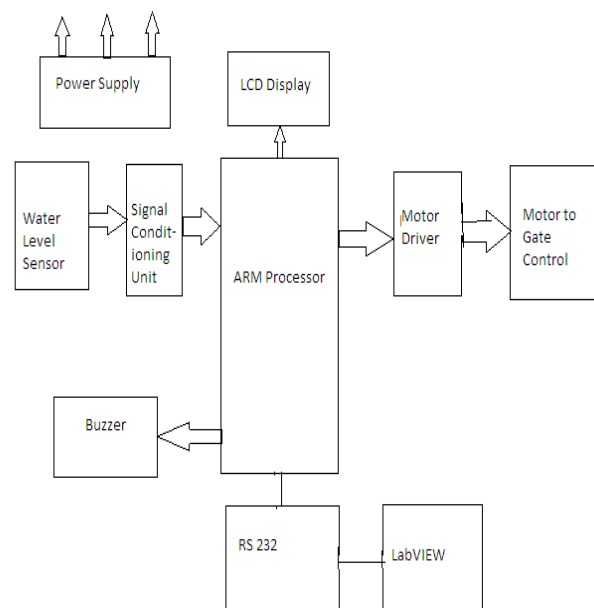

Fig 1. Block diagram of Canal Automation Using LabVIEW

2.2 PROPOSED WORK

The ARM7 microcontroller is the controller used here. The microcontroller is the core of this system, which gives all networks the order of suggestions received and sensitive factors processed by their respective programs. To meet the demand for order supply, the level water at the backwater storage of the channel is measured using potentiometer, first

of all the available water storage in the channel is taken into account. It has a high sensitivity and time to respond quickly. These signals are fed as input to the LabVIEW software set of arm7 controller tools after conditioning.

Two motors are used to control the flow of water through the canal gate. The engine used is the engine type L293D. The engine driver is connected to drive the engine behind the engine. The two engines are used for canal gates opening and closing. To open the motor of the gate, rotate in the direction of the clockwise direction and close the motor of the gate. The LCD display and ARM7 controller are supplied with power.

On the output side, the LCD display is used to display water level in the status of the canal and canal gate. Buzzer is also available for channel overflow indication on the output side. You can view and control the canal gate status through LabVIEW software. It is called MAX232 or Ethernet to connect the LabVIEW software and other serial interface circuitry.

2.3 FLOW CHART

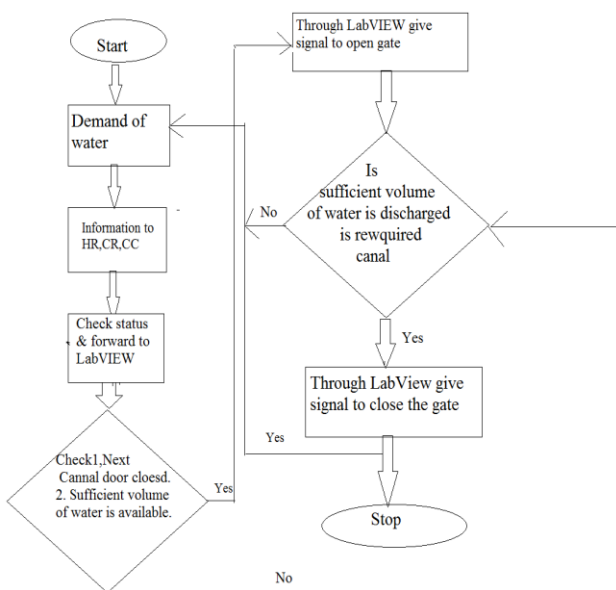

Fig2. Flow Chart

3. RESULT

3.1 PROPOSED MODEL

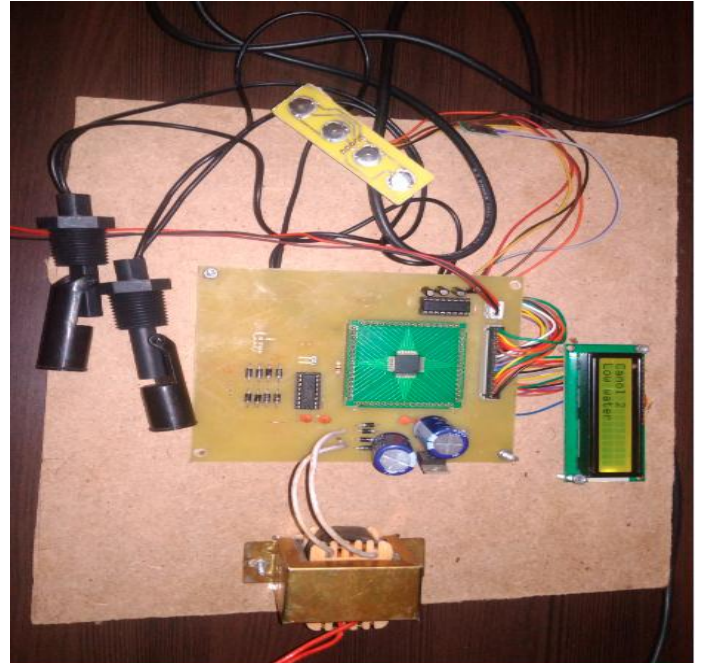
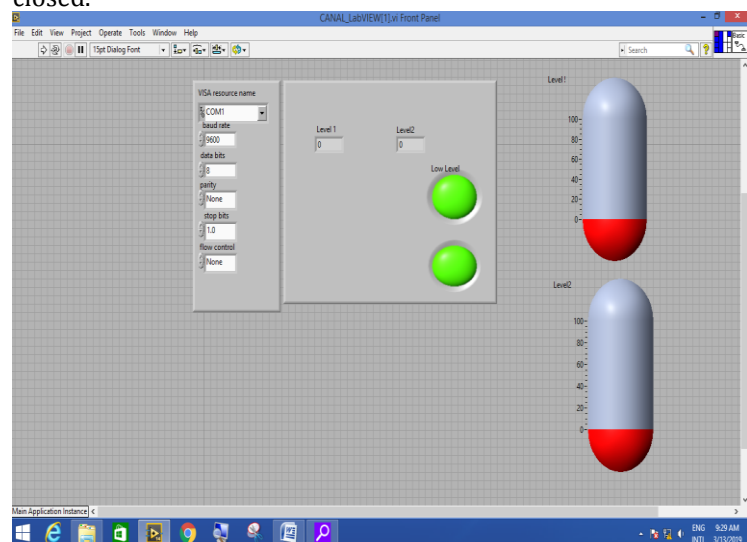
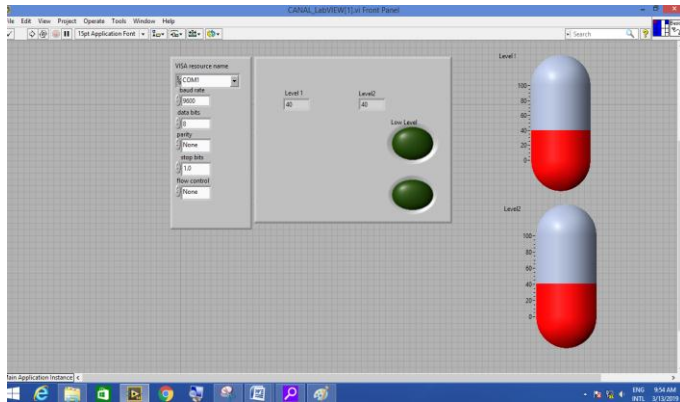

Fig3. Proposed Model

Condition 1: If the water level is higher than 10 percent, then the LED will go off, indicating that there is enough water available in the canal when gates will be closed.



Condition 2: If the water level is greater than 10 percent then LED will off and it indicates that there is sufficient amount of water available in canal at that time gates will be opened.



Condition 3: If the water level is greater than 10 percent then LED1 will off and it indicates that there is sufficient amount of water in canal A at that time gate A will be opened. If the water level is below 10 percent then LED2 ON and it indicates that there is a insufficient amount of water in canal B at that time gate B will be closed.

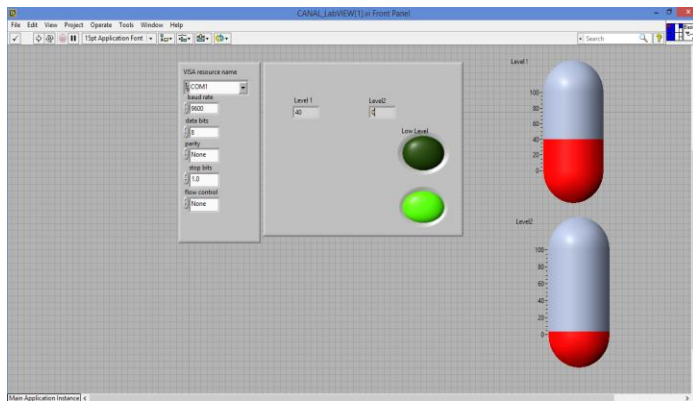

4. CONCLUSION

It atomizes process control, providing greater accuracy and cost reduction. It increases overall efficiency from 40% to 50%. It saves water wastage due to demand-oriented service.

5. REFERENCES

[1] Varawoot Vudhivanich¹ and Wich Sriwongsa², Development of a Canal Automation Model: A Laboratory Experiment”, Kasetsart J. (Nat. Sci.) 45: 353 - 365 (2011).

[2] Charles M. Burt, –District Canal Automation – CARDD, Proceedings of the Third National Irrigation Symposium. Phoenix, Arizona. ASAE Publication 04-90.Pp.495-500 [http://www.itrc.org/papers/cardd/ cardd.pdf](http://www.itrc.org/papers/cardd/cardd.pdf) ITRC Paper 90-.

[3] Canal Automation Publication No.238, Central Board of Irrigation and Power, New Delhi, November 1993.

[4] Shubhangi P. Bhat¹ and Prof. Sunil. R. Hirekhan (Department of Electronics and Telecommunication, Govt. College of Engineering, Aurangabad, Aurangabad, India), was developed “Canal automation using LabVIEW” project, in 2015.

[5] [http:// www.NI.com/support](http://www.NI.com/support)

[6][http:// www.NI.com/ask/](http://www.NI.com/ask/)

[7]<http://www.NI.com/info/>

[8]<http://www.NI.com/activate>.