

An Improvement of the Power Quality of Power Distribution System Using Modified iUPQC Controller

G SRINIVASARAO, M.TECH

ABSTRACT: This paper exhibits an enhanced controller for the double topology of the bound together power quality conditioner (iUPQC) developing its appropriateness in force quality pay, and in addition in micro grid Applications. By utilizing this controller, past the traditional UPQC power quality elements, including voltage Sag/swell, the iUPQC will likewise give receptive force backing to manage the heap transport voltage as well as the voltage at the network side Transport. At the end of the day, the iUPQC will function as a static synchronous compensator (STATCOM) at the lattice side, while giving likewise the traditional UPQC pay at the heap or micro grid Side. Trial results are given to check the new Usefulness of the hardware.

Index Terms: iUPQC, microgrids, power quality, Static synchronous compensator (STATCOM), unified Power quality conditioner (UPQC).

I. INTRODUCTION

Surely control hardware gadgets have brought about Extra ordinary innovative enhancements. Be that as it may, the expanding number of force hardware driven burdens utilized by and large as a part of the business has realized extraordinary force quality issues.

Interestingly, control gadgets driven loads by and large require perfect sinusoidal supply voltage so as to capacity appropriately, while they are the most capable ones for unusual symphonious streams level in the Dissemination framework. In this situation, gadgets that can alleviate these disadvantages have been Produced throughout the years. A portion of the arrangements include an adaptable compensator, known as the bound together power quality conditioner (UPQC) [1]–[7] and the static synchronous Compensator (STATCOM) [8]–[13].

The force circuit of an UPQC comprises of a blend of a shunt dynamic channel and an arrangement dynamic Channel associated in a consecutive setup. This blend permits the concurrent remuneration of the heap current and the supply voltage, so that the repaid current drawn from the framework and the repaid supply voltage conveyed to the heap are kept adjusted And sinusoidal. The double topology of the UPQC, i.e., the iUPQC, was introduced in [14]–[19], where the shunt dynamic channel carries on as an air conditioner voltage source and the arrangement one as an air conditioner current source, both at the basic Recurrence. This is a key point to better outline the control picks up, and in addition to streamline the LCL channel of the force

converters, which permits enhancing fundamentally the general execution of the Compensator [20].

The STATCOM has been utilized generally as a part of transmission net attempts to direct the voltage by Method for element receptive force remuneration. These days, the STATCOM is to a great extent utilized for voltage direction [9], while the UPQC and the iUPQC have been chosen as answer for more Particular applications [21]. In addition, these last ones are utilized just as a part of specific cases, where their generally high expenses are legitimized by the force quality change it can give, which would be unfeasible By utilizing customary arrangements. By joining the additional usefulness like a STATCOM in the iUPQC gadget, a more extensive situation of utilization scan be come to, especially if there should be an occurrence of disseminated era in shrewd lattices and as the Coupling gadget in network tied microgrids.

In [16], the execution of the iUPQC and the UPQC Was looked at when functioning as UPQCs. The fundamental distinction between these compensators is the kind of source imitated by the arrangement and Shunt power converters. In the UPQC approach, the arrangement converter is controlled as a no sinusoidal voltage source and the shunt one as a no sinusoidal Current source. Subsequently, progressively, the UPQC controller needs to decide and orchestrate precisely the Constant voltage and current to be adjusted. Then again, in the iUPQC approach, the arrangement converter carries on as a controlled sinusoidal current source and the shunt converter as a controlled Sinusoidal voltage source. This implies it is not important to decide the consonant voltage and current to be adjusted, since the symphonious voltages show up actually over the arrangement current source and the consonant streams stream normally into the shunt Voltage source.

In genuine force converters, as the exchanging recurrence in-wrinkles, the force rate capacity is Decreased. Along these lines, the iUPQC offers better arrangements if contrasted and the UPQC if there should arise an occurrence of high-power applications, since the iUPQC repaying references are immaculate sinusoidal waveforms at the key recurrence. Additionally, the UPQC has higher changing misfortunes because of its higher exchanging recurrence.

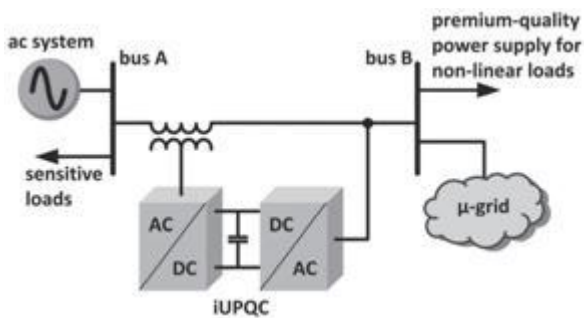

Fig. 1 Example of applicability of iUPQC

This paper proposes an enhanced controller, which grows the iUPQC functionalities. This enhanced adaptation of iUPQC controller incorporates all functionalities of those past ones, including the voltage direction at the heap side transport, and now giving additionally voltage direction at the framework side transport, similar to a STATCOM to the lattice. Exploratory results are given to accept the new controller outline.

This paper is sorted out in five areas. After this presentation, in Section II, the iUPQC appropriateness is clarified, and in addition the novel component of the proposed controller. Area III displays the proposed controller and an investigation of the force stream in consistent state. At last, Sections IV and V give the trial comes about and the conclusions, individually.

II. EQUIPMENT APPLICABILITY:

Keeping in mind the end goal to elucidate the materialness of the enhanced iUPQC controller, Fig. 1 portrays an electrical framework with two transports in spotlight, i.e., transport An and transport B. Transport A will be a basic transport of the force framework that supplies touchy loads and serves as purpose of coupling of a micro grid. Transport B is a transport of the micro grid, where nonlinear burdens are associated, which requires premium-quality force supply. The voltages at transports An and B must be managed, with a specific end goal to legitimately supply the touchy burdens and the

- ☐ energy and power flow control between the grid and the micro grid (imposed by a tertiary control layer for the micro grid);
- ☐ reactive power support at bus A of the power system;
- ☐ voltage/frequency support at bus B of the micro grid;
- ☐ harmonic voltage and current isolation between bus A and bus B (simultaneous grid-voltage and load-current active-filtering capability);

Voltage and current imbalance compensation. The functionalities (d)–(f) beforehand recorded were broadly clarified and checked through reproductions and test investigation [14]–[18], though the usefulness © Involves the first commitment of the present work. Fig. 2 delineates,

in subtle element, the associations and estimations of the iUPQC between transport an and transport B.

As indicated by the customary iUPQC controller, the shunt converter forces a controlled sinusoidal voltage at transport B, which relates to the previously mentioned usefulness (d). Subsequently, the shunt converter has no further level of flexibility as far as remunerating dynamic or responsive force variables to grow its usefulness. Then again, the arrangement converter of an ordinary iUPQC utilizes just a dynamic force control variable p, keeping in mind the end goal to orchestrate a principal sinusoidal current drawn from transport A, relating to the dynamic force requested by transport B. In the event that the dc connection of the iUPQC has no substantial vitality stockpiling framework or even no vitality source, the control variable p likewise serves as an extra dynamic force reference to the arrangement converter to keep the vitality inside the dc connection of the iUPQC adjusted. For this situation, the misfortunes in the iUPQC and the dynamic influence supplied by the shunt converter must be immediately repaid as an extra dynamic influence infused by the arrangement converter into the transport B. TheiUPQC can serve as:

- a) smart|| circuit breaker and as b) power flow controller between the grid and the microgrid only if the compensating active- and reactive-power references of the series converter can be set arbitrarily. In this case, it is necessary to provide an energy source (or large energy storage) associated to the dc link of the iUPQC.

The last level of opportunity is spoken to by a receptive force control variable q for the arrangement converter of the iUPQC. Along these lines, the iUPQC will give receptive force remuneration like a STATCOM to the transport an of the network. As it will be affirmed, this usefulness can be included into the controller without debasing all different functionalities of the iUPQC.

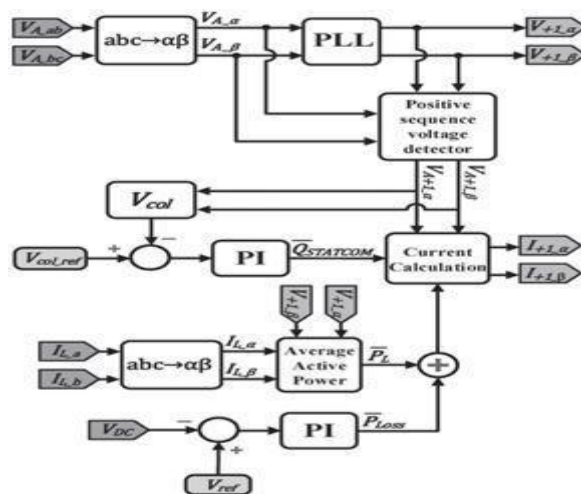

Fig. 2. Novel iUPQC controller.

The last level of flexibility is spoken to by a receptive force control variable q for the arrangement converter of the

iUPQC. Along these lines, the iUPQC will give responsive force remuneration like a STATCOM to the transport An of the lattice. As it will be affirmed, this usefulness can be included into the controller without corrupting all different functionalities of the iUPQC.

III. IMPROVED IUPQC CONTROLLER A. Main Controller:

Fig. 2 delineates the iUPQC equipment and the deliberate units of a three-stage three-wire framework that are utilized as a part of the controller. Fig. 3 demonstrates the proposed controller. The controller inputs are the voltages at transports An and B, the current requested by transport B (iL), and the voltage vDC of the normal dc join. The yields are the shunt-voltage reference and the arrangement current reference to the beat width regulation (PWM) controllers. The voltage and current PWM controllers can be as basic as those utilized in [18], or be enhanced further to better manage voltage and current lopsidedness and sounds [23]–[28].

Initially, the streamlined Clark change is connected to the deliberate variables. As case of this change, the matrix voltage in the $\alpha\beta$ -reference edge can be figured as

$$\begin{bmatrix} V_{A_alpha} \\ V_{A_beta} \end{bmatrix} = \begin{bmatrix} 1 & 1/2 \\ 0 & \sqrt{3}/2 \end{bmatrix} \begin{bmatrix} V_{A_ab} \\ V_{A_bc} \end{bmatrix} \tag{1}$$

The shunt converter forces the voltage at transport B. In this way, it is important to integrate sinusoidal voltages with ostensible plentifulness and recurrence. Subsequently, the signs sent to the PWM controller are the stage bolted circle (PLL) yields with plentifulness equivalent to 1 p.u. There are numerous conceivable PLL calculations, which could be utilized as a part of this case, as confirmed in [29]–[33]. In the first iUPQC approach as displayed in [14], the shunt-converter voltage reference can be the PLL yields or the crucial positive-grouping part V_{A+1} of the framework voltage (transport An in Fig. 2). The utilization of V_{A+1} in the controller is valuable to minimize the flowing force through the arrangement and shunt converters, under ordinary operation, while the adequacy of the framework voltage is inside a worthy scope of size. Be that as it may, this is not the situation here, in the altered iUPQC controller, since now the network voltage will be additionally managed by the adjusted iUPQC. As it were, both transports will be directed freely to track their reference values. The arrangement converter blends the current drawn from the matrix (transport A). In the first approach of iUPQC, this current is computed through the normal dynamic force required by the heaps PL in addition to the force PLoss. The heap dynamic force can be assessed by

$$V_{col} = \sqrt{V_{A+1_alpha}^2 + V_{A+1_beta}^2} \tag{3}$$

Where iL_α, iL_β are the heap streams, and $V_{+1_alpha}, V_{+1_beta}$ are the voltage references for the shunt converter. A low-pass channel is utilized to acquire the normal dynamic force (PL).

The misfortunes in the influence converters and the circling influence to give vitality parity inside the iUPQC are figured in a roundabout way from the estimation of the dc-join voltage. At the end of the day, the force signal PLoss is dictated by a proportional– indispensable (PI) controller (PI obstruct in Fig. 3), by contrasting the deliberate dc voltage VDC and its reference esteem.

The extra control circle to give voltage direction like a STATCOM at the network transport is spoken to by the control signal STATCOM in Fig. 3. This control sign is acquired through aPI controller, in which the information variable is the mistake between the reference esteem and the genuine total voltage of the framework transport, given by

$$V_{col} = \sqrt{V_{A+1_alpha}^2 + V_{A+1_beta}^2} \tag{3}$$

The sum of the power signals PL and P Loss composes the active-power control variable for the series converter of the iUPQC(p) described in Section II. Likewise, STATCOM is the reactive power control variable q . Thus, the current references $i_{+1\alpha}$ and $i_{+1\beta}$ of the series converter are determined by

$$\begin{bmatrix} i_{+1_alpha} \\ i_{+1_beta} \end{bmatrix} = \frac{1}{V_{A+1_alpha}^2 + V_{A+1_beta}^2} \begin{bmatrix} V_{A+1_alpha} & V_{A+1_beta} \\ V_{A+1_beta} & -V_{A+1_alpha} \end{bmatrix} \times \begin{bmatrix} P_L + P_{Loss} \\ Q_{STATCOM} \end{bmatrix} \tag{4}$$

B. Power Flow in Steady State:

The accompanying strategy, in light of the normal force stream, is helpful for assessing the force appraisals of the iUPQC converters. For joined series– shunt power conditioners, for example, the UPQC and the iUPQC, just the voltage hang/swell unsettling influence and the force component (PF) pay of the heap create a flowing normal force through the force conditioners [34], [35]. As indicated by Fig. 4, the compensation of a voltage hang/swell unsettling influence at transport B causes a positive sequence voltage at the coupling transformer ($V_{series_} = 0$), since $V_A = V_B$. Besides, V_{series} and i_{PB} in the transformer prompts a coursing dynamic power P inner in the iUPQC. Moreover, the pay of the heap PF builds the current supplied by the shunt converter. The following analysis is substantial for iUPQC acting like a conventional UPQC or including the additional pay like a STATCOM.

To begin with, the coursing force will be ascertained when the iUPQC is working simply like a traditional UPQC. Thereafter, the conditions will incorporate the STATCOM usefulness to the lattice transport A. In both cases, it will be expected that the iUPQC controller can constrain the shunt converter of the iUPQC to create basic voltage

dependably in stage with the framework voltage at transport A. For effortlessness, the misfortunes in the iUPQC will be ignored. For the main case, the accompanying normal forces in unflinching state can be resolved:

$$\bar{S}_A = \bar{P}_B \tag{5}$$

$$\bar{Q}_{shunt} = -\bar{Q}_B \tag{6}$$

$$\bar{Q}_{series} = \bar{Q}_A = 0 \text{ var} \tag{7}$$

$$\bar{P}_{series} = \bar{P}_{shunt} \tag{8}$$

Where SA and QA are the evident and receptive force infused in the transport A; PB and QB are the dynamic and responsive force infused in the transport B; P shunt and Q shunt are the dynamic and responsive force depleted by the shunt converter; P series and Q series are the dynamic and responsive force supplied by the arrangement converter, separately.

Conditions (5) and (8) are gotten from the imperative of keeping unitary the PF at transport A. For this situation, the present going through the arrangement converter is capable just to supply the heap dynamic power, that is, it is in stage (or counter stage) with the voltages VA and VB. Along these lines, (7) can be expressed. Subsequently, the intelligence of the force stream is guaranteed through (8).

In the event that a voltage droop or swell happens, P series and P shunt won't be zero, and in this way, an internal circle current (inner) will show up. The arrangement and shunt converters and the previously mentioned dynamic force (P inner) stream inside the equipment. It is advantageous to characterize the accompanying droop/swell component.

Considering VN as the ostensible voltage

$$k_{sag/swell} = \frac{|V_A|}{|V_N|} = \frac{V_A}{V_N} \tag{9}$$

From (5) and considering that the voltage at bus B is kept regulated, i.e., VB = VN, it follows that

$$\sqrt{3} \cdot k_{sag/swell} \cdot V_N \cdot i_S = \sqrt{3} \cdot V_N \cdot i_{P_B}$$

$$i_S = \frac{i_{P_B}}{k_{sag/swell}} = i_{P_B} + i_{inner} \tag{10}$$

$$i_{inner} = \left| i_{P_B} \left(\frac{1}{K_{sag/swell} - 1} \right) \right| \tag{11}$$

The circulating power is given by

$$\bar{P}_{inner} = \bar{P}_{series} = \bar{P}_{shunt} = 3(V_B - V_A)(i_{P_B} + i_{inner}) \tag{12}$$

From (11) and (12), it follows that

$$\bar{P}_{inner} = 3(V_N - V_A) \left(\frac{P_B}{3V_N} \frac{1}{k_{sag/swell}} \right) \tag{13}$$

$$\bar{P}_{inner} = \bar{P}_{series} = \bar{P}_{shunt} = \frac{1 - K_{sag/swell}}{k_{sag/swell}} \bar{P}_B \tag{14}$$

In this manner, (14) exhibits that P inner relies on the active power of the heap and the droop/swell voltage aggravation. So as to check the impact on the force rate of the arrangement and shunt converters, a

Full load framework SB with PF extending from 0 to 1 was considered. It was additionally considered the hang/swell voltage unsettling influence at transport A going k sag/swell from 0.5 to 1.5. Along these lines the force rating of the arrangement and shunt converters are gotten through (6)-(8) and (14). Fig. 5 portrays the clear force of the arrangement and shunt power converters. In these figures, the k sag/swell-hub and the PF-hub are utilized to assess the force stream in the series and shunt power converters as indicated by the list/swell voltage unsettling influence and the heap power utilization, separately. The force stream in the arrangement converter demonstrates that a high power is required if there should be an occurrence of list voltage aggravation with high dynamic force load utilization. In this circumstance, an increased P inner arises and high appraised power converters are important to guarantee the unsettling influence remuneration. Also, if there should be an occurrence of compensating sag/swell voltage unsettling influence with high receptive force load utilization, just the shunt converter has high power demand, since P inner diminishes. It is imperative to highlight that, for each PF esteem, the sufficiency of the clear power is the same for capacitive or inductive burdens. At the end of the day, Fig. 5 is the same for QB capacitive or inductive. In the event that the iUPQC performs all unique UPQC functionalities together with the STATCOM functionality, the voltage at bus A is also regulated with the same phase and magnitude, that is, VA = VB = VN, and then, the positive sequence of the voltage at the coupling transformer is zero (Vseries = 0). Thus, in steady state, the power flow is determined by

$$\bar{S}_A = \bar{P}_B + \bar{Q}_{STATCOM} \tag{15}$$

$$\bar{Q}_{STATCOM} + \bar{Q}_{series} = \bar{Q}_{shunt} + \bar{Q}_B \tag{16}$$

$$\bar{Q}_{series} = 0 \text{ var} \tag{17}$$

$$\bar{P}_{series} = \bar{P}_{inner} = 0 \text{ W} \tag{18}$$

Where STATCOM is the receptive force that gives voltage control at transport A. In a perfect world, the STATCOM usefulness mitigates the inward circle dynamic force stream (P inner), and the force stream in the arrangement converter is zero. Thusly, if the arrangement converter is

legitimately planned alongside the coupling transformer to integrate the controlled streams $I+1_\alpha$ and $I+1_\beta$, as demonstrated in Fig. 3, then a lower power converter can be utilized. Conflictingly, the shunt converter still needs to give the full receptive force of the heap furthermore to deplete the responsive force infused by the

Arrangement converter to direct the voltage at transport A

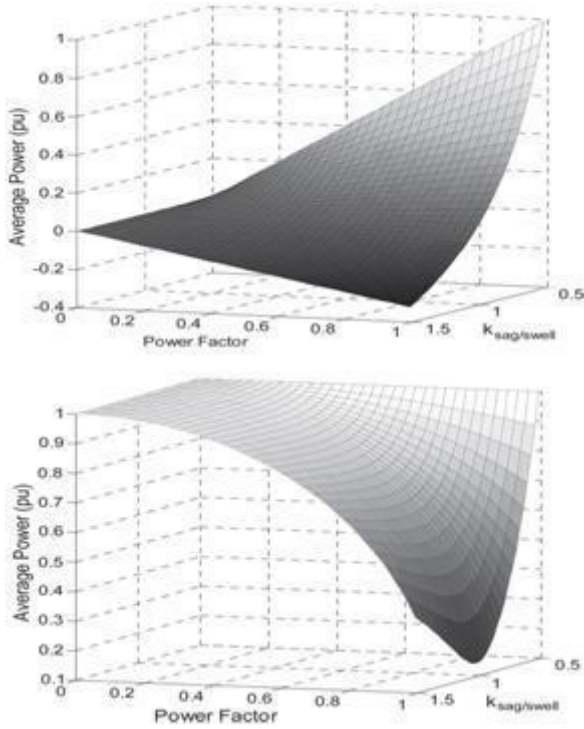

Fig. 5. Apparent power of the series and shunt Converters respectively.

TABLE I: IUPQC PROTOTYPE PARAMETERS

Parameter	Value
Voltage	220 V rms
Grid frequency	60 Hz
Power rate	5 kVA
DC-link voltage	450 V dc
DC-link capacitors	$C = 9400 \mu\text{F}$
Shunt converter passive filter	$L = 750 \mu\text{H}$
	$R = 3.7 \Omega$
	$C = 20.0 \mu\text{F}$
Series converter passive filter	$L = 1.0 \text{ mH}$
	$R = 7.5 \Omega$
	$C = 20.0 \mu\text{F}$
Sampling frequency	19440 Hz
Switching frequency	9720 Hz
PI controller (P_{loss})	$K_p = 4.0$
	$K_i = 250.0$
PI controller ($Q_{STATCOM}$)	$K_p = 0.5$
	$K_i = 50.0$

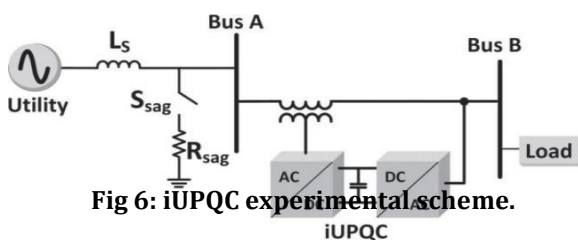

Fig 6: iUPQC experimental scheme.

IV. EXPERIMENTAL RESULTS:

The enhanced iUPQC controller, as appeared in Fig. 3, was checked in a 5-kVA model, whose parameters are displayed in Table I. The controller was installed in a Settled point advanced sign processor (TMS320F2812). Keeping in mind the end goal to confirm all the force quality issues portrayed in this Paper the iUPQC was associated with a network with a voltage list framework, as delineated in Fig. 6. The voltage droop framework was made by an inductor (L_s), a resistor (R_{Sag}), and a breaker (S_{Sag}). To bring about voltage droop at transport A, S_{Sag} is closed. At to begin with, the source voltage direction was tried with no load connected to transport B. For this situation, the iUPQC carries on as a STATCOM and the breaker S_{Sag} is shut to bring about the voltage sag. To confirm the matrix voltage direction (see Fig. 7), the control of the STATCOM variable is empowered to make (4) at instant = 0 s. In this exploratory case, $L_s = 10 \text{ mH}$, and $R_{\text{Sag}} = 7.5 \Omega$. Before the STATCOM variable is empowered, just the dclink and the voltage at transport B are managed, and there is a voltage list at transport an as appeared in Fig. 7. After $t = 0\text{s}$, the iUPQC starts to draw receptive current from transport an expanding the voltage until its reference esteem. As indicated in Fig. 7, the heap voltage at transport B is kept up managed amid constantly, and the network voltage regulation of transport A has a quick reaction.

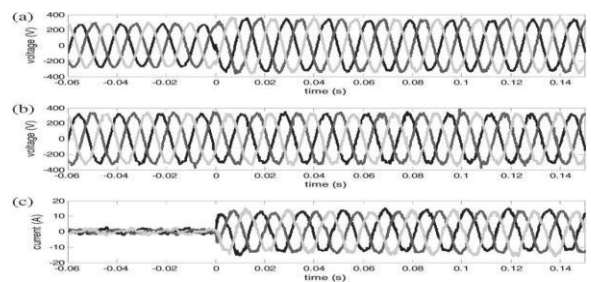

Fig. 7 iUPQC response at no load condition: (a) grid voltages V_A , (b) load voltages V_B , and (c) grid currents

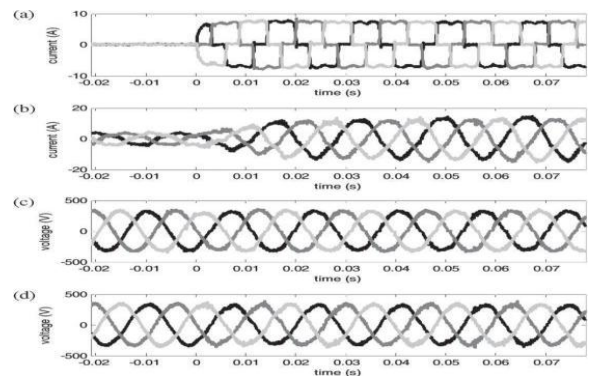

Fig. 8. iUPQC transitory response during the connection of a three-phase diode rectifier: (a) load currents, (b) grid currents, (c) load voltages and (d) grid voltages.

Next, the experimental case was carried out to verify the iUPQC performance during the connection of a nonlinear load with the iUPQC already in operation. The load is a three-phase diode rectifier with a series RL load at the dc link ($R = 45 \Omega$ and $L = 22 \text{ mH}$), and the circuit breaker S_{sag} is permanently closed, with $L_s = 10 \text{ mH}$ and a $R_{sag} = 15 \Omega$. In this way, the voltage-sag disturbance is increased due to the load connection. In Fig. 8, it is possible to verify that the iUPQC is able to regulate the voltages at both sides of the iUPQC, at the same time. Indeed, even after the heap association, at $t=0 \text{ s}$, the voltages are still controlled, and the streams drawn from transport An are practically sinusoidal. Thus, the iUPQC can play out all the force quality pay, as said some time recently, including the framework voltage control. The same method was performed with the association of a two-stage diode rectifier, so as to better confirm the alleviation of force quality issues.

The diode rectifier has the same dc load ($R = 45 \Omega$ and $L = 22 \text{ mH}$) and the same voltage hang ($L_s = 10 \text{ mH}$ and $R_{msag} = 15 \Omega$). Fig. 9 delineates the brief reaction of the heap association. Regardless of the two-stage load streams, after the heap association at $t = 0 \text{ s}$, the three-stage current depleted from the lattice has a decreased uneven part. For this situation, the uneven current of the heap could be supplied by the shunt converter, and the voltage at the transport B could be precisely the voltage combined by the shunt converter. Consequently, without channel inductor, there would be no unbalance voltage drop in it and the voltage at transport B would stay adjusted.

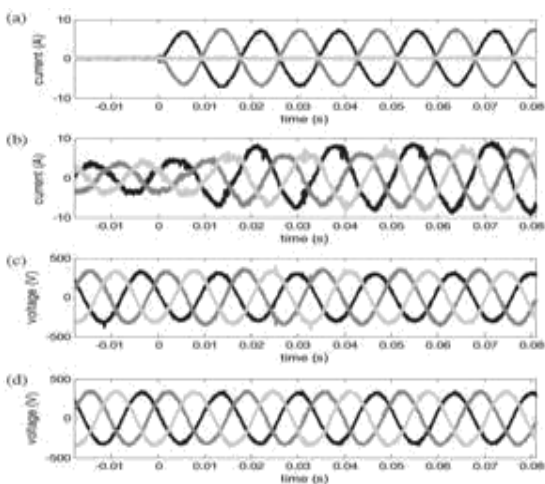

Fig. 9. iUPQC transitory response during the Connection of a two-phase diode rectifier: (a) load currents, (b) source currents, (c) load voltages and Source voltages

V. CONCLUSION:

In this paper, presented all the force quality pay components of an ordinary UPQC or an iUPQC, this enhanced controller additionally imitates a STATCOM to the network transport. This new element upgrades the materialness of the iUPQC and gives new arrangements in future situations including brilliant networks and micro grids, including circulated era and vitality stockpiling frameworks to better manage the inborn variability of

renewable assets, for example, sunlight based and wind power. Moreover, the enhanced iUPQC controller may legitimize the expenses and advances the iUPQC appropriateness in force quality issues of basic frameworks, where it is important an iUPQC or a STATCOM, as well as both, at the same time. Notwithstanding the expansion of one more power quality pay include, the network voltage control lessens the internal circle coursing power inside the iUPQC, which would permit lower power rating for the arrangement converter. The test comes about checked the enhanced iUPQC objectives. The framework voltage direction was accomplished with no heap, and in addition when supplying a three-stage nonlinear burden. These outcomes have shown a reasonable execution of voltage direction at both sides of the iUPQC.

REFERENCES:

- [1] K. Karanki, G. Geddada, M. K. Mishra, and B. K. Kumar, A modified three-phase four-wire UPQC topology with reduced DC-link voltage rating, || IEEE Trans. Ind. Electron., vol. 60, no. 9, pp. 3555–3566, Sep. 2013.
- [2] V. Khadkikar and A. Chandra, —A new control philosophy for a unified power quality conditioner (UPQC) to coordinate load-reactive power demand between shunt and series inverters, || IEEE Trans. Power Del., vol. 23, no. 4, pp. 2522–2534, Oct. 2008.
- [3] K. H. Kwan, P. L. So, and Y. C. Chu, —An output regulation-based uni-fied power quality conditioner with Kalman filters, || IEEE Trans. Ind. Electron., vol. 59, no. 11, pp. 4248–4262, Nov. 2012.
- [4] A. Mokhtatpour and H. A. Shayanfar, —Power quality compensation as well as power flow control using of unified power quality conditioner, || in Proc. APPEEC, 2011, pp. 1–4.
- [5] J. A. Munoz et al., —Design of a discrete-time linear control strategy for a multicell UPQC, || IEEE Trans. Ind. Electron., vol. 59, no. 10, pp. 3797–3807, Oct. 2012.
- [6] V. Khadkikar and A. Chandra, —UPQC-S: A novel concept of simulta-neous voltage sag/swell and load reactive power compensations utilizing series inverter of UPQC, || IEEE Trans. Power Electron., vol. 26, no. 9, pp. 2414–2425, Sep. 2011.
- [7] V. Khadkikar, —Enhancing electric power quality using UPQC: A comprehensive overview, || IEEE Trans. Power Electron., vol. 27, no. 5, pp. 2284–2297, May 2012.
- [8] L. G. B. Rolim, —Custom power interfaces for renewable energy sources, || in Proc. IEEE ISIE, 2007, pp. 2673–2678.
- [9] N. Voraphonpiput and S. Chatratana, —STATCOM analysis and con-troller design for power system voltage regulation, || in Proc. IEEE/PESTransmiss. Distrib. Conf. Exhib.—Asia Pac., 2005, pp. 1–6.
- [10] J. Sanchez-Gasca, N. W. Miller, E. V. Larsen, A. Edris, and A. Bradshaw, —Potential benefits of STATCOM

application to improve generation station performance,|| in Proc. IEEE/PES Transmiss. Distrib.Conf. Expo., 2001, vol. 2, pp. 1123–1128. topology with reduced DC-link voltage rating,|| IEEE Trans. Ind. Electron., vol. 60, no. 9, pp. 3555–3566, Sep. 2013.

[9] V. Khadkikar and A. Chandra, –A new control philosophy for a unified power quality conditioner (UPQC) to coordinate load-reactive power demand between shunt and series inverters,|| IEEE Trans. Power Del., vol. 23, no. 4, pp. 2522–2534, Oct. 2008.

[10] K. H. Kwan, P. L. So, and Y. C. Chu, –An output regulation-based uni-fied power quality conditioner with Kalman filters,|| IEEE Trans. Ind.Electron., vol.59, no. 11, pp. 4248–4262, Nov. 2012.

[11] A. Mokhtatpour and H. A. Shayanfar, –Power quality compensation as well as power flow control using of unified power quality conditioner,|| in Proc. APPEEC, 2011, pp. 1–4.

Author Details



G. Srinivasarao

Associate Professor, Department of Electrical and Electronics Engineering, MITK, Khammam, T.S - 507163, India.