

## GSM Based Home Automation

Sudarshan Madhavi<sup>1</sup>, Manisha Kumaanache<sup>2</sup>, Nilesh Madhavi<sup>3</sup>, Prof. Dhanashri Bhopatrao<sup>4</sup>

<sup>1,2,3</sup>Student, Dept. of Computer Engineering, L.E.S. G.V.Acharya Institute of Engineering and Technology, Shelu, Maharashtra, India

<sup>4</sup>Asst. Professor, Dept. of Computer Engineering, L.E.S. G.V.Acharya Institute of Engineering and Technology, Shelu, Maharashtra, India

\*\*\*

**Abstract** - In the Extant System Bluetooth and Wi-Fi for the home automation system which has certain limitation like range within 100 meters for Bluetooth and Wi-Fi also have range limitation based on router range, this system has certain drawbacks like short range distance, which cannot cover whole home circumference. Bluetooth has line-of-side problem. The intent of the GSM System is to develop an electronic application which uses SMS Mobile technology that keeps control of different electronics devices. As we have the new concept has been thought to manage them remotely by using a GSM, which enables the user remotely control switching off appliances. By simply sending SMS to the modem at the remote place, the devices can be turned ON/OFF and the status of the device can be sent to the registered mobile number programmed in the microcontroller.

**Key Words:** GSM(Global System For Mobile Communication ); SMS (Short Message Service), Home Automation.

### 1. INTRODUCTION

In modernistic years, there has been a growing interest among consumers in the smart home concept. Smart homes comprise multiple, connected devices such as home entertainment consoles, security systems, lighting, access control systems and surveillance. Intelligent home automation system is integrated into smart homes to provide comfort, convenience, and security to home owners. Home automation system impersonate and reports the status of the connected devices in an intuitive, user-friendly interface allowing the user to interact and control various devices with the touch of a few buttons. Some of the major communication technologies used by today's home automation system include Bluetooth, and Wireless LAN (Wi-Fi), and Global System for Mobile Communication (GSM). The proposed home automation system allows user to switch ON and OFF the lights, fans etc. This system is controlled using GSM module From any part of the world. The concept behind this is to receive the sent message string from mobile and then processing it to perform the desired function. This is most useful for people living alone since it allows them to remotely monitor their appliances.

### 2. PROPOSED SYSTEM

The proposed system consists of the GSM Based Home Automation System to develop an electronic application which uses SMS technology that keeps control of different electronics devices. We are having the new logic to operate them remotely by using GSM, by using this technology the user can remotely operate home appliances. By simply sending SMS to the GSM modem at the remote place, the devices can be turned ON/OFF and the status of the device can be sent to the registered mobile number programmed in the microcontroller.

### 3. COMPONENTS

#### 3.1 GSM Module



The GSM stands for GLOBAL SYSTEM for MOBILE COMMUNICATION. GSM module is a chip or circuit that is used to establish communication between a mobile device and a GSM system.

SIM800A is a complete Quad-band GSM/GPRS solution in a SMT type which can be embedded in the customer applications. This module holds Quad-band 850/900/1800/1900MHz, it can transmit Voice, SMS and data information with low power consumption. It is having tiny size of 24\*24\*3 mm, it can fit into slim and compact demands of customer design. The module consists of Embedded AT, it allows total cost savings and fast time-to-market for customer applications.

### 3.2 Arduino Board



The Arduino Uno board is a microcontroller based on the ATmega328. It has 14 digital input/output pins in which 6 can be used as PWM outputs, a 16 MHz ceramic resonator, an ICSP header, a USB connection, 6 analog inputs, a power jack and a reset button.

### 3.3 Relay



A relay is an electromagnetic device managed by a comparably small electric current that can turn on or off a much larger electric current. A relay has NO and NC states. When a relay is empowered it switches from NO to NC or from NC to NO whatever its previous state be.

### 4. SYSTEM ARCHITECTURE

The working of this project is very easy, a message is sent from the cell phone which has a command #A.FAN ON. After receiving the #A.FAN ON, GSM module sends it to the microcontroller. The microcontroller has a code saved in it, reads and interpret the message and accordingly sends a signal to relays to either ON or OFF the appliances as per the command received in the text message. Similar operation can be performed on each appliance connected to the GSM module which are connected to Relay.

### 5. CONCLUSIONS

It can be concluded that GSM BASED HOME AUTOMATION SYSTEM USING ARDUINO is successful. This automation system consists of an Arduino-Uno

board, a GSM Module, a GSM based phone, power sockets and home appliances. The system is cost effective and also a user friendly. Also, it can be concluded that the objectives of this project have been successfully met and they are as follows:

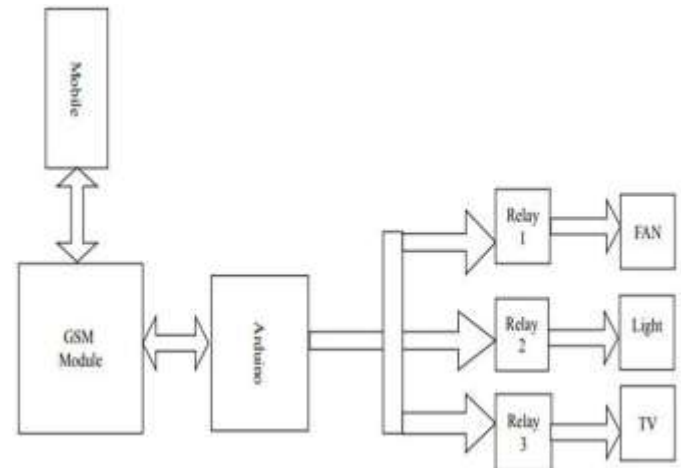

The home automation system is controlled by GSM based phone and it is constructed wirelessly. The Designed system is user friendly and a safe system to control home appliances, system is very helpful for elder and handicapped people. This system makes it possible for users to assured that their belongings are secure and that the FAN and other electrical appliances was not left running when they left the house. The design of this system is very simple for user to interact with system. This system can be used by people having the knowledge about the SMS.

### ACKNOWLEDGEMENT

We are very grateful to our project guide Prof. Dhanashri Bhopatrao who always supported and guided us. We express our immense pleasure and thankfulness to all faculty members of the Department of Computer Engineering of G. V. Acharya Institute of Engineering and Technology.

### REFERENCES

- [1] "Microcontroller Based Home Security System with GSM Technology" Raqibull Hasan, Mohammad Khan, Israt Jahan Rumpa Department of Electrical and Electronic Engineering, Prime Asia University, Dhaka, Bangladesh Open Journal of Safety Science and Technology, 2015.
- [2] "Design of an Intelligent Voice Controlled Home Automation System" Sonali Sen, Shamik Chakrabarty, Ankita Bhaumik Department of Computer Science St. Xavier's College, Kolkata international Journal of

Computer Applications (0975 – 8887) Volume 121 – No.15, July 2015.

- [3] “Home Automation Systems” - A Study Angel Deborah S Prof., CSE, SSN College of Engineering, Anna University, Chennai. International Journal of Computer Applications (0975 – 8887)Volume 116 – No. 11, April 2015.
- [4] “Cost Effective Voice Controlled Home Automation Using IoT” Abdul Aziz Md, K Harshasri, K Shanmukharao Lecturer in CSE Department, RGUKT, AP IIIT, E4 Student, CSE, RGUKT, AP IIIT, CSE, RGUKT, AP IIITInternational Journal of Engineering Research in Computer Science and Engineering (IJERCSE) Vo 14, Issue 3, March 2017.
- [5] “Home Automation System Using Android Application” Saptarshi Bhowmik, Sudipa Biswas, Karan Vishwakarma, Department of Computer Science Jadavpur University IBM India Research Associate ESL Technologies Research Associate ESL Technologies TCS, India International Journal of Scientific and Research Publications, Volume 6, Issue 12, December2016.
- [6] “Android Based Home Automation System Using Bluetooth & Voice Command” Bhavik Pandya, Nilesh Jain International Research Journal of Engineering and Technology (IRJET) Volume: 03 Issue: 03 | Mar-2016.