

Vehicle Accident Detection System using GSM and GPS

S.B. Pawar¹, Digvijay Mahamulkar², Laxmikant Somwanshi³

¹Assistant Professor, Dept. of ETC, Sinhgad Academy of Engineering, Pune, India.

^{2,3}B.E.Student, Dept. of ETC, Sinhgad Academy of Engineering, Pune, India.

Abstract - With the advent of science and technology in every walk of life the significance of vehicle safety has increased and the main priority is being given to decrease the accident recognition time when an accident occurs, so that the wounded lives can be attended in lesser time by the rescue team. The Microcontroller along with ultrasonic sensor, accelerometer, GPS and GSM modules shorten the alarm time to a large amount and locate the site of accident accurately. Subsequently, the time for searching the location is reduced and the person can be treated as soon as probable which will save many lives. This system will have broad application forecast as it integrates the positioning systems and the network of medical based services. In the existing accident detection systems there is the problem of false alarms or situations where immediate help is not necessary. In such cases the driver must be able to manually switch off the alert system and stop the sending of message.

Key Words: Microcontroller, buzzer, accelerometer sensor, GSM & GPS module, LCD.

1. INTRODUCTION

The beginning of technology has also increased the traffic hazards and the road accidents. Due to the lack of best emergency facilities available in our country the lives of the people are under high risk. An automatic alarm device for vehicles is introduced in this paper which sends the essential information to the medical salvage team within a few seconds of an accident. This device can sense accidents and sends an alert message to rescue teams in significantly less time which will help in saving the lives of the people. The attentive message contains the geographical coordinates, time and angle in which the accident has occurred. In cases where there is no casualty the message can be terminated with the help of a switch in order to avoid wasting the valuable time of the rescue team. When an accident occurs it is detected with facilitate of a sensor which activates the device, the sensor gives its output to the microcontroller. The microcontroller sends the alert message automatically to the police station and the relatives of the person. The message is sent throughout the GSM module and the location of the accident is detected with the help of the GPS module. Consequently with this project execution we can identify the position of the vehicle where the accident has occurred so that we can give the first aid as early as possible.

2. STANDARD PROCEDURE

2.1 WORKING

1. In this project while a car met an accident, at that time the accident will be detected by the vibration sensor or accelerometer. An accelerometer can be used in a car alarm application so that risky driving can be detected.

2. It can be used as a crash or rollover detector of the vehicle through and after a crash. With signals from an accelerometer, a severe accident can be acknowledged. According to this assignment when a motor vehicle meets with an accident instantly Vibration sensor will sense the signal or if a car rolls over, a Micro electro mechanical system (MEMS) sensor will detects the specific signal and sends it to ARM controller.

3. Immediately microcontroller sends the signal to GPS module to give the exact value of the geographical coordinates which contains the value of longitude, latitude and altitude. After that the microcontroller sends the alert message through the GSM MODEM including the coordinates value of GPS to the medical rescue team and a police control room.

4. Then the medical help center will conform the location of the accident by analyzing the co-ordinates value of GPS on a map. Once the medical help center get the location of accident, it will inform the medical rescue team which in near to the location of the accident so that the injured party can get the treatment as fast as possible.

5. Also our system will send the message to the police control room so that their required investigation can be done in very less time and the medical rescue team is allowed to provide the treatment to the injured party.

2.2GPS

GPS is one of the trendy systems in communication. Global positioning system technology became a reality throughout the efforts of military of the American. It recognized a satellite-based navigation system consisting of a network of group of satellites orbiting the earth. There are 24 satellites in a system. GPS is also acknowledged as the NAVSTAR. It operates all across the world. It works in all weather conditions. It helps users to track locations since well as objects. By using GPS technology we can track each entity having GPS receiver. Consequently we can say that the GPS

technology can be used by any person having GPS on the earth.



Fig-1 GPS module

2.3 GSM

Global System for Mobile communication is a standard accepted worldwide for mobile communication. GSM/GPRS module is used for establishing communication link between a computer and a GSM-GPRS system. GSM is an architecture used for mobile communication in number of countries in the world. GPRS (Global Packet Radio Service) is an addition of GSM. It allows higher data transmission rate for the well-organized communication purpose. GSM/GPRS component consists of a GSM/GPRS modem assembled together. It is assembled among power supply circuit and communication interfaces like RS-232, USB, etc. for users computer. We are using Sim800 in our system.



Fig-2 GSM Module

2.4 Hardware Description

1. Accelerometer sensor- Acceleration and vibration is sensed by accelerometer. It defines a measure of how rapidly speed changes. Accelerometer sensor is used to measure dynamic acceleration or static (earth Gravity). It measures acceleration in all 3 axes. Those three axes are forward/backward, left/right and up/down.

2. LCD-The LCD screen is used to display the operating instructions and position of the output.

3. Buzzer- Buzzer is an electrical device, which is like to a bell that makes a buzzing noise and is used for signaling.

4. MAX232- The MAX232 is a dual transmitter/dual receiver that normally is used to convert the RX, TX, CTS and RTS signals. It is an integrated circuit which converts the signals from the RS232 serial port to the suitable signal which are used in the TTL well-suited digital logic circuits.

5. RESET-The reset button is used to reset the microcontroller at any point of work. It can be used to finish the sending of the message. If the reset button is pressed, the microcontroller restarts and the function will start from the beginning.

6. GPS- The GPS detects the latitude and longitudinal positions of the motor vehicle. It is used for equally tracking and navigation, GPS receiver can pinpoint the location using a process called trilateration.

7. GSM- The GSM sends the message through the location to the pre saved numbers. It is also used to organize and monitor the transformer load from wherever by sending a message.

8. LM35 temperature sensor- The LM35 series are accuracy integrated-circuit temperature sensors, whose output voltage is linearly comparative to the Celsius (Centigrade) temperature. The output of sensor converted to digital that simple linking with microcontroller.

9. Ultrasonic Sensor- As the name indicates, ultrasonic sensors compute distance by using ultrasonic waves. The sensor head emits an ultrasonic wave and receive the wave reflected back from the specific target. Ultrasonic Sensors compute the distance to the target by measuring the time between the production and reception

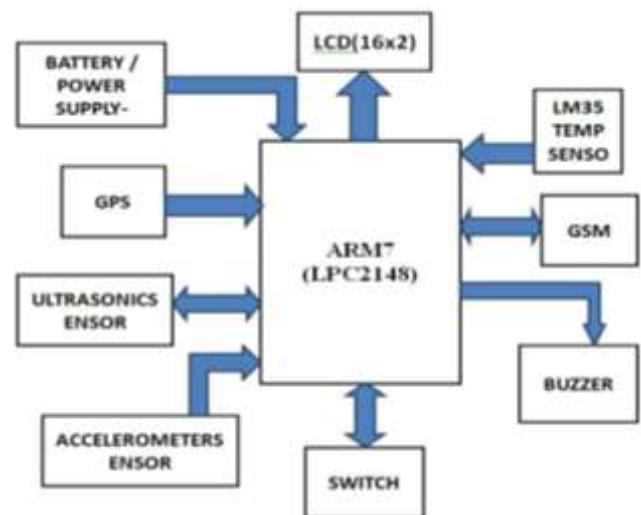

Fig-3 Block Diagram

3. Advantages

1. Automotive and transport vehicles.
2. The instant medication provided to the accident Victims in the remote area.
3. This system also can be interfaced with vehicle alerting system

4. Easy to operate
5. Sophisticated security
6. Simple and Reliable Design
7. Isolates both GSM and GPS signal.
8. Stolen Vehicle Recovery, both customer and commercial vehicles can be equipped with RF or GPS units to allow police to do tracking and recovery.
9. Intelligent high-tech safety system.

4. APPLICATIONS

1. Used in automotive and transport vehicles from lighter vehicles like cars, to heavier automotive like ships and aero planes.
2. Security and remote monitoring of vehicles in particular during military operations.
3. This system is also can be interfaced with Vehicle airbag system such that when the sensors detect the accident, the air bags get opened.
4. School transport vehicle accident detection.
5. This project can be used for cab or car of companies.

5. CONCLUSION

In this project, we comprise effectively designed vehicle accident detection and tracking system by using GSM and GPS. When accident occurs, it senses by PUSH ON SWITCHES. The coordinates of location of accident obtained by GPS, are sent via GSM network to user defined mobile number. It is the fact that implementation of system will increase cost of vehicle but it is better to have some percent safety rather than having no percent of safety.. The proposed method is verified to be highly beneficial for the automotive industry. The proposed system can also be used for traffic inference and accidents inspection in the country by health department with slight modification.

6. REFERENCES

- [1] "THE 8051 MICROCONTROLLER AND EMBEDDED SYSTEMS" by Muhammad Ali Mazidi and Janice GillispieMazidi, Pearson Education.
- [2] "AUTOMATIC VEHICLE ACCIDENT DETECTION AND MESSAGING SYSTEM USING GSM AND GPS MODEM" by C. Prabha, R. Sunitha, R. Anitha, IJAREEIE 7, July 2014.
- [3] "CAR ACCIDENT DETECTION SYSTEM USING GPS, GSM AND BLUETOOTH" by Vikram Singh Kushwaha, Deepa Yadav, IJERGS May-June 2015.

[4] "VEHICLE ACCIDENT DETECTION AND REPORTING SYSTEM USING GPS AND GSM." by Aboli Ravindra Wakure, Apurva Rajendra Patkar, IJERGS April 2014.

[5] GSM modem Wireless Communication by THEODORE RAPPAPORT

[6] Y. Zhao - "Mobile phone location determination and its impact on intelligent transportation systems".

[7] Design of vehicle positioning system based on arm IEEE-2011. Zhang Wen; Dept. of Phys. & Electron. Inf. Eng., Neijiang Teachers Coll., Neijiang, China; Jiang Meng may 2011.

[8] "Power Electronics" by M D Singh and K B Khanchandan.

[9] "Linear Integrated Circuits" by D Roy Choudary & Shail Jain. [10] Electrical Machines" by S K Bhattacharya.