

Comparative Analysis between PI and Fuzzy Controller for Speed Control of Induction Motor

Prof. B. Sampathkumar¹, Kangale Shubhangi Shital², Kamble Prajkta Rajendra³

¹Assistant Professor at Electrical Department of Fabtech technical Campus, Sangola, Maharashtra, India

^{2,3}Student at Electrical Department of Fabtech technical Campus, Sangola, Maharashtra, India

Abstract - This paper portrays the way of implementing fuzzy logic in improving the performance of induction motor drive. Here a rule-based fuzzy logic based controller is designed and simulated with the help of mat lab. A pi controller is also designed in Simulink. Then performances of both the controller are simulated and compared. For controlling speed here scalar control method is employed, where magnitude of the stator voltage and frequency is changed proportionately. For this v/f control, a reference speed is chosen and controller is designed as such, it can provide that desired (reference) speed in case of frequent load changes. The major merit of fuzzy controller over pi controller is use of linguistic variable and user defined rule base that makes it possible to incorporate human intelligence in the controller. Fuzzy logic based controller also has the capability to control both linear and nonlinear system.

Key Words: V/F Control method, Fuzzy logic Control, PI Control, Speed Variation, MATLAB Simulation, etc.

1. INTRODUCTION

In recent years the control of high-performance induction motor drives has received widespread research interests. It has been valued more not only because it is the most used motor in industries but also due to their varied modes of operation. Also it has good self-starting capability, simple, rugged structure, low cost and reliability etc. main property that makes it more useful for industries is its low sensibility to disturbance and maintenance free operation. Despite of many advantages of induction motor there are some disadvantages also. Like it is not true constant speed motor, slip varies from less than 1% to more than 5%. Also it is not capable of providing variable speed operation. But as it is so useful for industries we have to find some solution to solve these limitations and the solution is speed controller that can take necessary control action to provide the required speed. Not only speed, it can control various parameters of the induction machine such as flux, torque, voltage, stator current. out of the several methods of speed control of an induction such as changing no of pole, rotor resistance control, stator voltage control, slip power recovery scheme and constant v/f control, the closed loop constant v/f speed control method is most popular method used for controlling speed.

In this method, the v/f ratio is kept constant which in turn maintains the magnetizing flux constant that eliminates harmonic problem and also the maximum torque also does not change. So, it's a kind of complete utilization of the motor. And the controller used is conventional p-i controller, and fuzzy logic controller.

2. PI- Controller

Induction machines are most frequently used in industries due to their robustness, low cost and reliability and high efficiency. Squirrel cage rotor, is the most widely used source of mechanical power fed from ac power system due to its low sensitivity to disturbance. In spite of many advantages induction motor has two inherent limitations during starting, induction motor draws large current which produces voltage dips oscillatory torques and also able to generate harmonics in the power system. When accuracy in speed response is a concern, closed-loop speed control is implemented. With the constant v/f control. A PI- controller is employed to regulate the slip speed of the motor to keep the motor speed at its set value.

2.1 Closed loop v/f speed control method by using PI- Controller:

Speed control could have been done with open-loop also. Open-loop control is the simplest type of control without any feedback loop, and without much complexity. But there lies many advantages of closed loop control over open loop control, for which closed loop control is preferred over open loop control.

The controlled variable (speed) accurately follows the desired value (specified speed).

Effect of external disturbances on controlled variable (speed) is very less also; use of feedback in the control greatly improves the speed of its response compared to that of open-loop case.

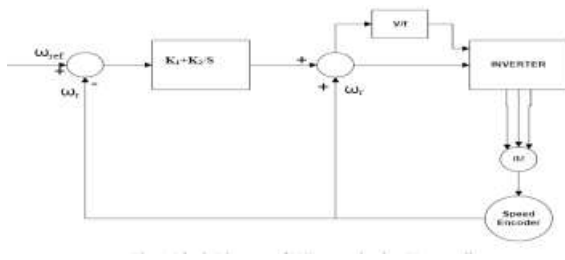

Fig 2.1.1 Block diagram of V/F Control using PI Controller

Closed loop speed controller with p-i controller adds some performance improvement to open-loop v/f control. The speed loop error generates a command through the p-i controller and limiter. That slips command again added to the feedback speed signal to generate frequency command. The frequency command again generates corresponding voltage command to have constant flux. With change in loading generally speed gets decreased to some value lower than the previous value. But as this drive is constant speed drive, if speed gets decreased with loading, the speed error loop start working spontaneously and give the command to increase the frequency to such a value so as to maintain that constant value of speed.

First a closed loop v/f control with p-i controller is simulated where p-i controller and vsi will be connected to the induction motor. then a feedback of rotor speed will be taken from the induction motor and compared with the reference speed and then the error will be fed to the controller and output of the p-i controller will fed to the vsi. In that way performance of induction motor with this controller is studied.

3.1 Fuzzy logic Controller:

Fuzzy logic is a superset of Boolean logic which has been extended to handle the concept of partial truth- truth values between "completely true" and "completely false". it is the logic basic modes of reasoning which are approximate rather than exact. Fuzzy logic replicates human knowledge in to control logic. The essential characteristics of fuzzy logic as founded by zader lotfi are as follows.

- Any logical system can be fuzzified.
- In fuzzy logic, knowledge is interpreted as a collection of elastic or, equivalently, fuzzy constraint on a collection of variables.
- No need of any exact mathematical model.

So the main purpose of designing fuzzy controller is to embody the human intelligence or human like thinking in the controller to control the process parameters. Fuzzy controller basically contains four essential segments

3.2 Configuration of fuzzy logic Controller

Principal components of fuzzy logic controller:

1. fuzzification block or fuzzifier
2. knowledge base
3. decision making block
4. defuzzification block or defuzzifier

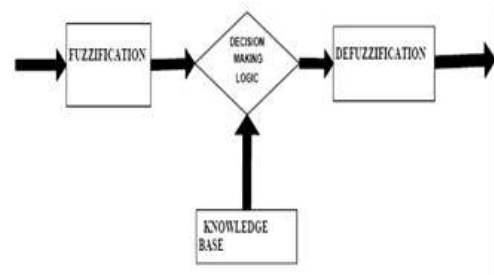

Fig 3.2.1 Block diagram of Fuzzy Controller

3.2.1 Fuzzifier:

As discussed previously fuzzy logic based on linguistic variable but since input given to the flc block is in numeric form so first thing to be done is to convert the numerical data/variable into linguistic variable and this task is performed by the fuzzifier. So fuzzifier converts the numerical variable given to the flc into linguistic variable. This fuzzification task includes choosing proper mf for the variables so that the crisp inputs can be converted into fuzzy sets.

3.2.2 Knowledge base:

Knowledge base is consist of rule base and data base. The main aim of data base is to provide necessary definitions needed to define the linguistic control rules and the aim of rule base is to characterize the control goals and policies by using a set of linguistic or if-then rules. In the if-then statement, if part is called antecedent and the then part is called consequence.

3.2.3 Decision making block:

It is the most important component of a fuzzy controller because it is the block decides the output depending upon the input. Based on fuzzy concepts, data and rule bases, it provide reasonable output.

3.2.4 Defuzzifier:

It performs the task just opposite to that of fuzzifier. So the task of defuzzifier is to convert the linguistic variable into

crisp one. There are different types of defuzzification techniques present for defuzzification.

1. Centroid of Area (COA)
2. Bisector of Area (BOA)
3. Mean of Maximum (MOM)
4. Smallest of Minimum (SOM)
5. Largest of Maximum (LOM)

For designing a fuzzy logic based controller, first thing we have to decide is what will be the inputs. As our main aim is to provide constant speed during load changes so the variable to be controlled will be speed. The fuzzy controller controlled drive is providing better results in improving the performance of the induction motor than pi controller. Whenever the machine is loaded, the speed of the machine fell to some extent but this fall in speed is very less in case of fuzzy controller controlled drive. So we can say that overshoot is more in case of pi controller and overall we can say that fuzzy controller is proving better result than pi controller.

4.1 MATLAB Simulation

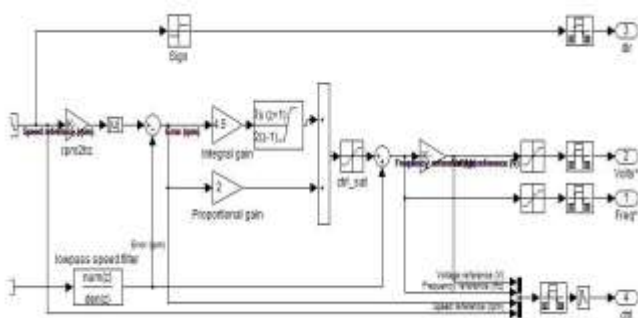

Fig 4.1.1 Simulation diagram of PI Speed controller

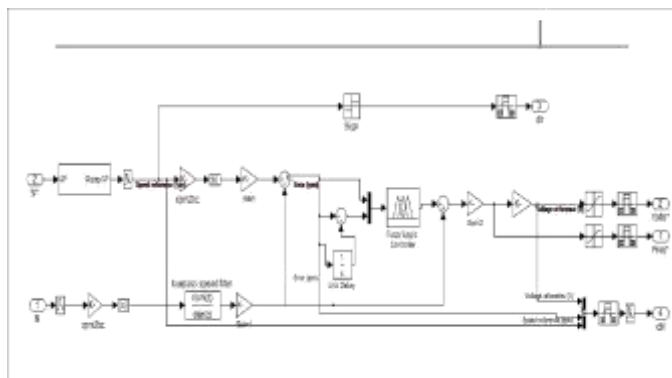

Fig 4.1.2 Simulation diagram of Fuzzy Logic Speed controller

5.1 Result

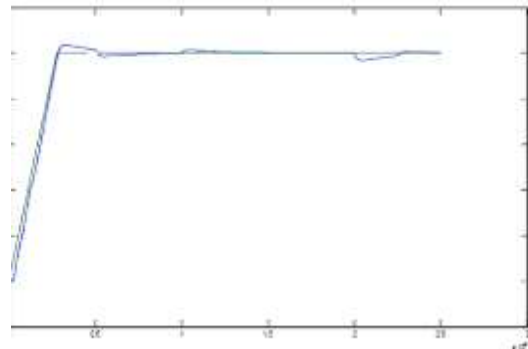

Chart 5.1.1 Speed vs. Time Plot with PI Controller

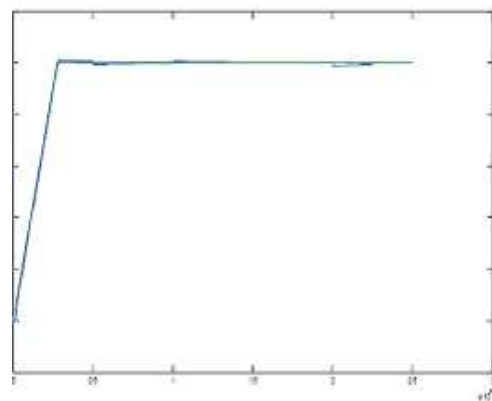

Chart 5.1.2 Speed vs. Time Plot with Fuzzy logic Controller

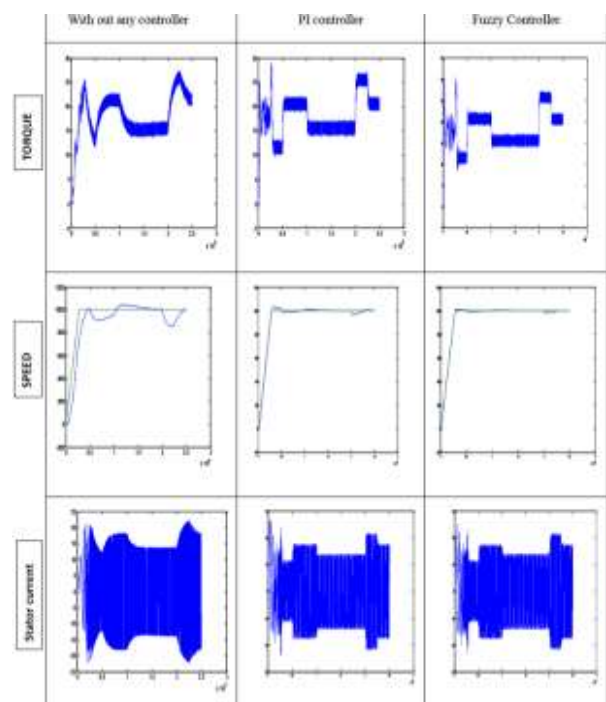

Chart 5.1.3. Comparison between different Controller

6. Conclusion

The main objective or the main concern of this project is to control the speed and provide better performance with frequent load changes. With this objective we focused to develop a fuzzy logic based controller with possible precision. For that we have chosen appropriate membership function and some if-then rules. Also we tried to tune the controller by slightly changing mfs and rules.

In this project a fuzzy logic based controller is designed with the help of mat lab, which can be utilized in speed control of induction motor. The controller takes numerical input of speed error (e) and change in speed error (δe), processes those inputs according to the rule framed and then provide a output called change in control. All the rules have been verified with the help of fis editor rule viewer. Results are also shown for different error and change in error. After simulating and comparing the results with conventional controller, it is concluded that fuzzy controller works efficiently for induction motor drive.

7. Future Scopes:

Both the speed controller block based on fuzzy logic and the block diagram to control the speed of induction motor using that speed controller. These blocks are simulated and results are analyzed. Also the controller is tuned when needed to provide desired results. This control mechanism based on fuzzy logic is not restricted to the induction motor only. It is applicable and can be used for other areas also. Now days a number of fuzzy logic-based precision environmental control systems are also available which are used for applications such as digital switching sites. Tuning of fuzzy controller has become easy due to different strategies like genetic algorithm.

8. References:

- [1] j.-s. r. jang, c.-t. sun, e. mizutani, "neuro fuzzy and soft computing," pearson education pte. ltd., isbn 81-297-0324-6, 1997, chap. 2, chap. 3, chap. 4.
- [2] gilberto c. d. sousa, bimal k. bose and john g. cleland, "fuzzy logic based on- line efficiency optimization control of an indirect vector-controlled induction motor Drive" *IEEE transaction on industrial electronics*, vol 4, no 2, April 1995.
- [3] g. el-saady, a.m. sharaf, a. makky, m.k. sherriny, and g. mohamed, "a high performance induction motor system using fuzzy logic controller," *iee trans.* 07803-1772-6/94, pp. 1058-1061, 1994.
- [4] r.ouiguini, k. djefal, a.oussedik and r. megartsi, "speed control of an induction motor using the fuzzy logic approach.", *isie'97 - guimariies, portugal*, *iee catalog number: 97th8280*, vol.3, pg. 1168 - 1172.

[5]martínez garcía, j.a. domínguez, "comparison between fuzzy logic and pi controls in a speed scalar control of an induction machine," *Circe - ge3 - department de ingeniería eléctrica c.p.s., Universidad de zaragoza*, conf. paper

[6] k.l.shi,t.f.chan,y. k. yong and s.l.ho: "modeling and simulation of three phase induction motor using simulink/matlab",*iee transactions on industry applications*,vol.37,no.5,september/october2001.

[7] abdullah i. al-odienat, ayman a. al-lawama, "the advantages of pid fuzzy controllers over the conventional types," *american journal of applied sciences* 5 (6):653-658, 2008, issn 1546-9239,pp.653-658.