

Automated Water Quality Monitoring System for Aquaponics

Abel Kurian Oommen¹, Adarsh Saji², Shilpa Joseph³, Prof Babu P Kuriakose⁴

^{1,2,3}Student, Dept. of Electronics and Communication Engineering, Mar Athanasius College of Engineering, Kothamangalam, Kerala, India

⁴Associate Professor, Dept. of Electronics and Communication Engineering, Mar Athanasius College of Engineering, Kothamangalam, Kerala, India

Abstract - Aquaponics is a technique for food production which combines both traditional methods of hydroponics and aquaculture to grow both crops and fish in a single integrated system. This system uses fish wastes to provide essential nutrients for the plant growth. In return plants serve as a bio-filter to remove harmful by-products of fish waste. The purpose of this project is to build an automated water quality monitoring system for Aquaponics using Internet of Things (IoT) application. This system helps the farmers to monitor pH, temperature, ammonia and nitrate level of water used in an aquaponic system. This helps the farmers to reduce manual effort and safeguard a balanced system where fish, plant and bacteria are in dynamic equilibrium. Due to the unavailability of low cost electronic sensors for ammonia, nitrate and nitrite level detection, an automated concentration measurement system is introduced in this project, which detects these ion concentrations in water using chemical reagent tests. The prime objective is to detect the concentration from the colour developed in the test solution, which is prepared by mixing sample and reagent. The whole procedure is automated and given wireless control with the help of Wi-Fi.

Key Words: Aquaponics, Automation

1. INTRODUCTION

Aquaponics is a technique for food production which combines both traditional methods of hydroponics and aquaculture in a single integrated production system. Aquaculture is the captive rearing and production of fish and other aquatic animal and plant species under controlled conditions. Hydroponics is a soil-less culture where plants are grown either on a substrate or in an aqueous medium with bare roots. This is a high profit farming method, and would require only little upkeep, once the initial setup is done. And this is also a 100% organic chemical free farming method. The important thing in such a system is the requirement of a proper water quality monitoring. Otherwise the whole system could fail. This requires a lot of human effort, as the farmers need to constantly test water quality manually and that too at various units in a farm. Electronic sensors for ammonia, nitrate and nitrite are very expensive and it requires frequent replacement. With the available devices, continuous water quality monitoring is not

possible. They need to be properly handled and we can't keep them on-site. This project proposes a system which will replace manual testing of ammonia, nitrite, nitrate and pH concentration by analysing the colour developed when the water react with some chemical reagents used commonly by farmers. The developed colour is compared and the corresponding concentration will be obtained. Dynamics of ammonia, nitrite, nitrate and pH concentration of water in fish tank, bio filter and grow beds are measured under different conditions. These measured readings are communicated to the base station and to the user wirelessly with the aid of Wi-Fi technology. Continuous water recirculation leads to higher power requirement. The proposed system is able to optimize the power usage for water circulation. Now lots of people are coming forward towards agriculture and hydroponics is a better method through which less capital investment and huge production can be made possible. Now our government is providing huge support including financial assistance, technical knowhow, subsidies and even high quality seedlings. The fisheries department is keen about the development of good projects by providing proper technical assistance and awareness to the farmers. So in such a scenario improvising the current technology of water quality management through an automated window could soon contribute to a better production. And the objective of this project is to lend a hand to the current agriculture revolution.

2. OBJECTIVE

Due to rapid urbanization, land resources for agriculture has been decreasing. Rapid growth of human population has also increased the demand for food. Traditional agriculture methods for growing plants require huge land space, time, and manpower. Consequently, there is an increasing concern for safe and sustainable food sources, which leads to the need for new agriculture methods. Aquaponics has emerged as an increasingly popular food production method. A basic aquaponics setup combines fish farming with hydroponic agricultural farming. Hydroponic agriculture refers to growing plants without soil, instead using nutrient enriched

water. By combining hydroponics with fish farming, food producers can increase their output, create a sustainable farming system, and maximize space usage. However, Aquaponics system design is complicated by the widely different needs of both plants and fish. A basic aquaponics setup must be supplied with good water. However, even the best source water will not ensure a proper balance between the hydroponic needs of the plants and the needs of aquaponic fish farming. Good aquaponics system plans will include frequent testing. When first building and implementing your aquaponic system, daily testing should be conducted. Dissolved oxygen, pH levels, conductivity or total dissolved solids, ammonium ion (NH_4^+), and nitrate ion (NO_3^-) must all be closely monitored. It's important to keep an eye on dissolved oxygen, pH levels, dissolved solids, and other factors. Although there are well known and widely used methods for measurement of these parameters with appropriate Sensors, design of electronic systems for environmental monitoring is not often straightforward. The engineering challenges are various such as sensor nodes are usually deployed in remote places, long-term deployments require sensor nodes to be robust and systems to be easily reconfigurable, sensor nodes have to be able to operate autonomously in the required environment, etc. Moreover, such applications require highly reliable and accurate sensors with the reduced level of maintenance, long lifetime, fast response times, high sensitivity and high selectivity. As a better method the water quality can be efficiently and economically managed by using chemical reagent testing which is done timely under an automated system. The main objective of the project is to build an automated system, which monitors the water quality of various sections in an Aquaponics system. Since, the electronic sensors for Ammonia, Nitrate and Nitrite are very expensive, find an affordable alternative for the farmers which are fully automated. And thus, help the farmers to increase the efficiency and productivity of his farm without much human intervention and thus safeguard the balance of different species involved.

3. LITERATURE SURVEY

The paper "Important Water Quality Parameters in Aquaponics", by Rossana Sallenave, discusses the importance of water quality in an aquaponics system. Maintaining a balance between water quality conditions that are optimal for fish, nitrifying bacteria, and plants is crucial to a healthy and productive aquaponics system. By monitoring key water quality parameters such as pH, temperature, dissolved oxygen, ammonia and nitrate on a

regular basis, adjustments can be made in a timely manner to avoid problems and losses in productivity.

The paper "Research on a liquid colour detecting device" by Zhen Zhou, Dixing Li, Yong Qin, Lifeng Liu, they propose a new liquid colour detecting device, using the latest TCS3200 colour sensor and STM32 microcontroller, combining with the improved optical system. Their results show the accuracy they obtained with the help of the new device and the drawback of earlier devices.

'Small-scale aquaponics food production Integrated fish and plant farming' by Christopher Somerville and Moti, is a technical paper which provide a prescriptive approach to aquaponics; this is a resource paper and includes description and discussion of the major concepts needed for aquaponics. It discusses the main theoretical concepts of aquaponics, including the nitrogen cycle and the nitrification process, the role of bacteria, and the concept of balancing an aquaponics unit. The publication discusses in detail the three groups of living organisms (bacteria, plants and fish) that make up the aquaponics ecosystem. guidelines and considerations for establishing aquaponic units; a cost-benefit analysis of a small-scale, media bed aquaponic unit; a comprehensive guide to building small-scale versions of each of the three aquaponic methods. It also presents management strategies and troubleshooting practices, as well as related topics, specifically highlighting local and sustainable sources of aquaponics inputs.

The paper "Petroleum products color detecting system using RGB color sensor" by Song Jinbo, Duan Zhiwei shows the methods which they adopted for the petroleum products liquid colour detection along with their final test results. The petroleum products are properly separated and the different components are now tested by transmission type testing measures.

4. AQUAPONICS

Aquaponics is the integration of recirculating aquaculture and hydroponics in one production system. In an Aquaponics unit, water from the fish tank cycles through filters, plant grow beds and then back to the fish (Fig -1). In the filters, the fish wastes are removed from the water, first using a mechanical filter that removes the solid waste and then through a bio filter that processes the dissolved wastes. The bio filter provides a location for bacteria to convert ammonia, which is toxic for fish, into nitrate, a more accessible nutrient for plants. This process is called

nitrification. As the water (containing nitrate and other nutrients) travels through plant grow beds, the plants uptake these nutrients, and finally the water returns to the fish tank purified. This process allows the fish, plants, and bacteria to thrive symbiotically and to work together to create a healthy growing environment for each other, provided that the system is properly balanced. In Aquaponics, the aquaculture effluent is diverted through plant beds and not released to the environment, while at the same time the nutrients for the plants are supplied from a sustainable, cost-effective and non-chemical source. This integration removes some of the unsustainable factors of running aquaculture and hydroponic systems independently. Beyond the benefits derived by this integration, aquaponics has shown that its plant and fish productions are comparable with hydroponics and recirculating aquaculture systems. Aquaponics can be more productive and economically feasible in certain situations, especially where land and water are limited. However, aquaponics is complicated and requires substantial start-up costs. The increased production must compensate for the higher investment costs needed to integrate the two systems.

preventing the water from becoming toxic with harmful forms of nitrogen (ammonia and nitrite), and allows the fish, plants, and bacteria to thrive symbiotically. Thus, all the organisms work together to create a healthy growing environment for one another, provided that the system is properly balanced.

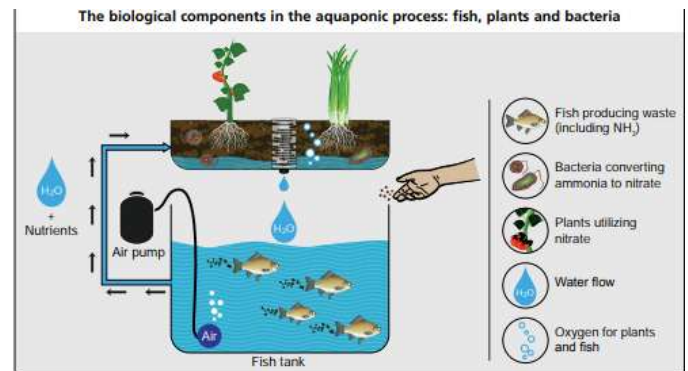

Fig -2: Biological component in the aquaponics process

Nitrifying bacteria, which live in diverse environments such as soil, sand, water and air, are an essential component of the nitrification process that converts plant and animal waste into accessible nutrients for plants. This natural process of nitrification by bacteria that happens in soil also takes place in water in the same way. For aquaponics, the animal wastes are the fish excreta released in the culture tanks. The same nitrifying bacteria that live on land will also naturally establish in the water or on every wet surface, converting ammonia from fish waste into the easily assimilated nitrate for plants to use. Plants are able to use both ammonia and nitrates to perform their growth processes, but nitrates are more easily assimilated by their roots.

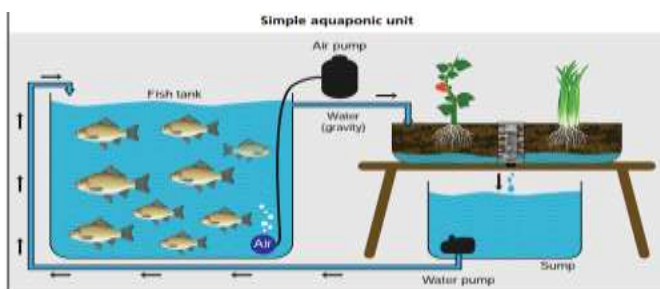

Fig -1: Aquaponics system

4.1. IMPORTANT BIOLOGICAL COMPONENTS OF AQUAPONICS

Aquaponics is a form of integrated agriculture that combines two major techniques, aquaculture and hydroponics. In one continuously re-circulating unit, culture water exits the fish tank containing the metabolic wastes of fish. The water first passes through a mechanical filter that captures solid wastes, and then passes through a bio filter that oxidizes ammonia to nitrate. The water then travels through plant grow beds where plants uptake the nutrients, and finally the water returns, purified, to the fish tank (Fig -2).

The bio filter provides a habitat for bacteria to convert fish waste into accessible nutrients for plants. These nutrients, which are dissolved in the water, are then absorbed by the plants. This process of nutrient removal cleans the water,

Organism type	Temp (°C)	pH	Ammonia (mg/litre)	Nitrite (mg/litre)	Nitrate (mg/litre)
Warm water fish	22-32	6-8.5	<3	<1	<400
Cold water fish	10-18	6-8.5	<1	<0.1	<400
Plants	16-30	5.5-7.5	<30	<1	-
Bacteria	14-34	6-8.5	<3	<1	-

Fig -3: General water quality tolerances for fish, hydroponic plants and bacteria

Nitrification in aquaponics systems provides nutrients for the plants and eliminates ammonia and nitrite which are toxic. General water quality tolerances for fish (warm or

cold-water), hydroponic plants and nitrifying bacteria is shown in the Fig -3. Each parameter has an impact on all three organisms in the unit (fish, plants and bacteria). Based on these parameters the tolerance level of fishes and the max level of ammonium content in water could be determined.

5. SCHEME OF PROJECT

The project design consists of a chamber enclosed in black box into which the test sample and reagent is mixed to form a homogenous solution. The accurate and precise inflow of liquid is made through the control of the time period of operation. The chemical reagent is injected by using a 12V DC dosing peristaltic pump. Now the water sample is added into the testing chamber by using an aquarium filter pump. Now this process is done repeatedly for one more time now proper mixing of the solution is done and the solution is developing a colour based on the amount of ammonia present. The colour is detected by using a colour sensor which is affixed inside the black box.

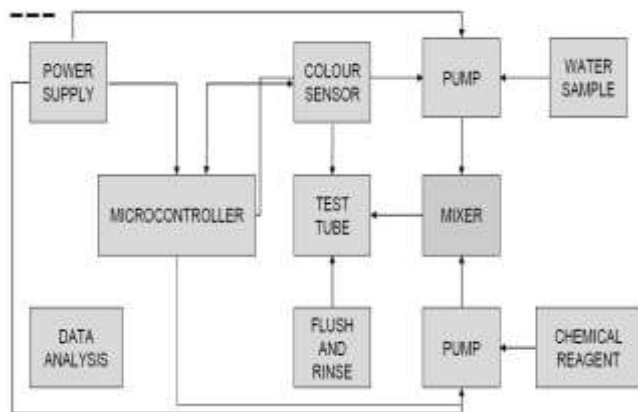

Fig -4: Components and layout

Continuous five values are observed and the average is taken. The value is now compared with a standard colour chart based on which, the parts per million (ppm) of ammonia is determined. After this the entire test sample is flushed out and then rinsed by using the water sample. This process is done on a periodic basis to ensure the water quality timely. The working of the system is fully automated and controlled via android application. The control is made through a nodeMCU unit ESP8266, to maintain an IOT based system.

6. HARDWARE DESIGN

Centralised concentration measurement system consists of a closed chamber. Initially the chamber is used for making the

test solution ready for colour detection. The chamber is a black enclosed region for measuring the colour of test solution. The chamber has both inlet and outlet valves. Initially the chamber is rinsed with the sample water, the inlet is enclosed by a cork, and where the different tubes carrying water and reagent is attached to it. The chamber actually made by a two side opened test tube. This chamber is used for the colour sample preparation and the colour testing. The outlet should be a precisely operated valve system which is a normal water pumping valve operated by a servo motor

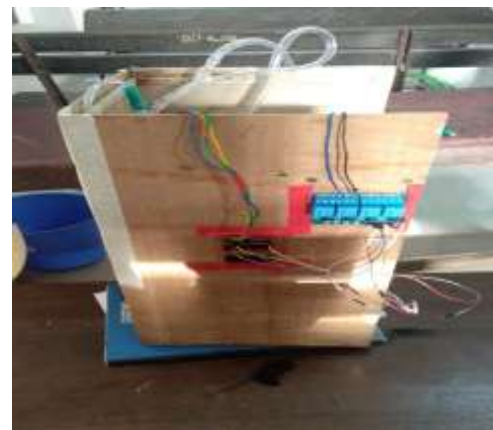

Fig -5: External casing



Fig -6: Reagent addition

The motor is rotated to open and close the valve. The amount of test solution (reagent) to be mixed with pond water is of very small quantity. This precise inflow is controlled with the help of 12v small dosing pump with a 2mm of peristaltic head. Once both the liquid entered in the chamber, it needs to be properly mixed. So the order in which the sample and the reagent taken into the test tube is adjusted, initially a small amount of water sample is added into the test tube, now a precise amount of reagent is added by using the peristaltic pump later another amount of

sample is added to ensure proper dilution and formation of a homogenous test solution.

The chamber is fully enclosed and the whole interior is black painted and have a test tube holder inside. Once the test solution is ready white LED which is placed at one side of test tube is triggered. A 16-bit resolution colour sensor VEML6040 is placed at the other side of the test tube. The Beer-Lambert law explains the linear relationship between concentration and absorbance of an absorbing species. We have initially measured the colour using reflection method but the measured readings were not satisfactory for our requirement later with the adoption of transmission method we obtained desired satisfactory readings which support our results.

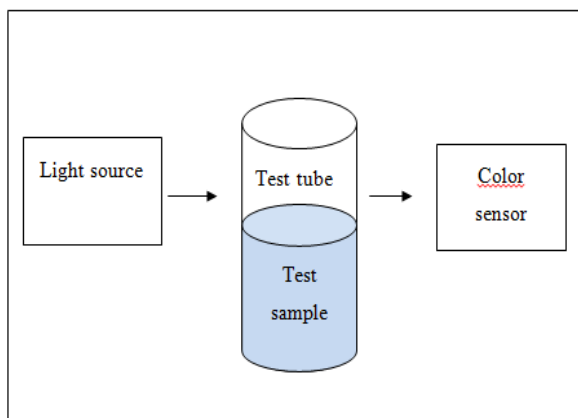

Fig -7: Colour testing setup

This colour sensor senses red, green, blue, and white light intensities with the help of corresponding filters. With the help of I2C protocol, controller is able to read the RGBW values, which is further matched with a look up table for the calculation of appropriate colour and hence the corresponding concentration. Once the sensor measured the RGB value, the outlet valve of chamber is made open. Now the system moves in to a cleaning phase where, the above said process will repeat with another test sample and thus will clean the chamber.

6.1. COMPONENTS

6.1.1 ESP8266

The ESP8266 is a low-cost Wi-Fi microchip with full TCP/IP and microcontroller capability. This module is taken to give a Wi-Fi controlled automation to the setup, it consists of 16 General Purpose Input Output (GPIO) pins. Its memory is of required size that is 32 KiB instruction RAM. Through this nodeMCU device it is possible to give automation and IOT access. ESP8266EX now has interfaces

for I2C master devices, and allows control and reading and writing over other I2C slave devices (e.g. most digital sensors). All GPIO pins can be configured with open-drain mode, thus easily enabling GPIO interface for I2C data or clock functionalities. Besides that, the chip has pull-up resistance inside which can help save the pull-up resistance outside. As an I2C master, ESP8266EX has its waveforms of the SDA and SCL lines simulated from SPI0, where SDA access is behind the positive edge of SCL. SCL high and low levels will maintain 5us and thus I2C clock pulse will be around 100KHz. The I2S module of the ESP8266 contains a Tx (transport) unit and a Rx (receive) unit. Both the Tx and the Rx unit have a three-wire interface that includes: Clock line; Data line; Channel selection line (the line for selecting the left or the right channel).



Fig -8: ESP8266 module

6.1.2 PERISTALTIC DOSING PUMP

A peristaltic pump is a type of positive displacement pump used for pumping a variety of fluids, they are also commonly known as roller pumps. The fluid is contained within a flexible tube fitted inside a circular pump casing (though linear peristaltic pumps have been made). A rotor with a number of "rollers", "shoes", "wipers", or "lobes" attached to the external circumference of the rotor compresses the flexible tube. As the rotor turns, the part of the tube under compression is pinched closed (or "occludes") thus forcing the fluid to be pumped to move through the tube. Additionally, as the tube opens to its natural state after the passing of the cam ("restitution" or "resilience") fluid flow is induced to the pump. This process is called peristalsis and is used in many biological systems such as the gastrointestinal tract. Typically, there will be two or more rollers, or wipers, occluding the tube, trapping between them a body of fluid. The body of fluid is then transported, at ambient pressure, toward the pump outlet. Peristaltic pumps may run continuously, or they may be indexed through partial revolutions to deliver smaller amounts of fluid. The flow of peristaltic pump connection depends on the power level of positive and negative terminals which can be set to an arbitrary chosen level. The motor speed is of 5000rpm.



Fig -9: Peristaltic pump

Its power supply is 12V, DC and it is used for precise and efficient addition of reagent into the chamber setup.

6.1.3 VEML 6040 COLOUR SENSOR

VEML6040 colour sensor senses red, green, blue, and white light and incorporates photodiodes, amplifiers, and analog / digital circuits into a single chip using CMOS process. With the colour sensor applied, the brightness, and colour temperature of backlight can be adjusted base on ambient light source that makes panel looks more comfortable for end user's eyes. VEML6040 achieves the closest ambient light spectral sensitivity to real human eye responses. VEML6040 provides excellent temperature compensation capability for keeping the output stable under changing temperature. VEML6040's function are easily operated via the simple command format of I2C (SMBus compatible) interface protocol. VEML6040's operating voltage ranges from 2.5 V to 3.6 V. VEML6040 is packaged in a lead (Pb)-free 4 pin OPLGA package which offers the best market-proven reliability. The sensor is enclosed within a black box in order to perform the transmission type colour sensing. The source is provided by LED.



Fig -10: VEML 6040 colour sensor

6.1.4 BLYNK

Blynk is an open source "internet of things" platform to store and retrieve data using Hyper Text Transfer Protocol (HTTP) over internet. It is a hardware-agnostic IoT platform with customizable mobile apps, private cloud, rules engine, and device management analytics dashboard it is a popular IoT platform to connect devices to the cloud, design apps to control them. Sensor data can be sent to Blynk from

microcontroller. With the help of Blynk the data analysis is made easier. All the fields in the corresponding channel are visible to the app user separately according to his needs. Moreover, this app provides the user with a nice data analysis environment as he can view the data according to his need. App will provide the data along with the exact value of ammonia in terms of ppm.

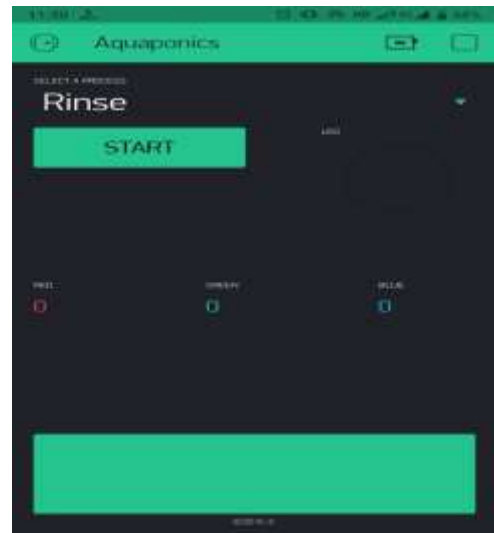

Fig -11: Colour chart Display

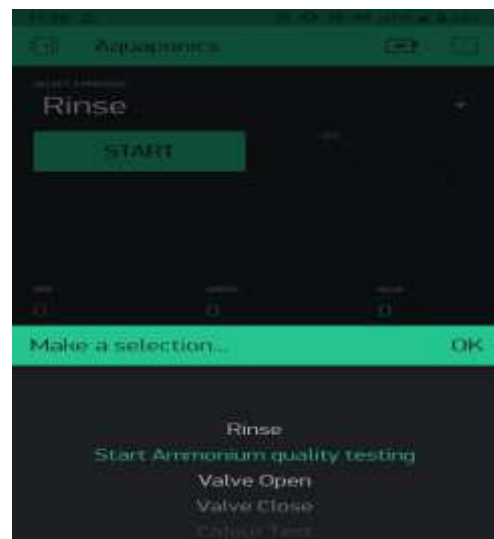

Fig -12: Process selection

7. SOFTWARE DESIGN

ESP826612E firmware is developed using Arduino IDE. Figure depicts the software flow diagram of automated concentration measurement system. The firmware consists of two main states. First it sets to colour detection state, and controls the open and close of inlet valves of chamber, one for sample and the other for reagent. After solution forms a

homogenous solution it is set idle for some time for the colour to be developed in the solution. Once the solution is ready for colour detection, the colour sensor is turned ON followed by colour detection where it takes consecutive five values and the average is displayed. Once colour detection is over, firmware turns on the outlet valve of chamber to remove the test solution. Later, its state is changed to cleaning. the chamber is cleaned with water and made ready for future testing. The open and close of each valve is controlled with the help of GPIO pins ON and OFF, using timers for specific time duration.

Colour Sensor is interfaced to MCU using I2C protocol, Red (R), Green (G), Blue (B) and White (W) intensities are read from VEML6040's internal registers. This value is further used for colour detection and thus concentration detection of solution. Based on the concentration it is possible to come to a conclusion about the water replacement. And this process is done periodically and thus helps in a continuous check over the water quality. The flow diagram will now explain the algorithm on which the entire process is working. Each process can be controlled by the android application where the farmer can be anywhere. The basic fact is that the password for the controlling android should be same as that given in the source code. The RGB rated colours observed can be now compared with a standard chart prepared based on the maximum permitted level of ammonia in the water and the amount of ammonia in water in terms of ppm is now displayed. The algorithm for this is done by comparing the values obtained with a standard range prepared with ammonium hydroxide solution in the same colour sensing apparatus. The process can be immediately terminated by the control through the android and also can be done multiple times a day. The timer for the operation of reagent and aquarium filter pump will determine the amount of content added. The software flow diagram is represented in the figure 14 which gives the brief view of the entire process done.

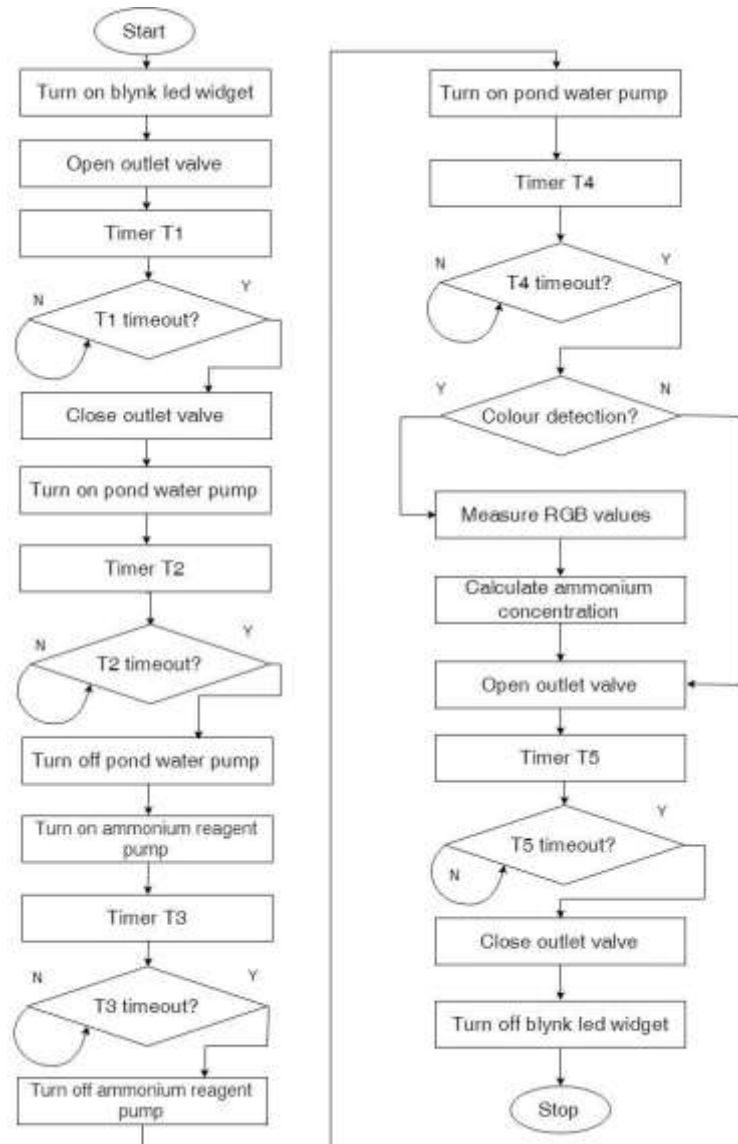

Fig -13: Software flow diagram

8. WORK LAYOUT

- 1) **Field visit and initial analysis:** for the proposed idea we visit an aquaponics farm nearby, 'Live catch aquaponics' where we come to know about the basic working of the system and the common problems faced by the farmers in ensuring the quality of the water. We took the water samples from different aquaponics ponds of varied capacity. Manual testing of the water sample is done, by using the reagent and the quality of water in terms of ammonia concentration is analysed. Later we brainstormed methodologies to overcome the problems faced in the present system.



Fig -14: Farm visit and sample collection

- 2) **Component identification:** The project layout is made and the different components are identified. Initially the valves were chosen to be solenoid valve but later it is quite difficult to meet the pressure requirements so this was replaced by peristaltic pumps, the chamber setup were made by using a glass tube and two ends are controlled by valve system. The opening and closure valve is fabricated by using a normal water valve controlled by a servo motor. The servo motor turning angle is adjusted and based on which the valve is opened and closed.



Fig -15: Bio filter

- 3) **Development and fabrication:** The hardware development is made and the circuits are connected. The software and android application is developed. The main problem we faced through all these time was about the precise detection of colour and so the sensor unit is enclosed within a black box. And the light source now placed within the Black box will be the only light available in the setup. We were trying to increase the precision bit rate of the colour sensor to obtain a better result. Since the setup is prone to water leakage, after affixing tubes and chamber it is completely sealed.

The entire setup is enclosed within a casing. All the components are affixed onto the casing.



Fig -16: Fish pond



Fig -17: Grow bed

- 4) **Testing and improvising:** The colour testing is done by using the setup. And testing is done. The colour chart is tabulated to the colour code value by using known concentration of ammonia. We took different known concentration of ammonium hydroxides and mixed the samples with reagents and formed colours based on the concentration. This solution are tested inside the colour sensing chamber and recorded the rated colour values based on the range of colours obtained a standard permitted level is decided and this is used for comparing with the future test results. The colour formed is now detected by the colour sensor and the values are taken. This value will be acting as the standard chart to compare with the test samples.

This is now tested in the real field conditions and makes appropriate changes according.

entire system is at first rinsed and flushed by same water samples.

9. PROBLEMS FACED AND MODIFICATIONS

The main issues we faced throughout the project was an effective valve mechanism a voltage controlled solenoid valve is the component at the initial design phase but due to pressure requirement for operation of the valve. We were supposed to fabricate a valve which can be controlled and requires no pressure. Normal valve is turned by using a servomotor, an angle servomotor if the open and close is set by using angles it will rotate that particular angle and perform the required operation.



Fig- 18: Servo motor controlled outlet valve

The next main issue that we faced was about the surface tension inside the valve where we replaced the normal tubes with high quality tubes used for medical purposes. We also need an efficient method for proper mixing and formation of a homogenous solution, we thought of doing this with agitator or bubbling air later we adopted a method to mix the sample and reagent one after other for two three times so that proper mixing will take place here. The grit or sand entered into the tubes can cause the total malfunction of the system so we ensured that the filter pump has got with a mesh inside which will prevent the entry of some foreign substances. And while placing the filter pump inside the pond it is preferable to cover the opening with narrow mesh. And the case used in hardware set up is made in such a way if any block happened, it will be now easy for the farmers to disassemble the setup and clean the system. Sticking of chemical reagents and precipitates formed after the testing can also affect the quality of colour testing, this is sorted by the cleansing mechanism used in the algorithm where the

10. RESULTS AND DISCUSSIONS

We tested the water samples of different concentration and made a standard chart as per the test observations. The same testing environment is provided for creating the standard chart also. Now the android application will display the amount of ammonia based on the ppm value present in the solution by comparing with this standard chart and will display whether it is of low, medium or high concentration. The water quality is good for low concentration (preferably 0 ppm) and for medium(3ppm) the water should be removed within two or three days. And for high concentration (more than 3ppm) the water needs immediate attention as the health of fish is in vulnerable condition.

CONCENTRATION	RGB VALUES
LOW AMMONIUM CONCENTRATION (5 p.p.m of Ammonium)	R- 1925, G- 1003, B- 1371
MEDIUM AMMONIUM CONCENTRATION (3 p.p.m of Ammonium)	R- 3432, G- 1766, B- 2465
HIGH AMMONIUM CONCENTRATION (1 p.p.m of Ammonium)	R- 5213, G- 2641, B- 3415

Fig -19: The standardised colour chart for different ammonia concentration

The range of values for the RGB rating is used to determine the concentration as there will be always a slight variation of values. But it is observed that the test values always lie within a limited variation, so we set that range after testing the solution in the environment for a couple of times.so no other normalisation process is required to rate the colour chart.

11. CONCLUSION

Aquaponics is the integration of recirculating aquaculture system (RAS) and hydroponics in one production system. In an aquaponic unit, water from the fish tank cycles through filters, plant grow beds and then back to the fish. In the filters the water is cleaned from the fish wastes by a mechanical filter that removes the solid part, and a bio filter that processes the dissolved wastes. The bio filter provides a location for bacteria to convert ammonia, which is toxic for fish, into nitrate, a more accessible nutrient for plants. This process is called nitrification. As the water (containing nitrate and other nutrients) travels through plant grow beds the plants uptake these nutrients, and finally the water

returns to the fish tank purified. This process allows the fish, plants, and bacteria to thrive symbiotically and to work together to create a healthy growing environment for each other, provided that the system is properly balanced. Although the production of fish and vegetables is the most visible output of aquaponic units, it is essential to understand that aquaponics is the management of a complete ecosystem that includes three major groups of organisms: fish, plants and bacteria. In aquaponics, the aquaculture effluent is diverted through plant beds and not released to the environment, while at the same time the nutrients for the plants are supplied from a sustainable, cost-effective and non-chemical source. This integration removes some of the unsustainable factors of running aquaculture and hydroponic systems independently. With the help of automated water quality management system for Aquaponics, without human intervention, farmers are able to monitor the water quality, which helps to improve the efficiency and productivity of the unit. More over with the help of Blynk, a door is opened for the data analysis which helps to optimize the circulation of water and thus optimize the power requirement for the continuous water circulation. With this project an automated concentration measurement system with the help of colour detection is introduced which reduce the human intervention and thus will make the life of farmers easier.

12. FUTURE ADVANCEMENTS

In future, this prototype can be made into a product, which can include the detection of ammonia, nitrite, nitrate and pH in a single system. Also an efficient water management system can be inculcated into this system. An external battery backup can be provided to make this product portable. Also there is the possibility of powering the system through solar energy thereby making it possible for a sustainable mode of operation.

13. REFERENCES

[1] Rossana Sallenave, Important Water Quality Parameters in Aquaponics Systems, IEEE 4th Circular 680, NM State University, College of agricultural, consumer and environmental sciences, October 2016

[2] Zhen Zhou¹, Dixing Li¹, Yong Qin¹ and Lifeng Liu¹, Research on a liquid colour detecting device, Advanced Materials Research, Volume 981, July 2014

[3] Somerville, C., Cohen, M., Pantanella, E., Stankus, A. & Lovatelli, A. 2014. Small-scale aquaponics food production. Integrated fish and plant farming. FAO Fisheries and Aquaculture Technical Paper No. 589. Rome, FAO. 262 pp.

BIOGRAPHIES



Prof. Babu P Kuriakose

Project Guide, Dept. of ECE, Mar Athanasius College of Engineering, Kothamangalam, India



Abel Kurian Oommen

Student, ECE, Mar Athanasius College of Engineering, Kothamangalam, India



Adarsh Saji

Student, ECE, Mar Athanasius College of Engineering, Kothamangalam, India



Shilpa Joseph

Student, ECE, Mar Athanasius College of Engineering, Kothamangalam, India