

Enhancement of Power Flow Capability in Power System using UPFC- A Review

Shradha N. Waghade¹, Chandrakala Gowder²

¹PG Scholar, Dept. of Electrical Engineering, Shri Sai Collage of Engineering and Technology, Bhadrawati, Maharashtra, India

²Assistant Professor, Dept. of Electrical Engineering, Shri Sai Collage of Engineering and Technology, Bhadrawati, Maharashtra, India

Abstract – Flexible Alternating Current Transmission Systems (FACTS) technology opens up new opportunities for controlling power and enhancing the usable capacity of present as well as new and upgraded lines. The focus of this paper is a FACTS device known as the Unified Power Flow Controller (UPFC). With its unique capability to control simultaneously real and reactive power flows on a transmission line as well as to regulate voltage at the bus where it is connected, this device creates a tremendous quality impact on power system stability. These features turn out to be even more significant because UPFC can allow loading of the transmission lines close to their thermal limits, forcing the power to flow through the desired paths. This provides the power system operators much needed flexibility in order to satisfy the demands. The IEEE 5 bus network is a benchmark system taken in this paper in order to check the response of UPFC on the power flow enhancement. UPFC is modeled in different ways to analyze power flow and voltage improvement at each bus. In this paper UPFC is modeled as a Voltage Source Model (VSM) and that will generate reference bus voltage and phase angle at different load conditions on the receiving end of UPFC. The variation between the voltage generated by VSM and actual voltage profile in the bus is injected in the line through an injection transformer.

Key Words: FACTS, real and reactive power flow, IEEE 5 bus system, IGBT, UPFC.

1. INTRODUCTION

The continuing rapid development of high-power semiconductor technology now makes it possible to control electrical power systems by means of power electronic devices. These devices constitute an emerging technology called FACTS (flexible alternating current transmission systems). Its first concept was introduced by N.G Hingorani, in 1988 (FACTS) is very popular and essential device in power systems [1]. FACTS technology has a number of benefits, such as greater power flow control, increased secure loading of existing transmission circuits, damping of power system oscillations, less environmental impact and, potentially, less cost than most alternative techniques of transmission system reinforcement.

In order to have a better use of the transmission capabilities of the transmission lines, different types of FACTS devices have been studied: Static VAR Compensator (SVC), Thyristor controlled series capacitor (TCSC), Static synchronous compensator (STATCOM), Static series compensator (SSSC), Unified Power Flow Controllers (UPFCs), thyristor switched capacitor (TSC) thyristor controlled reactor (TCR) [2-10]. Several FACTS-devices have been introduced for various applications in power system.

The UPFC is the most versatile of the FACTS devices. It cannot only perform the functions of the static synchronous compensator (STATCOM), thyristor switched capacitor (TSC) thyristor controlled reactor (TCR), and the phase angle regulator but also provides additional flexibility by combining some of the functions of the above controllers. The main function of the UPFC is to control the flow of real and reactive power by injection of a voltage in series with the transmission line. Both the magnitude and the phase angle of the voltage can be varied independently. Real and reactive power flow control can allow for power flow in prescribed routes, loading of transmission lines closer to their thermal limits and can be utilized for improving transient and small signal stability of the power system.

This device combination of two other FACTS devices: the Static Synchronous Compensator (STATCOM) and the Static Synchronous Series Compensator (SSSC). Practically, these two devices are two Voltage Source Inverters (VSI's) connected respectively in shunt with the transmission line through a shunt transformer and in series with the transmission line through a series transformer. These are connected to each other by a common DC link, which is a typical storage capacitor [5-10].

2. LITERATURE REVIEW

In (2013) Hakim Elahi Tooraji and Nekoubin Abdolamir designed and simulated a Unified Power Flow Controller in multi-machine power system. The on-line designed process is based on PWM method which all the power quality parameters representing as voltage sag and swell can be improved. In the proposed control method, the

harmonic distortion of the system is decreased and the voltage oscillations of the DC capacitor will be improved. Simulations that are done by the PSCAD/EMTDC software show the effectiveness and precision of this designing [11].

In (2013) Kumar Gaurav and Nitin Saxena investigate the enhancement in voltage stability margin as well as the improvement in the power transfer capability in a power system with the incorporation of UPFC. A simple transmission line system is modeled in Matlab/Simulink environment. The load flow results are first obtained for an uncompensated system, and the voltage and power profiles are studied. The results so obtained are compared with the result obtained after compensating the system using UPFC to show the voltage stability margin enhancement [12].

In (2013) Vaibhav S Kale et, al. proposed the real, reactive power and voltage control through a transmission line by placing UPFC at the sending end using computer simulation. The control scheme has the fast dynamic response and hence is adequate for improving transient behavior of power system after transient conditions [13].

In (2015) Koganti et, al. studied Power quality and stability improvement of HVDC transmission System using UPFC for Different uncertainty conditions, they concluded that UPFC improves the system performance. It can control the power flow in the transmission line, effectively. With the addition of UPFC, the magnitude of fault current reduces and oscillations of excitation voltage also reduce. The total harmonic distortion (THD) is also reduced well below the IEC standards. It is more economical for the HVDC transmission system to transfer more power [14].

In (2015) Shantha Soruban et, al. proposed an ANN based control scheme for a UPFC to be used as an active power filter. The objective is to guarantee power to the load at the required power quality. The ANN control unit monitors the voltage at the point of common coupling. UPFC enables improved power quality by maintaining power factor nearer to unity rapid response time, the ability to provide reactive power at low voltage and to provide voltage compensation can be obtained. For unbalanced voltage compensation, two unbalanced controllers using the phase voltage amplitude and negative sequence component are proposed [15].

3. UNIFIED POWER FLOW CONTROLLER

UPFC is the most flexible multi-functional FACTS device which is a new generation of FACTS devices. The UPFC is one of the most versatile devices. In UPFC, the transmitted power can be controlled by changing three parameters of power transmission line namely transmission magnitude voltage, impedance and phase angle.

3.1 Basic principle of UPFC

The UPFC consists of two voltage source converters; series and shunt converter, which are connected to each other with a common dc link. Shunt converter (converter 1) or Static Synchronous Compensator (STATCOM) is used to provide reactive power to the ac system, besides that, it will provide the dc power required for both inverters, while series converter (converter 2) or Static Synchronous Series Compensator (SSSC) is used to add controlled voltage magnitude line as shown in fig. 1. Each of the branches consists of a transformer and power electronic converter. These two voltage source converters shared a common dc capacitor. The real power can freely flow in either direction between the ac terminals of the two converters. In this respect, converter 2 provides the main function by injecting an AC voltage V_{se} , at system frequency with variable magnitude $|V_{se}|$, ($|V_{se}| \leq 0 \leq |V_{se}| \max$) and phase angle ($0 \leq \gamma \leq 2\pi$) in series with the line. On the other hand, converter1 is used primarily to provide the real power demanded by converter2 at the common dc link [2].

The energy storing capacity of this dc capacitor is generally small. The reactive power in the shunt or series converter can be chosen independently, giving greater flexibility to the power flow control.

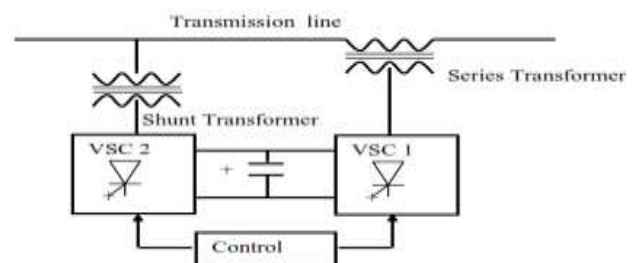

Fig -1: schematic diagram of the UPFC

Fig.2 shows Single line diagram of UPFC and Phasor of voltage and current to V [7]. This gives a new line voltage V_2 with different magnitude and phase shift.

As the angle φ varies, the phase shift δ between V_2 and V_3 also varies. Voltage and current with the presence of the two converters, UPFC not only can supply reactive power but also active power. The equation for the active and reactive power is given as follows,

$$P_{12} = \frac{V_1 V_2 \sin \delta}{X_{12}}$$

$$Q_{12} = \frac{V_1 V_2 (\cos \delta + 1)}{X_{12}}$$

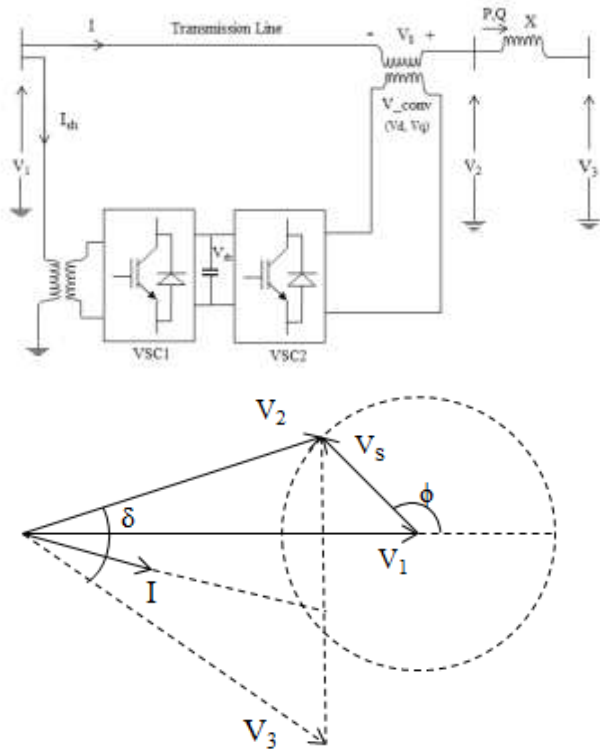

Fig – 2: Single line diagram of UPFC and Phasor of Voltage and current

3.2 Voltage Source Converters Used in UPFC

3.2.1 STATCOM

A static synchronous generator operated as a shunt – connected static var compensator whose capacitive or inductive output current can be controlled independent of the ac system voltage. For the voltage-sourced converter, its ac output voltage is controlled such that it is just right for the required reactive current flow for any ac bus voltage dc capacitor voltage is automatically adjusted as require serving as a voltage source for the converter. STATCOM also designed to act as an active filter to absorb system harmonics. Fig-4 shows the schematic diagram of STATCOM without energy storage system.

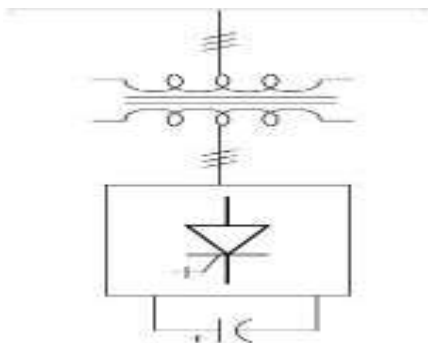

Fig – 4: schematic diagram of STATCOM without energy storage system

3.2.2 SSSC

A Static synchronous series generator operated without an external electric energy source as a series compensator whose output voltage is in quadrature with and controlled independently of the line current for the purpose of increasing or decreasing overall reactive voltage drop across the line and thereby controlling the transmitted electric power. The SSSC may include transiently rated energy storage or energy absorbing devices to enhance the dynamic behavior of the power system by additional temporary real power compensation to increase or decrease momentarily the overall real voltage drop across the line.

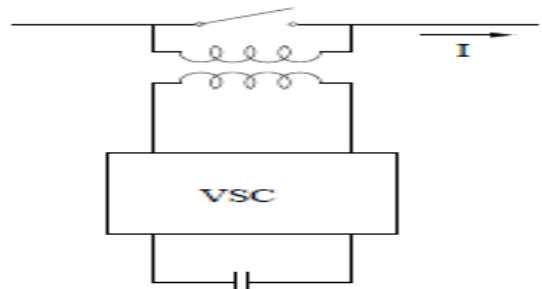

Fig – 4: Schematic of SSSC

4. Control of UPFC OPERATING MODES OF UPFC

As the UPFC consists of two converters that are coupled on the DC side, the control of each converter is explained below:

4.1 Control of the Shunt Converter:

The block diagram of shunt converter is shown in fig 5. The shunt converter draws a controlled current from the system. One component of this current is I_p which is automatically determined by the requirement to balance the real power supplied to the series converter through the DC link. This power balance is enforced by regulating the DC capacitor voltage by feedback control.

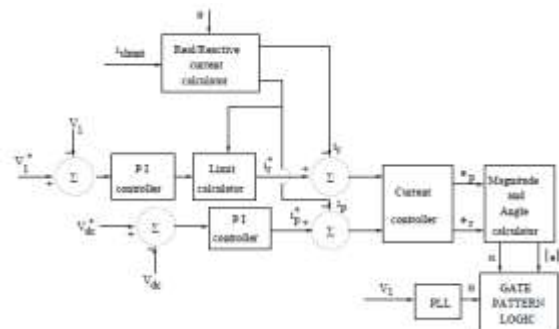

Fig – 5: block diagram of shunt controller

The other component of the shunt converter current is the reactive current, I_r which can be controlled in a similar

fashion as in a STATCOM. There are two operating (control) modes for a STATCOM or the shunt converter [17]. These are,

1. VAR control mode where the reactive current reference is determined by the inductive or capacitive VAR command. The feedback signals are obtained from current transformers (CT) typically located on the bushings of the coupling (step down) transformer.
2. Automatic voltage control mode where the reactive current reference is determined by the output of the feedback voltage controller which incorporates a droop characteristic (as in the case of a SVC or a STATCOM). The voltage feedback signals are obtained from potential transformers (PT) measuring the voltage V_1 at the substation feeding the coupling transformer.

4.2 Control of the series converter:

The block diagram of series converter is shown in fig-6. In this control mode, the series injected voltage is determined by a vector control system to ensure the flow of the desired current (phasor) which is maintained even during system disturbances (unless the system control dictates the modulation of the power and reactive power). Although the normal conditions dictate the regulation of the complex power flow in the line, the contingency conditions require the controller to contribute to system stability by damping power oscillations.

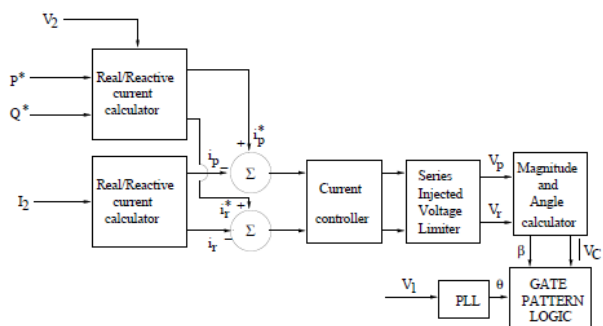

Fig - 6: block diagram of series controller

The different control modes for the series voltage are given:

1. Direct voltage injection mode where the converter simply generates a voltage phasor in response to the reference input. A special case is when the desired voltage is a reactive voltage in quadrature with the line current.
2. Phase Angle Shifter Emulation mode where the injected voltage is phase shifted relative to the voltage by an angle specified by the reference input.
3. Line impedance emulation mode where the series injected voltage is controlled in proportion to the line current.
4. Automatic power flow control mode where the reference inputs determine the required real power (P)

and the reactive power (Q) at a specified location in the line.

3. CONCLUSIONS

In this study, a brief review of UPFC (FACTS), the essential features of UPFC controller and mathematical model was discussed. The potential to enhancement of power system stability was explained. In power system transmission, it is required to maintain the voltage magnitude, phase angle and line impedance. Consequently, to control power flow over designated transmission line and enhancement of power system stability FACTS devices are used in modern power system network. The Comparisons of Facts Controller on different aspects are given in Table 1

In this paper the role of UPFC device in power system and current status of electric power system network are addressed. Therefore, following results are found power flow control is achieved by using FACTS (UPFC) devices. Transient stability is improved and faster steady state is achieved. Hence congestion is less by improving transient stability.

Table -1: Comparisons of Facts Controller

Facts devices	Power System Stability Enhancement	Load flow	Voltage Control	Transient Stability	Dynamic Stability
UPFC	Yes	High	High	Medium	Medium
TCSC	Yes	Medium	Low	High	Medium
SVC	Yes	Low	High	Low	Medium
SSSC	Yes	Low	High	Medium	Medium

REFERENCES

- [1] N. G. Hingorani and L. Gyugyi, "Understanding FACTS, Concepts, and Technology of Flexible AC Transmission Systems", Piscataway, N IEEE Press, 2000.
- [2] Mithu Sarkar, "Effect Of UPFC Allocation on Transmission System Power Loss", Int.Conf. On Energy Efficient Technologies for System Sustainability (ICEETS-2013), IEEE, Tamilnadu, 10th - 12th April 2013.
- [3] Gyugyi, L., Schauder, C.D., Williams, S.L., Reitman, T.R., Torgerson, D.R. and Edris, A. "The unified power flow controller: A new approach to power transmission control", IEEE Transaction Power Delivery, Vol. 10, pp. 1085-1097,1995.

- [4] AmlanBarik, SidharthSabyasachi, "Control Design and Comparison of Unified Power Flow Controller for Various Control Strategies" International Journal of Recent Technology and Engineering (IJRTE) ISSN: 2277-3878, Volume-3, Issue-1, March 2014.
- [5] Roopa. R, K.ShanmukhaSundar, "Enhancement Of System Performance Using Upfc",Irf International Conference, 05th July-2014, Bengaluru, India, Isbn: 978-93-84209-33-9.
- [6] Tanushree Kaul, Pawan Rana, "Modeling, Analysis and Optimal Location of UPFC for Real Power Loss Minimization", International journal application, 7 July 2013.
- [7] Sandeep Sharma and Shelly Vadhera, "Enhancement of Power Transfer Capability of Interconnected Power System Using Unified Power Flow Controller (UPFC)", International Journal of Electronics and Electrical Engineering Vol. 4, No. 3, June 2016.
- [8] A. Rajabi-Ghahnavieh, M. Fotuhi-Firuzabad, "UPFC for Enhancing Power System Reliability", IEEE-2010.
- [9] Kunal Gupta, Baseem Khan, "Available Transfer Capability Enhancement by Unified Power Flow Controller", IEEE - 2015.
- [10] Sadjad Galvani, MehrdadTarafdard Hagh, "Unified power flow controller impact on power system predictability", IEEE-2014.
- [11] H. E. Tooraji and N. Abdolamir, "Improving Power Quality Parameters in AC Transmission Systems Using Unified Power Flow Controller," Research Journal of Recent Sciences, Vol.2, No.4, pp.84-90, Apr. 2013.
- [12] K. Gaurav and N. Saxena, "Power Quality improvement using UPFC," International Journal of Electrical, Electronics and Computer Engineering, Vol.2, No.2, pp.30- 33, 2013.
- [13] S. Vaibhav Kale, R. P.Prashant and R. Khatri, "Unified Power Flow Controller for Power Quality Improvement," International Journal of Emerging Science and Engineering (IJESE), Vol.1, No. 10, pp. 1-4, Aug. 2013.
- [14] K. S. Lakshmi, G. Sravanthi, L. Ramadevi, and K. H. Chowdary, "Power quality and stability improvement of HVDC transmission System using UPFC for Different uncertainty conditions," International Journal of Scientific & Engineering Research, Vol. 6, No. 2, pp. 795-801, Feb. 2015.
- [15] M. S. Soruban, J D. Sathyaraj, and J. J. Gnana Chandran, "Power Quality Enhancement Using UPFC as an Active Power Filter for Renewable Power Generation," International Journal of Advanced Research in Electrical, Electronics and Instrumentation Engineering Vol. 4, No. 3, pp. 1712-1718, March. 2015.