

EXPERIMENTAL INVESTIGATION ON SEISMIC RETROFITTING OF RCC STRUCTURES

Jansi Rani K¹, Subathra.S², Sekar. A³

¹Post Graduate Student, Structural Engineering, New prince Bhavani College of Engg & Tech, Tamil Nadu, India

²Asst professor, Dept of Civil Engg, New prince Bhavani College of Engg & Tech, Tamil Nadu, India

³Head of Department, Dept of Civil Engg, New prince Bhavani College of Engg & Tech, Tamil Nadu, India

Abstract - Beam-column joints are recognized as the critical and vulnerable zone of a Reinforced Concrete (RC) moment resisting structure subjected to seismic loads. During an earthquake, the global response of the structure is mainly governed by the behavior of the joints. If the joints behave in a ductile manner, the global behavior generally will be ductile, whereas if the joints behave in a brittle fashion then the structure will display a brittle behavior. The joints of old and non-seismically detailed structures are more vulnerable and behave poorly under the earthquakes compared to the joints of new and seismically detailed structures. Therefore, the joints of such old structures require retrofitting in order to deliver better performance during earthquakes. This paper reports a experimental investigations carried out for seismic retrofitting of RC beam-column joints using concrete jacketing. The seismic rehabilitation process aims to improve seismic performance and correct the deficiencies by increasing strength, stiffness or deformation capacity and improving connections. The present study focuses on the behavior of reinforced concrete beam-columns strengthened using concrete jacketing subjected to cyclic loading

Key Words: Seismic, Retrofit, Jacketing, strengthening, ductility.

1. INTRODUCTION

Reinforced concrete (RC) structures designed only for gravity loads proved their performance under conventional gravity loads. However, their performance is questionable under seismic-type loading; the facts are witnessed by the structural failures observed during earthquakes worldwide. Observation of the damage caused by strong earthquakes has highlighted the typical collapse mechanism of structural elements. Hence, both for existing structures and newly designed structures, a structural mechanism has to be evolved in a way so that the seismic energy introduced into the structure must be dissipated within the structure. Energy dissipation takes place mainly through inelastic behavior of the structural system since the structure must be damaged to dissipate energy. If seismic energy is dissipated at locations that make the structure unable to satisfy the equilibrium of forces, collapse is inevitable. Generally for avoiding any collapse in column or in joint, a commonly termed "strong column-weak beam" concept is followed over "strong beam-weak column"

concept. Post earthquake examination shows that one of the weakest links in the lateral load resisting system is the beam-column joints, especially exterior ones because of a sudden geometric discontinuity and also they are not confined by beams from all the sides. The beam-column joints with inadequate or no transverse shear reinforcement have proved deficient and are likely to experience brittle shear failure during earthquake motions. Strengthening of RC beam-column joints has received much attention during the past two decades. Seismic retrofitting of reinforced concrete structures is aimed at strengthening structures, in general, and components, in particular, to achieve more and consistent strength ductility and energy dissipation. Numerous researches carried out on different retrofit techniques including the use of concrete jackets, bolted steel plates, and FRP sheets, were considered in the structural upgrading, especially for columns and beam-column joints in the moment-resisting frames. The purpose of the rehabilitation is to prevent columns or joints from a brittle shear failure, and shift the failure towards a beam flexural hinging mechanism, which is a more ductile behavior.

2. LITERATURE REVIEW

Giuseppe Oliveto And Massimo Marletta (2005)[1] considered the retrofitting of buildings vulnerable to earthquakes and briefly described the main traditional and innovative methods of seismic retrofitting. Among all the methods of seismic retrofitting, particular attention was devoted to the method which was based on stiffness reduction. This method was carried out in practice by application of the concept of springs in series, which lead in fact to base isolation. One of the two springs in series represented the structure and the other represented the base isolation system. The enhanced resistance of the buildings to the design earthquake clearly showed the effectiveness of the method, while a generally improved seismic performance also emerged from the application.

Yogendra Singh (2003)[2] large number of existing buildings in India is severely deficient against earthquake forces and the number of such buildings is growing very rapidly. This has been highlighted in the past earthquake. Retrofitting of any existing building is a complex task and requires skill, retrofitting of RC buildings is particularly challenging due to complex behaviour of the RC composite

material. The behaviour of the buildings during earthquake depends not only on the size of the members and amount of reinforcement, but to a great extent on the placing and detailing of the reinforcement. The construction practices in India result in severe construction defects, which make the task of retrofitting even more difficult. Step to step procedure given below-

- Setting of goals and performance level of building and estimation of seismic hazard.
- Systematic visual inspection and study of available drawing and documents.
- In situ investigation for strength and degradation of material and preparation of as built drawing.
- Identify deficiencies and scheme for detailed investigation.
- Detailed evaluation of strength, ductility, deterioration.
- Design of Retrofitting scheme based on evaluated deficiencies.
- Evaluation of Retrofitted building.

Pampanin and Christopolos [3,4], panel zone of the joints was protected by migrating the plastic hinge some distance away from the face of the column and by redirecting the beam shear forces to the column through axial straining of the haunch. The method causes a decrease of the maximum drift in the structure.

Shafaei et al. [5,6] suggested a retrofit method for concrete joint reinforced by deformed bars. In this method, the connection area was strengthened by steel angles prestressed by cross ties where stiffeners were welded to the angles. The proposed method shows significant enhancement of the seismic capacity of the joints, in terms of strength, stiffness, energy dissipation and ductility. Also the technique improved the bond between longitudinal reinforcement and concrete in the joint.

The behaviour of FRP wrapped concrete cylinders with different wrapping materials and bonding dimensions has been studied by **Lau and Zhou [7]** using the finite element method (FEM) and other analytical methods. It was found that the load-carrying capacity of the wrapped concrete structure is governed by mechanical properties such as tensile elasticity modulus and Poisson's ratio of the wrapping sheet.

Zhao and Feng (2003) [8], investigated experimentally the seismic strengthening of RC columns with wrapped CFRP sheets. The ductility enhancement with the confinement of CFRP sheets was studied by the strain development and distribution in the CFRP sheets. Based on the experimental results, a confinement factor of CFRP and an equivalent transversal reinforcement index were suggested. In spite of the extensive work on reinforced concrete columns, very few researchers have worked on reinforced concrete columns strengthened using FRP subjected to reversed cyclic loading.

Experimental Program of Beam Column Joint on Concrete Jacketing

Description of the Specimen

A typical beam-column joint with detailing as per IS 456:2000 (IS 2000) was scaled down to laboratory conditions. The specimens were subjected to reverse cyclic loading and their performance was examined for lateral load capacity. The specimens were classified into two types. Type 1, the Control Specimens (CS), was cast with transverse reinforcement detailing as per IS 456:2000 and SP 16: 1980 (IS 1980) representing non ductile joint. Type 2, conventionally Retrofitted Specimen (CR).

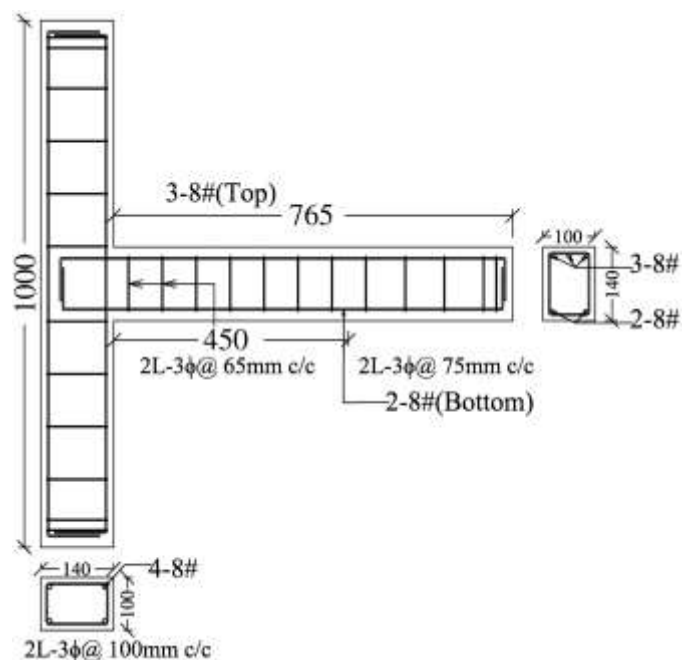

Fig-1: Dimension and reinforcement details of control specimens (CS)

The column was rectangular in shape with dimensions 100 × 140 mm and the beam with dimensions 100 × 140 mm with an effective cover of 15 mm in all specimens. A 30 mm concrete jacket over a length of 450 mm on the column and 250 mm on the beam is provided. The concrete jacket was provided as per the guidelines given in Arya and Agarwal (2009). Ties with 135° hooks [as per guidelines IS 13920:1993 (IS 1993)] were provided in the concrete jacketing region as shown in Fig 2.

Preparation of Specimen

The specifications of the materials used to cast the specimens are as follows: The cement used was Portland Pozzolona cement (fly ash based) conforming to IS 1489:1991 (Part 1) (IS 1991). Manufactured sand (M-sand) conforming to zone II as per IS 383:1970 (IS 1970) was used as fine aggregate. Crushed granite stone of maximum size not exceeding 8 mm was used as coarse aggregate. The mix

design was carried out as per IS 10262:2009 (IS 2009). The mix proportion was 1:1.569:2.769 by weight and the water cement ratio was kept as 0.40. The 28-day average compressive strength from 150 mm cube test was 34.15 N/mm². High yield strength bars were used as longitudinal reinforcement and ties. The yield stress of reinforcement was 432 N/mm². All the specimens were cast in horizontal position inside a steel mold. For jacketing the retrofitted specimens, the surface of two control specimens were cleaned for removal of dirt, had their sharp edges chipped off, and their surfaces roughened for facilitating bonding between old and new concrete as shown in Fig. 4. A reinforcement cage was placed around the joint region. The entire assembly was positioned inside steel mold for concreting. Retrofitted (Fig. 4) specimens were cast simultaneously with the same mix for better comparison of performance. Specimens were demolded after 24 h and then cured in curing tank for 28 days.

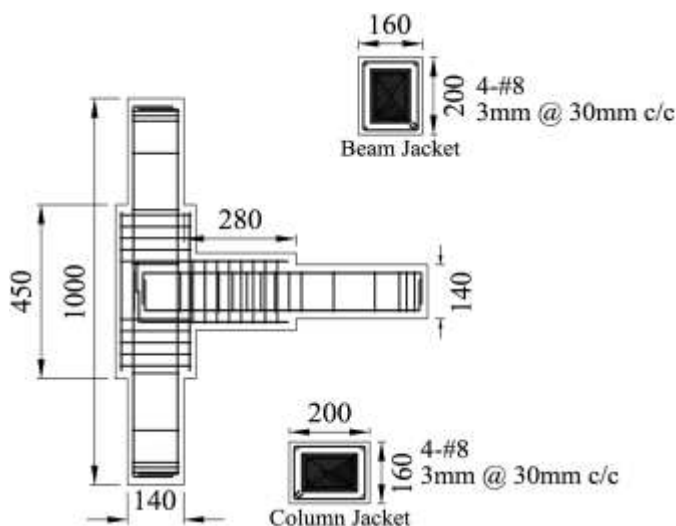

Fig-2: Dimension and reinforcement details of conventionally retrofitted specimens (CR)

Test Setup and Instrumentation

The test setup in the Laboratory is shown in Fig. 5. The column was mounted vertically with the hinged supports at both upper and lower ends, which were tightly fastened to the testing frame by two MS clamps using bolts. Cyclic loading was applied by two 196.20 kN (20 t) hydraulic jacks, one kept fixed to top of the loading frame and the other to the bottom of the loading frame. Reverse cyclic load was applied at 75 mm from the free end of the beam portion of the assemblage. A schematic diagram of the test setup is shown in Fig. 6. The test was load-controlled and the specimen was subjected to an increasing cyclic load up to failure. The load increment chosen was 1.962 kN (0.2 t). The specimen was first loaded up to 1.962 kN and unloaded and then reloaded on the reverse direction up to 1.962 kN. The subsequent cycles were also loaded in a similar way. Fig. 7 shows the loading sequence of the test assemblages. To

record loads precisely, load cell with least count 0.981 kN (0.1 t) was used. The specimens were instrumented with Linear Variable Differential Transducer (LVDT, SYSCON Instruments, Bangalore) having least count 0.1 mm to measure the deflection at the loading point. MS plates were provided at the point of loading to avoid local crushing of concrete. A computer-based data acquisition system was used for capturing data.



Fig- 3: Casting of control specimens (CS)



Fig-4: Casting of retrofitted specimen



Fig-5: Test setup in the laboratory

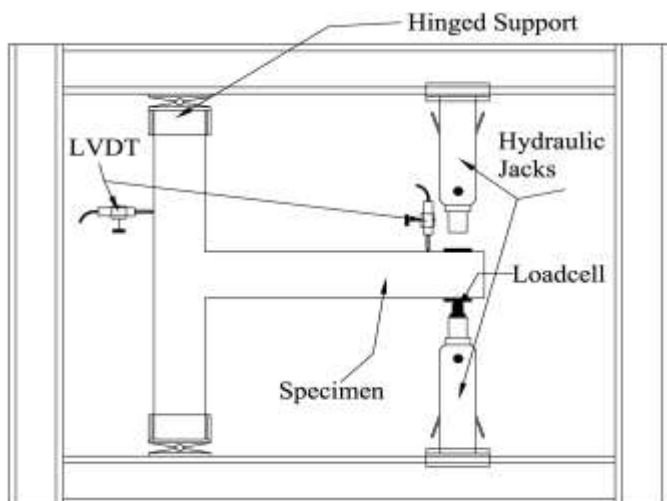

Fig-6: Schematic diagram of test setup



Fig-7: Sequence of cyclic loading

Results and Discussion

The test results are presented in the form of load-deformation hysteretic curves, load-deformation envelope curves, energy dissipation charts, and ductility charts. The observations during the test are briefly described.

Cracking Patterns and Failure modes

Figs. 8,9 show the crack patterns and failure modes of the tested specimens. The failure of nonductile control specimens were characterized by the formation of cracks near the joint. The first crack occurred at beam-column joint at third loading cycle when the load reached 5.886 kN in both positive and negative cycle of loading. The initial diagonal hairline crack on the joint occurred at the fourth cycle of loading when the load reached 7.848 kN in both positive and negative cycles. The specimens failed due to the advancement of crack width at the interface between beam and column and X-shaped cracks in the joint region. The concrete wedge mechanism was also observed, i.e., concrete at the rear side of column became detached in a wedge

shape. The X-shaped cracks are due to the absence of stirrups in the joint region, and the detachment of concrete



Fig.-8: Failure pattern of control specimen (CR)



Fig-9: Failure pattern of conventionally retrofitted specimen

wedge was due to inadequate development length of beam bars at joint. The retrofitted and monolithically jacketed specimens performed better in terms of ultimate load carrying capacity, energy dissipation, and ductility. In retrofitted specimens, the cracking occurred in the beam at the interface of jacket, which shows the shifting of plastic hinge formation beyond the joint region. The cracking patterns in the strengthened specimens were similar and also have better performance than that of the control specimen. The first crack itself occurred in the beam only at 6th cycle, which was at 4th cycle in joint region for the control specimen. The cracking started at jacket face on the beam and cracks widened further as the load increased. At the ultimate load, the failure occurred in the beam and also minor cracks developed in the jacket. Thus, it is evident that the concrete jacketing around joint region is capable of transferring the failure to the beam, thus exhibits an appreciable seismic behaviour through plastic hinge formation in the beam.

Ultimate Load Carrying Capacity

Based on the experimental results, the ultimate load carrying capacity of retrofitted specimens is found higher than that of control specimens, as shown in Table 1. The control specimens sustained an ultimate load of about 9.81 kN. The retrofitted specimens with the conventional ties in the concrete jacket (CR) was capable of attaining higher values of ultimate load carrying capacity, i.e., loads 1.40 times of the control specimens.

Energy Dissipation

As a measure of the dissipated energy of the specimens, the area under the load displacement curves for all cycles were computed and called as energy that could be dissipated by the specimens before the specimen lost its stability. In the evaluation of earthquake resistance, energy dissipation capacity of a structure is traditionally associated with the shape of the load displacement hysteretic loops Figs. 10–11 represent the hysteresis loop for all the specimens. Table 2 shows the average energy dissipation capacity in upward and downward loading for the tested specimens. It is evident that the energy dissipation of retrofitted specimens exhibited energy dissipation values of 2.97 times that of the control specimens

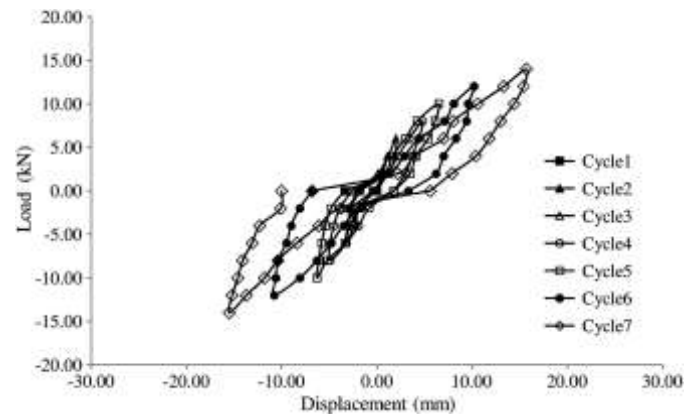

Fig.-11: Hysteresis curves for retrofitted specimen (CR)

specimen	Energy dissipation capacity in kNmm			Increase in energy dissipation capacity
	Downward direction	Upward direction	Average	
CS	113.60	103.72	108.66	-
CR	222.37	217.13	220.25	2.02

Table -2: Energy Dissipation Capacity for Tested Specimens

Specimen	Yield Load			Ultimate Load			% increase
	Downward direction	Upward direction	Average	Downward direction	Upward direction	Average	
CS	7.85	7.85	7.85	9.81	9.81	9.81	-
CR	10.99	10.99	10.99	13.73	13.73	13.73	40

Table-1: Ultimate Load Carrying Capacity of Test Specimens

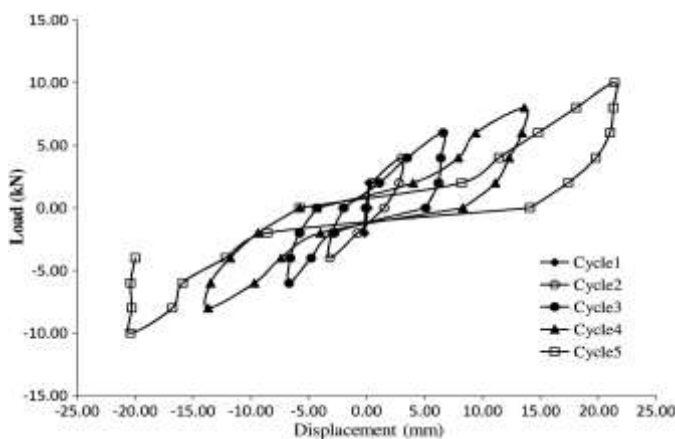

Fig.-10: Hysteresis curves for control specimens (CS)

Displacement Ductility

The displacement ductility is the ratio between the maximum and yield displacement for each specimen, determined from the load displacement envelope curves. The displacement ductility values for control specimens are lower and resulted in poor seismic performance. This is due to the non optimal reinforcement details and absence of shear reinforcement in the joint region. The upgraded specimens show better seismic performance in terms of displacement ductility, which is due to the increased concrete section and additional reinforcement around joint region. Retrofitted specimens CR show a ductile performance with displacement ductility values 84.32 higher than that of the control specimens.

3. CONCLUSIONS

Based on the experimental results in the present study, the following conclusions can be drawn:

1. In the non ductile beam-column joints, the diagonal cracks were developed in the joint region leading to global failure of the structure.
2. The specimen with conventional retrofitting (CR) shows 40, 103, and 84% increases in ultimate load, energy dissipation, and displacement ductility, respectively, compared with the control specimen (CS).

REFERENCES

- [1] Giuseppe Oliveto, Massimo Marleta, (2005), seismic retrofitting of reinforced concrete buildings using traditional and innovative techniques, ISET journal of earthquake technology, 42(2-3), pp 21-46.
- [2] Yogendra Singh, (2003), "Challenges in retrofitting of RC buildings", Workshop on retrofitting of structures IIT Roorkee, pp 29-44.
- [3] Pampanin S, Christopoulos C, Chen TH. Development and validation of a metallic haunch seismic retrofit system for existing under-designed RC frame buildings. J Earthquake Eng & Struct Dyn 2006; 35:1739–66.
- [4] Genesio G, Eligehausen R, Pampanin S. Application of post-installed anchors for seismic retrofit of RC beam-column joints: design method. In: Proceedings of the Ninth Pacific conference on earthquake engineering, building an earthquake-resilient society, Auckland, New Zealand, 2011.
- [5] Shafaei J, Hosseini A, Marefat M. Seismic retrofit of external RC beam-column joints by joint enlargement using prestressed steel angles. J Eng Struct 2014;81:265–88.
- [6] Shafaei J, Zareian M, Hosseini A, Marefat M. Effects of joint flexibility on lateral response of reinforced concrete frames. J Eng Struct 2014; 81:412–31.
- [7] Lau, K. T.; Zhou, L. M. (2001). The mechanical behaviour of composite-wrapped concrete cylinders subjected to uniaxial compression load, *Composite Structures* .52: 189–198.
- [8] K. Zhang et al. (2003). Experimental study on seismic strengthening of RC columns with wrapped CFRP sheets. *Construction and Building Materials*, 499-506.