

# Power Quality Improvement by Harmonic Reduction using Compact Design Multilevel Inverter for Renewable Energy Sources

Aboli R. Patil<sup>1</sup>, Prof. Prasad Kulkarni<sup>2</sup>

<sup>1</sup>M. Tech. Student, Electrical Engineering Department & KCE College of Engineering, Jalgaon (MS)

<sup>2</sup>HoD, Electrical Engineering Department & KCE College of Engineering, Jalgaon (MS)

\*\*\*

**Abstract** - New construction electrical converter with reduced variety of power switches is projected. This new construction electrical converter supported cascaded Improved H-bridge topology provides easier structure and reduced total harmonic distortion (THD) as we tend to increase numbers of output signal levels of electrical converter. This paper describes a replacement idea of shift with reduced variety of switches and batteries. This idea helps to scale back the quality of shift compared to alternative construction inverters. Projected construction electrical converter having twenty one level output is valid with an easy resistive load through simulation in MATLAB simulink 2018a.

**Key Words:** Cascaded H-Bridge, 21 level Converter.

## 1. INTRODUCTION

This day's multilevel inverters became common thanks to their ability in voltage function and performance. The multilevel electrical converter is obtained the desired output by using several independent sources of dc voltage. The electrical converter voltage output wave form is obtained nearly sinusoidal wave form with AN increasing variety of dc sources by employing a switching frequency [1]. It shows low switching losses and low voltage stress as a result of many dc sources. Low output of Electro Magnetic Interference (EMI), it shows far above the ground potency and low switching losses and high voltage operation capability and additional operation still receive multilevel inverters. The word multilevel starts with associate three-level electrical converter [2]-[5].

In Power electronic applications, multilevel inverters are getting widespread, as multilevel inverters have the nice ability to satisfy the a lot of demand of power rating and power quality related to reduced range of harmonic distortion and lesser electromagnetic interference. In high switching frequency pulse width modulation (PWM), of multilevel electrical converters has many benefits over a traditional two-level inverter [6]. The lot of engaging options of a multilevel electrical converter is as follows:

1. The output voltage will produce by near to the ground distortion and DV/DT stress.
2. The input current is drained by near to the ground distortion.
3. The common mode voltage is extremely tiny.

4. It works on small switching frequency.

Multilevel inverters are prearranged with the help of power switching devices and capacitor voltage sources. It's appropriate for top voltage applications and voltage waveforms due to their capability to calculate output voltage with higher harmonics to achieve high voltages with most device rating. The major sorts of multilevel inverters are tumbled H-bridge, diode clamped and capacitor clamped electrical converter. It needs less variety of parts in every level capacitor and switches additionally less number of a cascaded H-bridge electrical converter.

This kind consists of series power transfer cells and power will simply obtain. In multilevel inverters tumbled H-bridge it suggests the break up input dc voltage by the mixture of capacitors and switches [11]. It consists of H-bridge cells and every cell will offer the 3 completely unlike voltages similar to zero, positive DC and negative DC voltages. The main advantage of this multilevel electrical converter that wants less variety of parts compared to the opposite 2 types. The value and weight of the electrical converter is a smaller amount compared to the opposite 2 types. Soft-switching is feasible to get the new switching methods[7]. Multilevel cascade inverters are accustomed eliminate the harmonics of Total Harmonics Distortion and also the transformer needed in case of standard point inverters, clamping diodes needed just in case of diode connected inverters and flying capacitors desired in case of flying capacitor inverters. If the supply of every cell need sizable amount of isolated voltage and compare to the 2 types[8]. The planned structure electrical converter Topology has a lot of benefits than the present topologies because the variety of switching devices and Total Harmonic Distortion are reduced[9]-[10]. So the switching losses are reduced, increasing a potency of the output. The planned structure electrical converter needs less number of switches and high potency and fewer numbers of losses. Pulse width Modulation (PWM) methods are currently wide used because of their reduced process demand, simplicity and strength [12]

This paper organized as follow in section 2 literature review is enclosed for the 2 necessary types of MLI 1) Symmetrical Cascaded H Bridge multilevel electrical converter 2) Asymmetrical Cascaded H Bridge multilevel electrical converter. Section 3 contains projected MLI with the assistance of diagram, circuit diagram description and results and result comparison last section concluded our work

## 2. LITERATURE SURVEY

### a. Symmetrical Cascaded H Bridge Multilevel Inverter

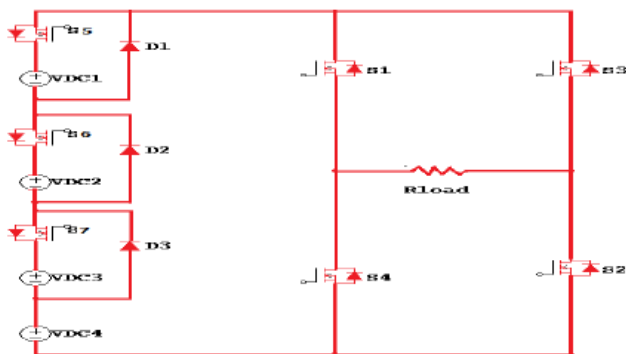

Fig -1: Symmetrical Cascaded H Bridge Multilevel Inverter

Figure 1 represents the Symmetrical Cascaded H Bridge electrical converter (SCHB-MLI) topology. In this Circuit, once MOSFET Controlled Switch is Turned On, the DC Voltage supply and MOSFET Controlled Switch are connected nonparallel, in order that the current flows from DC supply to MOSFET and also the Diode becomes Reverse biased Condition. When

MOSFET controlled Switch is turned OFF, the current flows via diode and therefore the diode is forward biased. The Circuit desires four DC voltage sources, twenty four switches and ten DC sources are equal with Voltage of 230 VDC, and this circuit can generate twenty one Level output voltage of 230VDC, 207VDC, 184VDC, 161VDC, 138VDC, 0VDC, -23VDC, -46VDC, -69VDC, -92VDC respectively. [2]

Table-1: The Switching Configuration of Symmetrical 9 Levels CHBMLI

$V_0$	$S_1$	$S_2$	$S_3$	$S_4$	$S_5$	$S_6$	$S_7$
$V_{dc}$	ON	ON	OFF	OFF	ON	ON	ON
$3V_{dc}/4$	ON	ON	OFF	OFF	OFF	ON	ON
$2V_{dc}/4$	ON	ON	OFF	OFF	OFF	OFF	ON
$V_{dc}/4$	ON	ON	OFF	OFF	OFF	OFF	OFF
0	OFF	ON	ON	OFF	OFF	OFF	OFF
$-V_{dc}/4$	OFF	OFF	ON	ON	OFF	OFF	OFF
$-2V_{dc}/4$	OFF	OFF	ON	ON	OFF	OFF	ON
$-3V_{dc}/4$	OFF	OFF	ON	ON	OFF	ON	ON
$-V_{dc}$	OFF	OFF	ON	ON	ON	ON	ON

In SCHBMLI the total Number of switches and the output voltage levels are obtained as follows

$$N_{Levels} = 2n + 3 \quad \dots (1)$$

$$N_{mosfet} = n + 4 \quad \dots (2)$$

The 'n' represents the number of MOSFET in Symmetrical unit Circuit.

### b. Asymmetrical Cascaded H Bridge Multilevel Inverter

In Asymmetrical Cascaded H Bridge electrical converter (ASCHB-MLI) topology this electrical converter the DC supply magnitudes aren't constant. The DC supply magnitudes are supposed with binary kind of voltage like 25VDC, 50VDC, 100VDC correspondingly. Along the electrical converter consists of same amount of Power semiconductor switches however the voltage level varies. In SCHBMLI the output voltage is 9level, wherever as in ASCHBMLI the output voltage is fifteen level and that they are 33Vdc, 66Vdc, 99Vdc, 132Vdc, 165Vdc, 198Vdc, 231Vdc, 0Vdc, -33Vdc, -66Vdc, -99Vdc, -132Vdc, -165Vdc, -198Vdc, -231Vdc respectively.[3]-[4]

In ASCHMLI the number of switches and number of levels are represented as follows [6]-[7]

$$N_{Levels} = 2[n + 1] - 1 \quad \dots (1)$$

$$N_{mosfet} = n + 4 \quad \dots (2)$$

The 'n' represents the number of MOSFET in Symmetrical unit Circuit.

## 3. PROPOSED MULTILEVEL INVERTER (21 LEVELS)

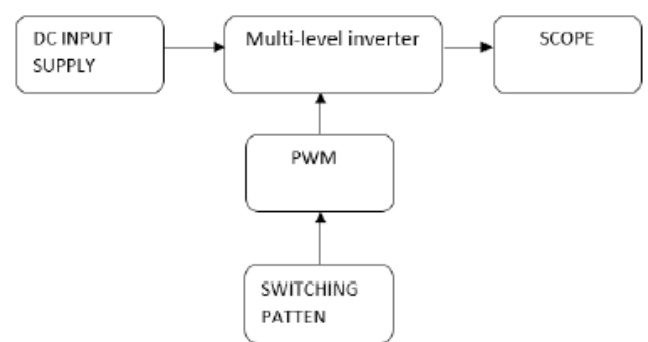

Fig -2: Block diagram of proposed inverter

Figure two shows blocks of planned twenty one multilevel electrical converter circuit to realize planned goal total twenty four switches are employed in the logic circuit as shown in figure 3, there's cascaded ten stages are used and output of cascaded ten stages is given the bridge circuit then load is connected to the bridge For the simulation purpose individual pulse generator block is employed to get dominant pulses.

The planned topology is simulated in MATLAB. It consists of 4 front end MOSFETS (S1-S20) that are connected with a single phase voltages rating  $V1=23V$ ,  $V2=23V$ ,  $V3=23V$  then on. It conjointly consists of 4 MOSFETs that are connected in an H-bridge model as shown within the circuit. The switching pulses are connected to the H bridge circuit by conventional curving pulse width modulation technique (for the production of positive and negative oscillation). The switching pulses intended for the frontend MOSFETs are particular by the binary priority encoder, These pulses are generated once the reference signal overlaps the carrier signals. The pulses are produced simultaneously with a delay which is specified to every switch. Frequency of the Reference sin waves fifty cycles/second and output of the carrier waves are concerning five kilocycle per second each. The resulting voltage and current waveforms of the twenty one levels MLI are shows the FFT analysis and therefore the Total Harmonic Distortion (THD) achieved is concerning 10.65% for no load voltage. The simulation circuit of planned multilevel electrical converter is shown as below figure three and figure five shows simulation output is carried out within the MATLAB. It's necessary to provide switching pulses to fourteen switches within the circuit -14(S1, S2 and S3 to S20) that manufacture the DC Link voltage and four (S21, S22, S23 and S24) within the H bridge electrical converter circuit. Same PWM methods are exercised here for each.

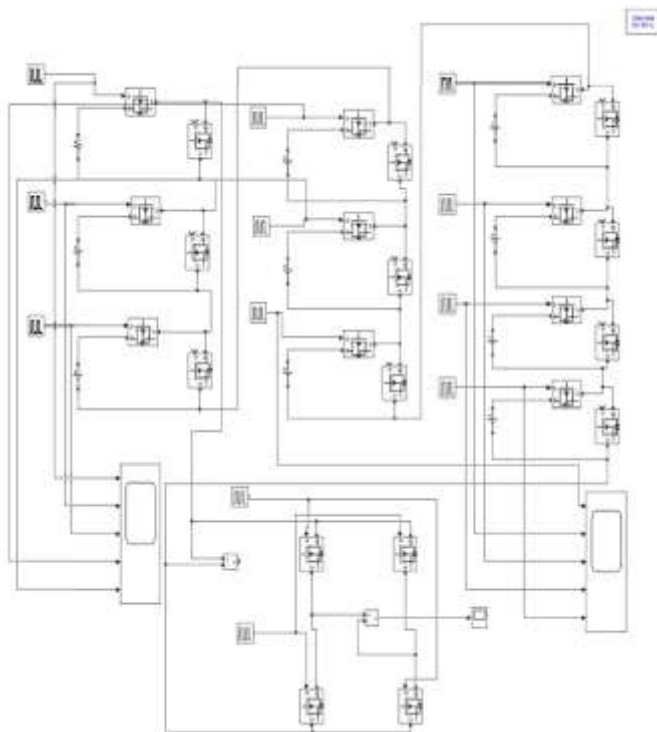

Fig -3: Circuit Diagram of Proposed Inverter

Total of 12 pulse generators are used to be in command of the MOSFETs as shown in figure 4, after verifying output waveforms of inverter on oscilloscope connected to the bridge circuit and the pulses to the scope directly

connected to the pulse generator circuits. Finally FFT analysis is performed on the output waveforms to calculate Total Harmonics Distortion (THD). Obtained Out waveform is shown in figure 5 and figure 4 control pulses applied to the switches then figure 6 and figure 7 shows FFT analysis result.

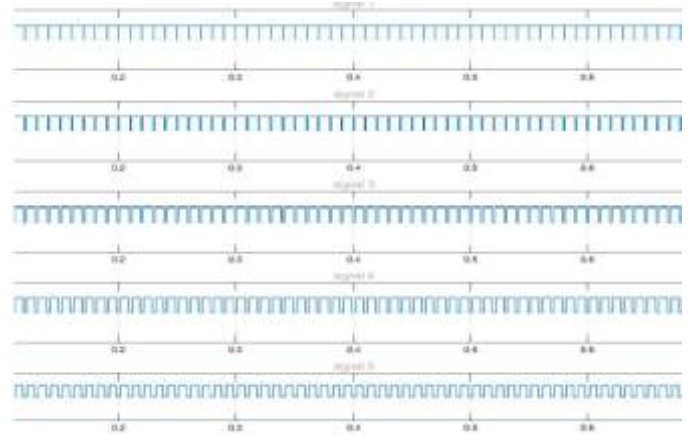

Fig -4: Some Selected control pulses used in circuit

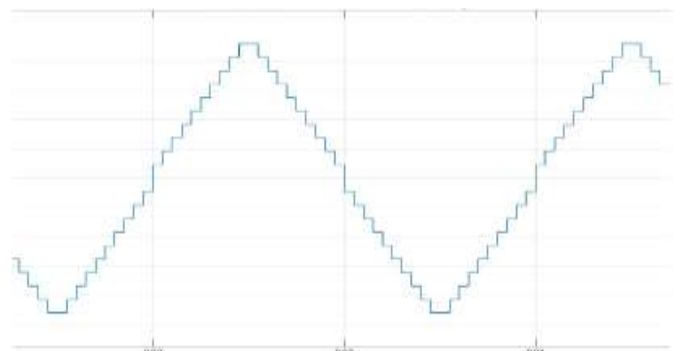

Fig -5: Out waveform of 21ML Inverter

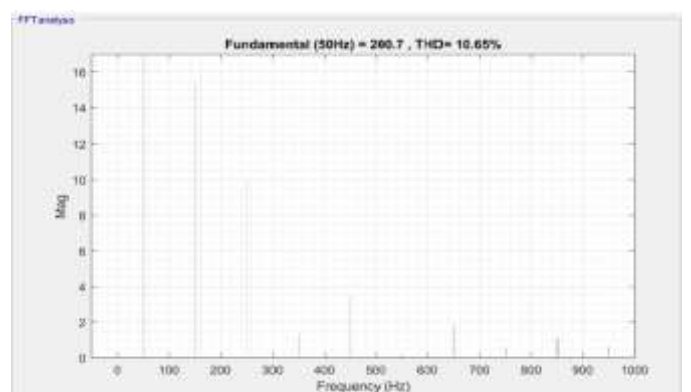

Fig -6: THD analysis of 21-level SCHBMLI with nyquist frequency

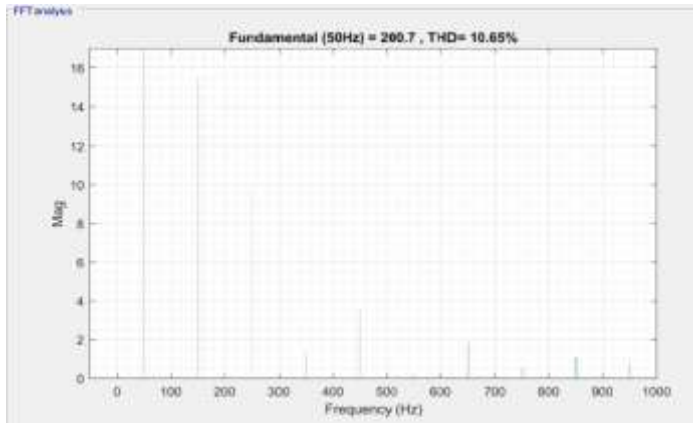

Fig -7: THD analysis of 21-level SCHBMLI with maximum frequency

### a. Result Comparisons

Chart shows result comparison our results with reference 12 level model, 7 level models and 9 level models. In a chart red line shows THD value obtained from simulating these three models in MATLAB simulink for 7 multilevel inverter total harmonic distortion value is highest which is 31.76% after that 9 multilevel inverter has lower value of THD as compared to 7 MLI that is 21.98% after that 12 multilevel inverter has lower value of THD as compared to 7 an 9 MLI that is 21.83 last but best our proposed MLI provides lowest value of THD as compared to all the MLI in this paper that is 10.65 these values are verified on MATLAB simulink 2018a. Chart clearly shows that as you increase output levels of MLI THD decreases.

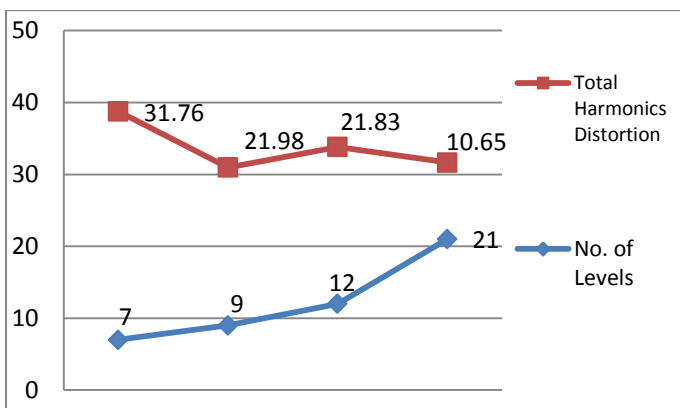

Chart-1: Result Comparisons with 5, 7 and 9 level models

### 4. CONCLUSION

Multilevel concept provides an efficient reduction of total harmonic distortion. The benefits of multilevel converter include lower transient power loss due to low frequency switching, reduced ac filters and thereby providing compact power conversion. High power high voltage tumbled multilevel inverter among corresponding DC voltage sources was projected and demonstrated in this paper. A whole simulation replica of a tumbled multilevel

inverter have been proposed utilizing MATLAB/Simulink programming output waveforms are processed for the THD analysis from the analysis we have results such for 7, 9, 12 and 21 we have THD values such as 31.76%, 21.98%, 21.83% and 10.65%. With the help of above work and results of our work we have concluded that if we want more harmonic free output then you have to increase output signal levels of multilevel inverter,

### ACKNOWLEDGEMENT

We thank our colleagues from KCE College of Engineering, Jalgaon (MS). Who provided insight and expertise that greatly assisted the research, we thank srikanth dakoju and Balraj for sharing their simulation files with MATLAB simulink because of without comparing obtained result of proposed method with their result it's difficult to calculate best part of our design, and Prof. Kulkarny for comments that greatly improved the manuscript. We would also like to show our gratitude to the principal of our college for sharing their pearls of wisdom with us during the course of this research,

### REFERENCES

- 1) Patil Swapnil Sanjay, Patil Rupali Tanaji and Patil S. K., "Symmetrical Multilevel Cascaded H-Bridge Inverter Using Multicarrier SPWM Technique", 2018 3rd International Conference for Convergence in Technology (I2CT), Page no: 1-4, IEEE, 2018.
- 2) Sumit Kumar and Dr. Yash Pal, "A Three-phase Asymmetric Multilevel Inverter for Standalone PV Systems", 6th International Conference on Signal Processing and Integrated Networks (SPIN), Page no: 357-360, IEEE, 2019.
- 3) Atmanandmaya and Dr. Jayaram Nakka, "Single Carrier PWM Scheme for Single Phase Nine Level Symmetrical Inverter for Renewable Energy Interfacing", Proceedings of 2018 International Conference on Emerging Trends and Innovations in Engineering and Technological Research (ICETIETR), Page no: 1-6, IEEE, 2018.
- 4) Nabil Farah and "Cascaded Multilevel Inverter With PV System", <https://www.researchgate.net/publication/289519952>, ResearchGate, Page No:1-43, Thesis, June 2015.
- 5) Sze Sing Lee, Michail Sidorov, Nik Rumzi Nik Idris, and Yeh En Heng, "A Symmetrical Cascaded Compact-Module Multilevel Inverter (CCM-MLI) with Pulse Width Modulation", IEEE Transactions On Industrial Electronics, 2017 IEEE.
- 6) Tapas Roy and Saikat Kumar Maity, "A Study of Symmetrical and various Asymmetrical DC Source Configurations of a Novel Cascaded Multilevel Inverter Topology", Conference on Technologies for Smart-City Energy Security and Power, March 28-30, 2018, Bhubaneswar, India. IEEE, March 2018.
- 7) Ch. Punya Sekhar, Dr. P. V. Ramana Rao and Dr. M. Uma Vani, "Novel Multilevel Inverter With Minimum Number Of Switches", bConference on Recent Trends in

- Electrical, Electronics and Computing Technologies,  
Page No: 106-112, IEEE, 2017.
- 8) Kishor Thakre, Kanungo Barada Mohanty, Ashwini Ku. Nayak and Rabi Narayan Mishra, "Design and Implementation of Symmetric and Asymmetric Structure for Multilevel Inverter", National Power Electronics Conference (NPEC) COEP Pune, India. Dec 18-20, page No: 31-36, IEEE, 2017.
  - 9) Minakshi Devi, Ameen Uddin Ahmad, "Review of Multilevel Inverters - Topologies, Control Techniques and Reduction of Leakage Current in Cascaded Multilevel Inverter", Enhanced Research in Science, Technology & Engineering journal, Vol. 4 Issue 9, Page no: 149-155, September-2015.
  - 10) Ibrahim Haruna Shanono, Gaddafi Sani Shehu, Abdullahi Bala Kunya and Tankut Yalcinoz, "A Review of Multilevel Inverter Topology and Control Techniques", Automation and Control Engineering journal, Vol. 4, No. 3, page no: 233-241, June 2016.
  - 11) Sanu Thomas P and Arun Xavier, "Cascaded H Bridge Fifteen Level Inverter", Engineering Research & Technology International Journal (IJERT), Page No: 881-883, Vol. 4 Issue 09, September-2015.
  - 12) M. N.Rao and Amol K. Koshti, "A Brief review on multilevel inverter topologies", International Conference on Data Management, Analytics and Innovation (ICDMAI), Feb 24-26, 2017.
  - 13) Anjali Krishna R and Dr L Padma Suresh, "A Brief Review on Multi Level Inverter Topologies", International Conference on Circuit, Power and Computing Technologies, IEEE, 2016.