

Overview of Pretreatment Process in powder coating

Priyanka Tupe¹, Meeta Thorat², Mr. Lashman K.³

¹Student, M.Tech (EDT), National Institute of Electronics & Information Technology, Aurangabad, Maharashtra, India

²Student, M.Tech (EDT), National Institute of Electronics & Information Technology, Aurangabad, Maharashtra, India

³Scientist D, National Institute of Electronics & Information Technology, Aurangabad, Maharashtra, India

Abstract - Pretreatment is a process that your manufacturer goes through to remove all grease, oils and dirt from the AL & MS surface. They need to do this before painting or powder coating to strengthen adhesion. We need to monitor all the process for better quality of product. We have monitored and automated the whole process through IOT. In industry pretreatment is the important process before powder coating. With this technology we can monitor the usage of materials and chemicals in future.

The whole procedure of pretreatment, we have done automation of it by using IOT technology. We have used esp8288 nodemcu which is reliable and easy to use.

Keywords: Pretreatment process monitoring, IOT technology, esp8266nodemcu

1. INTRODUCTION

Powder coating is a type of coating that is applied as a free-flowing, dry powder. The main difference between a conventional liquid paint and a powder coating is that the powder coating does not require a solvent to keep the binder and filler parts in a liquid suspension form. The coating is typically applied electrostatically and is then cured under heat to allow it to flow and form a skin. The powder may be a thermoplastic or a thermoset polymer. It is usually used to create a hard finish that is tougher than conventional paint. Powder coating is mainly used for coating of metals, such as household appliances, aluminum extrusions, drum hardware and automobile and bicycle parts.

1.1 PROPERTIES OF POWDER COATING

Powder coating does not have a liquid carrier, it can produce thicker coatings than conventional liquid coatings without running or sagging, and powder coating produces minimal appearance differences between horizontally coated surfaces and vertically coated surfaces. Because no carrier fluid evaporates away, the coating process emits few volatile organic compounds (voc). Finally, several powder colors can be applied before curing them all together, allowing color blending and bleed special effects in a single layer.

Most powder coatings have a particle size in the range of 2 to 50 μ (Microns), a softening temperature T_g around 80 °C, a melting temperature around 150 °C, and are cured at around 200 °C. For minimum 10 minutes to 15 minutes (exact temperatures and times may depend on the thickness of the item being coated).^[1] For such powder coatings, film build-ups of greater than 50 μ (Microns) may be required to obtain an acceptably smooth film. The surface texture which is considered desirable or acceptable depends on the end product. Many manufacturers actually prefer to have a certain degree of orange peel since it helps to hide metal defects that have occurred during manufacture, and the resulting coating is less prone to showing fingerprints.

There are very specialized operations where powder coatings of less than 30 micrometres or with a T_g below 40 °C are used in order to produce smooth thin films. One variation of the dry powder coating process, the Powder Slurry process, combines the advantages of powder coatings and liquid coatings by dispersing very fine powders of 1–5 micrometre particle size into water, which then allows very smooth, low film thickness coatings to be produced.

For garage-scale jobs, small "rattle can" spray paint is less expensive and complex than powder coating. At the professional scale, the capital expense and time required for a powder coat gun, booth and oven are similar to a spray gun system. Powder coatings have a major advantage in that the overspray can be recycled. However, if multiple colors are being sprayed in a single spray booth, this may limit the ability to recycle the overspray

1.2 ADVANTAGES OF POWDER COATING

1. Powder coatings contain no solvents and release little or no amount of Volatile Organic Compounds into the atmosphere. Thus, there is no longer a need for finishers to buy costly pollution control equipment. Companies can comply more easily and economically with the regulations of the
2. Powder coatings can produce much thicker coatings than conventional liquid coatings without running or sagging.

3. Powder coated items generally have fewer appearance differences between horizontally coated surfaces and vertically coated surfaces than liquid coated items.
4. The wide range of speciality effects are easily accomplished using powder coatings that would be impossible to achieve with other coating processes.
5. Curing time is significantly faster with powder coating as compared to liquid coating.

2. THE POWDER COATING PROCESS

The powder coating process having three basic steps:

1. Preparation or the pre-treatment
2. The powder application
3. Curing

2.1 PRETREATMENT PROCESS

Pretreatment is a process that your manufacturer goes through to remove all grease, oils and dirt from the AL & MS surface. They need to do this before painting or powder coating to strengthen adhesion.

This process has multiple steps, and each one of them is important.

2.2 PROCESS FOR MS

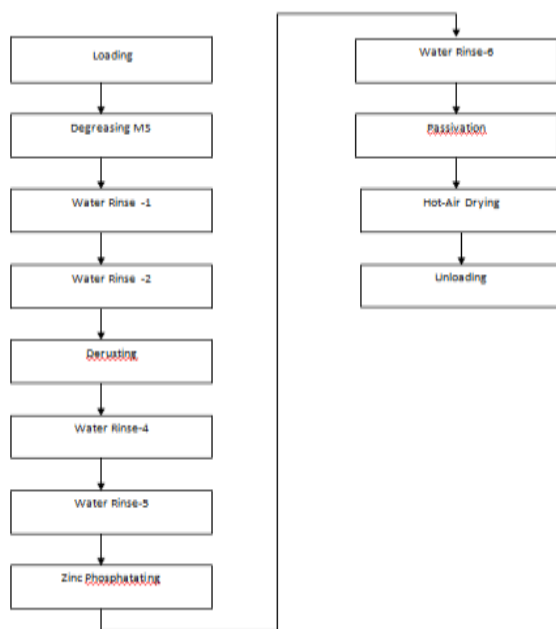

Fig 1. Process for MS

2.3. PROCESS FOR AL

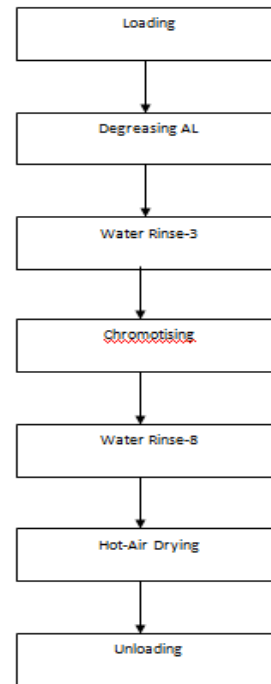
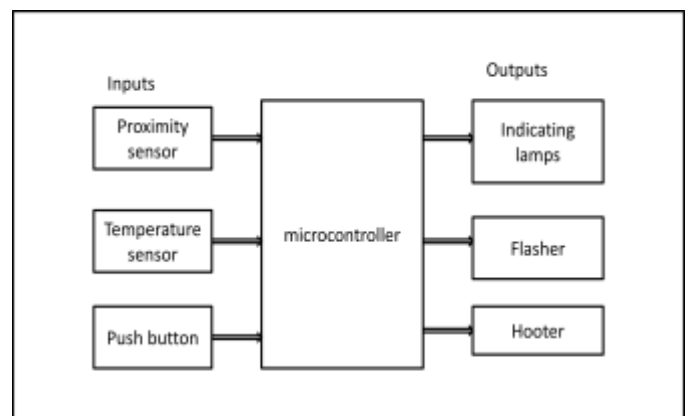

Fig 2. Process for AL

3. BLOCK DIAGRAM



2019-07-20

Fig 3 block diagram of pretreatment processing module

3.1 WORKING

The proximity sensor is kept besides the tank such that it can sense the metal in basket as it is a metal sensor. When sensor senses the metal then timer will start as per required time for the process. If metal is dislocate from the

tank then timer will stop and gives alarm through hooter and flasher. After relocate the metal timer will resume from this time and continues the process which is required.

After sensing the metal if temperature of chemicals in the tank is not as required then timer will not start and alarm will be start till we will set the temperature.



Fig. 3 ESP8266 NODEMCU



Fig 4 PT100 Temperature sensor



Fig 5 MAX31865 RTD amplifier

4. FRONTEND

4.1 TANK MONITORING

Table -1: Sample Table

Sr_no	time in	timeout	basket	date
42	11:34:56	11:48:48	1	2019-05-29
43	11:51:20	12:41:27	1	2019-05-29
44	12:44:41	13:06:25	1	2019-05-29
45	13:06:30	13:20:00	1	2019-05-29
46	13:34:13	13:56:46	1	2019-05-29
47	15:31:56	15:50:04	1	2019-05-29
48	15:50:31	16:02:57	1	2019-05-29
49	18:06:06	18:29:17	1	2019-05-29
50	18:34:00	18:52:11	1	2019-05-29
51	18:57:54	19:35:12	1	2019-05-29

A frontend shows when the basket has been in the tank and when it has been taken out i.e in time and out time of the basket. The data of all tanks are sent by wifi using Arduino ide. Hence we get all data on our frontend webpage.

5. GRAPHICAL PRESENTATION

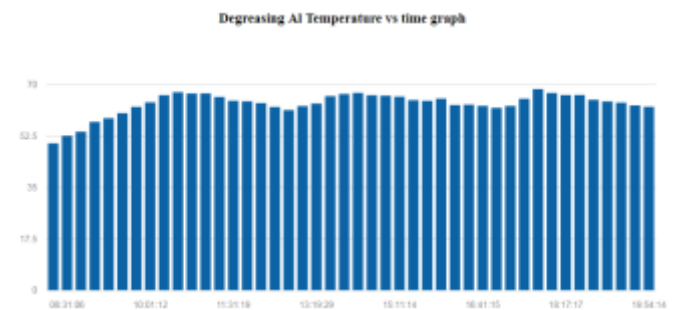

Chart -1: temperature VS time

Graphical representation makes a complicated thing to view in an easier way so that we can derive conclusions and results from it. We have therefore created a graphical representation using morris.js platform to plot the temperature VS time graph for degreasing AL and MS.

6. CONCLUSION

From all the above discussion we can conclude that the pretreatment process is very important before powder coating process. We can improve the quality of metal by this module and save the time also. We can monitor the

multiple parameters like time required for metal is properly given or not, temperature. We can monitor that whether metal has gone through the all stages of pretreatment or not. Graphical presentation is giving us the proper scenario of all the process.

ACKNOWLEDGEMENT

This project consumed huge amount of work, research and dedication. Still, implementation would not have been possible if we did not have a support of many individuals and organizations. Therefore we would like to extend our sincere gratitude to all of them.

First of all we are thankful to [S.S. Controls – Mr. Suresh Todkar] for their financial and logistical support and for providing necessary guidance concerning projects implementation.

We are also grateful to [NIELIT, Aurangabad] for provision of expertise, and technical support in the implementation. Without their superior knowledge and experience, the Project would like in quality of outcomes, and thus their support has been essential. We would like to thank our executive director Dr. Sanjeev Kumar Gupta and my guide Mr. Lakshman K.

Nevertheless, we express our gratitude toward our families and colleagues for their kind co-operation and encouragement which help us in completion of this project.

REFERENCES

- [1] <https://circuitdigest.com/microcontrollerprojects/arduino-analog-speedometer-using-irsensor>https://www.rit.edu/affiliate/nysp2i/sites/rit.edu.affiliate.nysp2i/files/pdfs/powder_coating_process_final.pdf
- [2] <http://www.beltconveyors.in/blog/belt-conveyorsmajor-uses-applications/>
- [3] Phoenix Conveyor Belt Systems. (2004). Design Fundamentals. Hamburg pp. 1-16.
- [4] Zhongyan Du, Shaoguo Wen*, Jihu Wang, Changle Yin, Rulmeca. Technical information. Project and Design Criteria for Belt conveyors. pp. 1-50.
- [5] Zhongyan Du, Shaoguo Wen*, Jihu Wang, Changle Yin, Dayang Yu, Jian Luo, "The Review of Powder Coatings," published, 2016.