

# CAN Based Data Acquisition and Data Logging System for Vehicular Communication

Lavita Floria Vas<sup>1</sup>, Dr. Vasundara Patel K S<sup>2</sup>

<sup>1</sup>MTech. in VLSI Design and Embedded Systems, B.M.S.C.E., Bangalore.

<sup>2</sup>Professor, Department of ECE, B.M.S.C.E., Bangalore, Karnataka, India.

\*\*\*

**Abstract** – This paper shows the design of an advanced CAN bus based Data Acquisition system, focused on improving the vehicle to vehicle or vehicle to base station transport means by acquiring data from various sensors and taking the correct measures after examining the data in order to have a smooth and safe journey. An application based built in DAQ system, initially built on 32-bit RISC ARM platform that included embedded software, user interface technologies, CAN communication, data storage and technology management. This design also comprises of an RTOS and LPC2129 unit present in its embedded design thus resulting in a sophisticated CAN bus-controlled system. The system created accepts data sent from various digital and analog sensors. A sampling frequency of 500 Hz is set on 32 AD channels. The final data obtained is further examined and sent to a cloud through a Wi-Fi gateway for peer-to-peer and also other devices-to-peer communication.

**Key Words:** Data Acquisition, CAN Bus, LPC2129, sensor, Wi-Fi.

## 1. INTRODUCTION

In today's era the universe functions depending on aspects that rely on accumulating data and obtaining subsequent analysis. A superior field where acquired data is used to build up more and more sophisticated systems is automotive area. In a highly competitive surrounding today, the data obtained helps in engine monitoring, tuning of vehicles and providing a secure and safe driving environment. The assembly of vehicles has become very detailed yet complex which increases the standard of automation. In the present system CAN technology is used to extract data related to the vehicle and any error information pertaining to it. With rise in complexities in automotive systems, its maintenance and error examination has become highly challenging [1].

Introducing a DAQ based system which includes RTOS and LPC2129 results in a sophisticated control system based on CAN network. The Controlled Area Network bus that is utilized for obtaining data is well recognized for its high reliability, for tolerance and low cost. CAN based embedded system is user friendly, customizable and further can be expanded by using other devices [2].

## 1.1 Data Acquisition concept

The procedure used for evaluating signals which determine physical conditions of real time surroundings and later transforming the obtained samples to digital data to be evaluated by a computer system is called data acquisition (DAQ). DAQ is used to modify analog waveforms into digital values which are later on processed and evaluated. The DAQ is divided into three units namely:

- Sensors which convert the acquired physical data to electrical signals.
- Signal conditioning circuits that modify signals from sensors to numeric data.
- ADCs are introduced to modify sensor signals to digital outputs.

DAQ systems are usually controlled by software programs designed in basic C, C++, Assembly level language, embedded C etc.

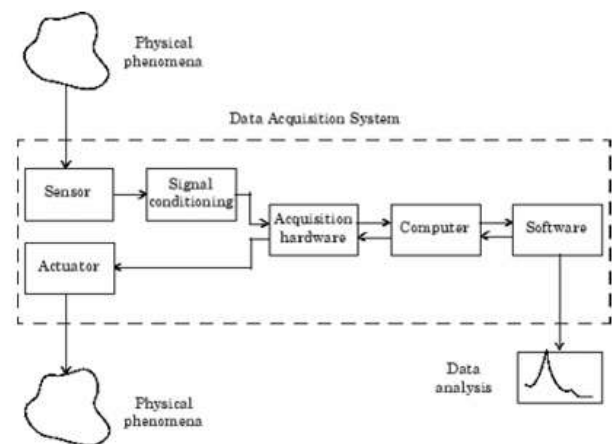

Fig -1: Sample flow of DAQ

## 2. System Hardware details

In this network the transmitter consists of LPC2129 and CAN controller, CAN based transceiver and ADC convertor. The CAN packets which are transferred by the external environment are accepted by a single receiver. The receiver node consists of two LPC2129 ARM controllers and a single CAN controller. Data is logged over 32 10 bit analog to digital convertor channels. CAN packets are transferred via

different units like ECM etc. and further more can be stored in an expandable system or uploaded to cloud through a Wi-Fi gateway. The data from the cloud can be used for peer to peer or peer to device communication [3][5].

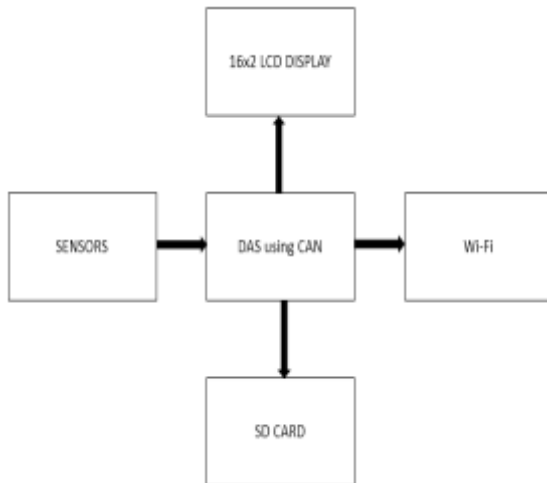

Fig -2: Basic Network Outline

2.1 LPC2129

LPC2129 is constructed over a 16 bit or 32 bit ARM 7 processor, this helps in obtaining real-time emulation and also embedded system support and can include a high speed flash memory (upto 256 kb). The LPC21xx series are highly applicable for automotive, industrial, medical systems and so on.

LPC2129 comprises of a compact 64 pin configuration along with a 32 -bit timer, 10 bit ADC consisting of four channels with a conversion time of 2.44 μs. It consists of serial interfaces like UART, SPI and fast I2C. It also comprises of in application programming InSystem programming.

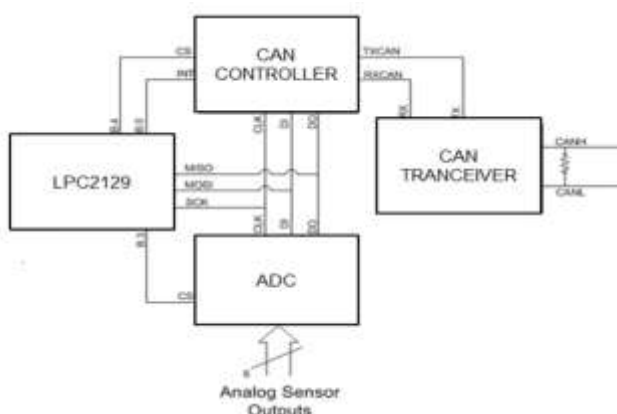

Fig -3(a): LPC2129 AND CAN basic module

In LPC2129 we can find two UART modules, they are UART0 and UART1. In UART0 communication 2 port pins are utilized that is P0.0 and P0.1 for transmission and reception

purpose respectively. These have RXD0/1 as receivers and TXD0/1 as transmitters. The UART pins are configured as per the user's needs and the LPC2129 pins will be further multiplexed for various functionalities. Initialization of serial communication can be done using six registers of eight bit capacity namely LCR(Line-control-register ),LSR(Line-Status-Register),DLLSB(Device- Latch-Least-Significant-Bit), DLMSB(Device- Latch-Most-Significant-Bit),RBR(Receiver-Buffer-Register),THR(Tranmitter-Holding-Resistor).LPC2129 consist of a 16 byte in built FIFO, which are used for transmission and reception. For apt functioning of UART the GPIO pins must be configured using PSR (Pin-Select-Register).

2.2 Controlled Area Network

Data acquisition network employs CAN and LPC2129 core controller. This CAN is a standard bus built for microcontroller communication and devices related to a host computer. CAN protocol was primarily developed for automobile sector to tackle complex wiring systems, this is a message based protocol.

In the year 1983 Bosch initiated the development of CAN, it was widely introduced to the market in 1986 at a conference SAE (Society of Automotive Engineers) held in Michigan State. After this firms like Intel, Philips introduced CAN controller chips in 1987. In 1988 BMW 8 series included wiring system based on CAN for the first time later on Bosch released CAN 2.0 in 1991 [4].

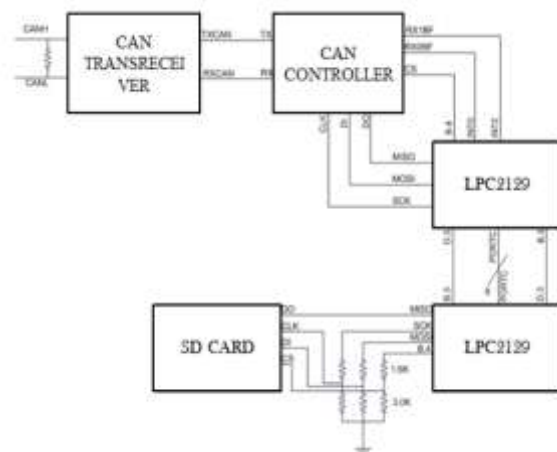

Fig -3(b): LPC2129 AND CAN along with external SD Card basic module

CAN specifications are divided into two parts, Part A includes a 11 bit std. format identifier and is known as CAN 2.0 A, whereas Part B includes a 29 bit extended format identifier known as CAN 2.0 B. The CAN protocols are continuously developing and the latest release was by Bosch in 2012 called CAN FD (CAN flexible data). This introduces a unique frame format which helps in having a flexible data length and rapid bit rate after determining the arbitration.

CAN FD can easily combine and co exist with the existing CAN.

### 2.2 Liquid Crystal Display

Two states of matter that is solid and liquid combined together to form an LCD screen display. It is developed with grids of passive display or active matrix. LCD screen utilizes the principle of blocking light to produce display rather than emitting light thus it needs a back light source. E blocks are used to design a 16x2 LCD where 16 stands for characters and 2 stands for lines. The display is in serial format and it utilizes a 5 V power supply. It has a command register along with a data register, where the command register takes the instruction and stores it. This is later passed on the LCD to execute the task; therefore, it is called LCD command. Data register stores data to be displayed on the LCD. The stored data is in ASCII format of a given character. Initially the system display must be clear.

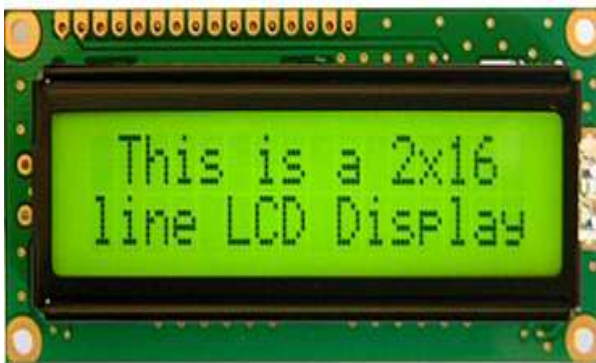

Fig -4: 16x2 LCD screen

### 3 Sensors

The device which monitors events, determines changes in its surrounds and sends the data related to such changes so as to alter connected electronics is called sensor. These normally are built detect to respond to electrical or optical signals. Sensor normally transforms physical aspects mainly humidity, pressure, temperature, moisture and so on to electrically measured signals. Both analog and digital sensors are available.

#### 3.1 Infrared Sensor

IR sensors are designed to absorb infrared light therefore they can't detect visible light. IR microchips are utilized in the place of detectors which comprise of a photocell. This photocell is tuned to determine IR light. A demodulator is inserted inside an IR detector which helps in selecting IR signals at 38 KHz. This sensor can sense IR signal of 38 KHz frequency. It uses a 5V power supply.

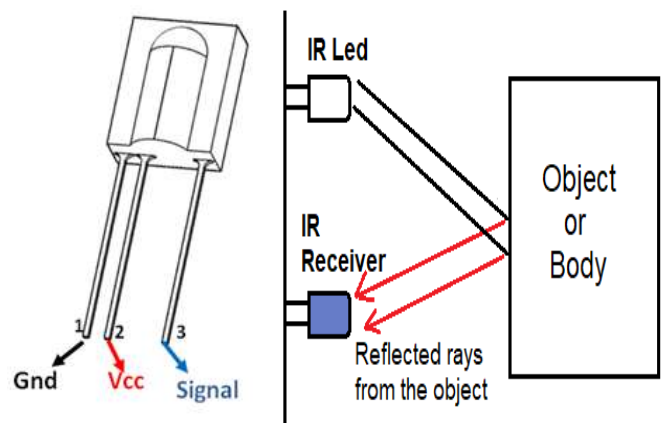

Fig -5: 16x2 LCD screen

#### 3.2 Temperature Sensor

IC sensors having high precision and output voltage linearly proportional to temperature are known as LM35 temperature sensors. Such sensors are simpler in comparison with Kelvin scale calibrated sensors because it doesn't require a constant  $v/g$  value to be subtracted from the output  $v/g$ . LM35 sensors can provide accurate readings for temperatures varying from  $-55^{\circ}\text{C}$  to  $+150^{\circ}\text{C}$ .

#### 3.3 Moisture Sensor

Soil moisture sensor has many characteristics its sensitivity is adjustable and threshold levels can be altered as per the user needs. For installation purpose the sensor consists of fixed holes. The sensor has multiple output modes which give out digital output, analog outputs can be achieved with higher accuracy and the output is normally serial. A +5V regulated DC is the operating voltage. This sensor predicts the dampness of soil. The probe consists of more than two moisture sensors. The moisture content in soil can be determined by the impact caused on the dielectric constant. In desert areas or sandy places dielectric constant is directly proportional to the moisture content present in it because here moisture is free from water form.

#### 3.4 Universal Gas Sensor

Leakage of gas can be detected at home or industrial areas using gas sensors. Mostly smoke, LPG, carbon monoxide, methane, alcohol and other flammable gases. Here MQ2 sensor is used as these provide high sensitivity and have a good response time which means the output obtains is quick and further actions can be taken. The fine tuning of sensitivity can be done using a potentiometer and this sensor analog as well as digital output and uses a 5V power supply.

### 3.5 Rain Sensor

Rain sensor as the name suggests is used to sense rain. Rain sensor consists of a rain board that is kept at distance from the control board which senses the rain droplets to avoid any damage to main circuitry due to water. A potentiometer is used to adjust the sensitivity and it also consists of an LED light indicator. The sensor is attached to a 5V power supply. When water is detected on the rain board the LED will glow and the output is high. This sensor has an anti-oxidant along with anti-conductive property for long shelf life.

### 3.6 Wi-Fi

Wireless Fidelity or WiFi is used for network communication, this uses radio frequency to provide wireless internet, and this is the most commonly used wireless technology today. It works on standards of IEEE802.11. PSCP or also called Espressif Systems Smart Connectivity Platform is a package of high and fast wireless SOC's. These are utilized in mobile platforms to provide access to embedded WiFi within various systems and display great functionality. This combination provides a self sufficient and sophisticated WiFi network solution and permits it to host an application or offload all WiFi functionalities from various processor applications. ESP8266 was mainly introduced for wearable electronics, various IoT applications and mobile communication with an aim to achieve results by consuming less power.

### 3.7 SD Card

Secure digital card allows users to get access to files on totally 6 different flash card form factor without having a need for awareness of the details of file access/ flash card interface. Simple interface of C can be applied to access the SD card, and this is provided by user module. Characteristics of SD card helps for accessing multiple files randomly and also read and write operations can be performed on its multiple files. The SD Card interface is attained by using a SD card user module and its communication with SD card is obtained by the use of digital blocs in SPI mode. There are 6 signals in which 2 can be optional and rest are like SPI interface. To label these signals present between SD card and PSoC the reference is taken from SD card. To use less RAM and flash space the SD Card interface is written carefully.

### 4 Design Approach

The data is collected from the external sensors in the form of CAN packets and transferred via a CAN bus. These transmitters generally consists of ARM controller (LPC2129), and a CAN-controller along with CAN-transceiver, plus an ADC. This data is analyzed after acquisition and the resulting required data is then transferred to a cloud (via Wi-Fi) or stored in SDCard.

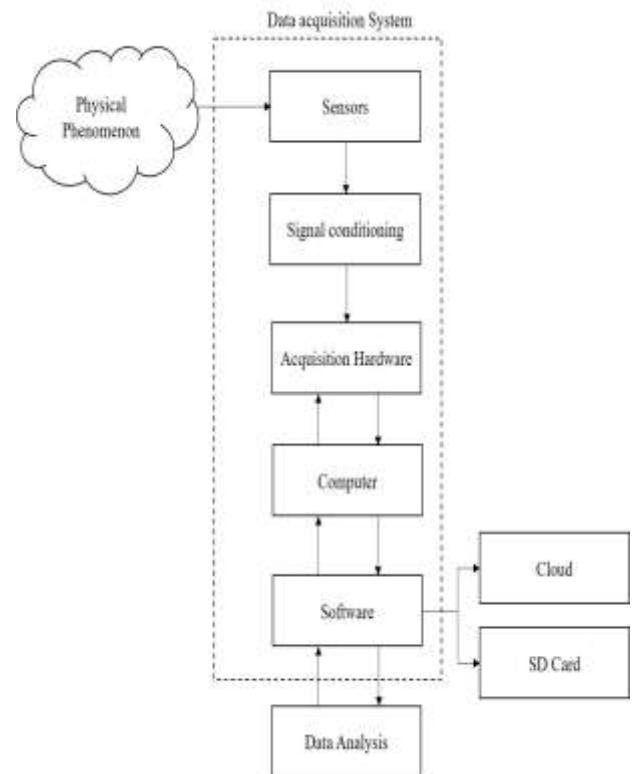

**Fig -4:** Design Flow

### 5 Results

The results obtained by various sensors data acquisition can be noted down through LCD Display screen.



**Fig -4:** IR sensor without any Object Obstruction



**Fig -5:** IR sensor output with Object Obstruction



Fig -6: Room Temperature surrounding the device depicted by temperature sensor.



Fig -7: Moisture Undetected when the sensor is not in contact with any damp soil surface.



Fig 8-: Moisture detected when the sensor is in contact with any damp soil surface.



Fig 9-: Gas Detected when the sensor senses any gases or fumes.



Fig 10-: Rain Detection results.



Fig 11-: Results obtained via Wi-Fi sent by the IR sensor.

Ubidots cloud helps applications to convert the real world data to detailed values so as to take necessary actions.

### 5. Conclusion

Designing this particular system is based on CAN bus architecture with the help of embedded C and other external sensors. Such software design approach is highly flexible and sophisticated. This system provides the user with high stability, reliability and high quality aspects related to automation and the overall system is very cost effective. The center focus of this paper is to modernize automotive and various other industries which depend on data acquisition obtained in real time. Today IoT applications are being efficiently applied in peer to peer transport communication. To be connected to other means of transports on road drastically improves the driving quality. The combination of smart automotive systems and predictive analysis is a best substitute for driver emergencies for now such technologies are still in their developing stages and few legislation also been considered for promising intelligent driving assistance technologies. The rise in popularity of 4G networks and emerging 5G networks builds a suitable scenario for introducing connected vehicle system. Such systems can carry information to next dimensions such as transferring data in real time to passengers.

### REFERENCES

- [1] M.Santhosh Kumar, Balamurugan, "Self Propelled Safety System Using Can Protocol", Journal of EEE.
- [2] A. A. Salunkhe, Pravin Kamble, Rohit Jadhav, "Design & implementation of CANbus protocol for monitoring vehicle parameters", IEEE- (RTEICT), 2016.
- [3] Vinoth Khanna, Kirthika, Revathi, "Automobile Data-Acquisition and Processing-System Based on Dual-CPU Architecture", IJSETR 2013.
- [4] Bosch's "CAN-Specification, 2.0" guide.
- [5] "Bosch Controller-Area-Network Version 2.0", Freescale Semiconductor, Inc.
- [6] NXP's "LPC2119/LPC2129, V.03" guide.