

Speed Control of Induction Motors using Proposed Closed Loop v/f Control Scheme

G N Madhu¹, PatelaNaik L²

¹Associate Professor, Dept. of Electrical and Electronics Engineering, UBDT, Davangere-577004, Karnataka, India

²PG Student, Dept. of Electrical and Electronics Engineering, UBDT, Davangere-577004, Karnataka, India

Abstract – The main aim of this project is the speed control of three-phase induction motor. There are many methods for this process some of them are: (1) Stator voltage control method. (2) Rotor resistance control method. (3) By changing the number of poles. Etc. But the most preferred and used method for the speed control of induction motor is the v/f control method. Which leads to the best performance and high efficiency to the motor. In the case of shortage of electricity the unwanted energy has to be saved.

Volts/hertz (V/Hz) control of three-phase induction motor is popular control method, although of low dynamic performance, because of its simplicity and low cost. Closed loop system, including an appropriate controller, is used to obtain a good speed control. Proportional-integral (PI) controller is commonly used, and good design of this controller requires an accurate mathematical model of the system. Another controller is the fuzzy logic controller, where linguistic rule base, based on human expertise, is used. Therefore, obtaining a good controller may violate the simplicity of V/Hz control system. In this project, a simple V/Hz control system is proposed.

Key Words: Induction Motor, Closed Loop, PI Controller, Pulse Generator, Speed Regulator, Flux Regulator.

1. INTRODUCTION

Speed control of three phase induction motor by using of volts/hertz (v/f) control method is commonly used in the industries because of it is simple and of its cost is low, and it gives an accurate value of steady state speed of the motor. Typical closed loop system method is explained in this model. The difference between the reference speed and the motor speed is used by the proportional integral (PI) controller to trace the speed of the slip, and give the accurate steady state speed.

However design of the PI controller needs an accurate mathematical model of the system, and it is difficult to obtain accurate parameters of the model in case of complex nonlinear and time varying dynamic interactions of the induction motors. In many cases fuzzy logic controller is alternative to proportional integral controller. Nonlinear and time varying dynamic interactions of the induction motors. In many cases fuzzy logic controller is alternative to proportional integral controller.

1.1 SPEED CONTROL OF INDUCTION MOTOR

An induction motor is an asynchronous AC (Alternating current) motor. The least expensive and most widely used induction motor is the squirrel cage induction motor. The interest in sensor less drives of induction motor has grown significantly over the past few years due to some of their advantages, such as mechanical robustness, simple construction and less maintenance

Induction motors are far more widespread than any other electric machine in industry. According to several surveys, these machines demand around 40%–50% of the total energy generated in a developed country. Hence, sudden failures in these machines can be catastrophic for the processes in which they are involved, leading to significant economic implications.

1.2 PI CONTROLLER

Induction machines are most frequently used in industries due to their robustness, low cost and reliability and high efficiency. Squirrel cage rotor, is the most widely used source of mechanical power fed from AC power system due to its low sensitivity to disturbance.

During starting, Induction motor draw large current which produces voltage dips oscillatory torques and also able to generate harmonics in the power system.

When accuracy in speed response is a concern, closed loop speed control is implemented with the constant v/f control. A PI controller is employed to regulate the slip speed of the motor to keep the motor speed at its set value.

1.2 CLOSED LOOP V/F SPEED CONTROL METHOD BY USING PI CONTROLLER

Speed control could have been done with open loop also. Open loop control is the simplest type of control without any feedback loop, and without much complexity. But there lies many advantages of closed loop control over open loop control, for which closed loop control is preferred over open loop control.

- The controlled speed accurately follows the desired value.
- Effect of external disturbances on controlled speed is very less

- Also use of feedback in the control greatly improves the speed of its response compared to that of open loop case

2. METHODOLOGY

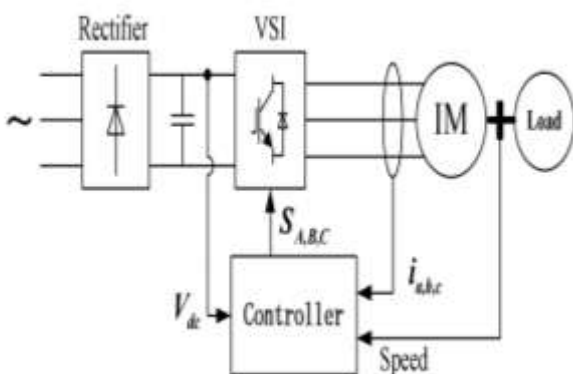
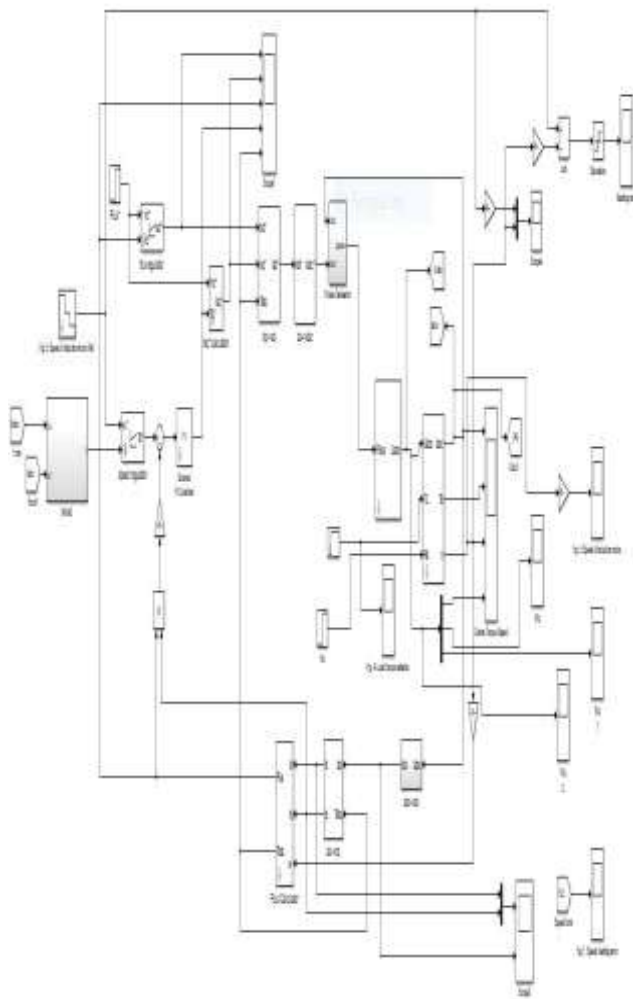

FIG 1 Basic Diagram

First a closed loop v/f control with PI controller is simulated where PI controller and VSI will be connected to the induction motor. Then a feedback of rotor speed will be taken from the induction motor and compared with the reference speed and then the error will be fed to the controller and output of the PI controller will fed to the VSI. In that way performance of induction motor with this controller is studied.

Whenever the induction machine was loaded the speed of the machine fell, but constant speed drive demands a constant speed throughout its application irrespective of loading. So to provide that constant speed PI controller in a closed v/f loop is used where it generates the required speed command to provide the desired constant speed. From the speed v/s time graph it can be seen and concluded that speed remains constant irrespective of motor loading, and from current v/s time it can be seen that current increases

2.1 SIMULINK MODEL

Fig 2 Simulink Model of The Speed Control of Induction Motor by using v/f Method Closed Loop System

Scalar Control In this method the magnitude of the control variable is taken under variation irrespective of the coupling effect in machine. Scalar control is easy to implement, hence widely used in industries. But the performance of scalar controlled drives become inferior. To improve the performance of the scalar control method an encoder or speed tachometer is required to feed back the rotor angle or rotor speed signal and compensate the slip frequency. However, it is expensive and destroys the mechanical robustness of the induction motor.

3. PARAMETERS

Flux Regulator

Proportional gain=1, Proportional integral=0.01

Speed Regulator

Proportional gain=1, Proportional integral=0.1, sampling time=1e-4

PI Controller

Proportional gain=1, Proportional integral=0.01, output limit-(2000-2000), Sampling time=1e-4, output initial value=2.

Flux Calculator

Motor Inductance (Lm)=0.510H, Pairs of poles=2, Rotor Inductance(Lr)=0.533H, Rotor Resistance(Rr)=2.5Ω.

Inverter

DC Voltage=600V

Asynchronous Motor

Stator Resistance(R_s)=4.1 Ω , Stator Inductance(L_s)=0.545H,
Rotor Resistance(R_r)=2.5 Ω , Rotor Inductance(L_r)=0.533H,
Mutual Inductance(L_m)=0.510H,
Pairs of Poles=2, Inertia=0.02Kg.m².

4. RESULTS AND DISCUSSIONS

The design, development and performance of speed control of induction motor using proposed closed loop v/f control method.

Simulink is a block diagram environment for multi domain simulation and Model-Based Design. It supports system-level design, simulation, automatic code generation, and continuous test and verification of embedded systems. Simulink provides a graphical editor, customizable block libraries, and solvers for modelling and simulating dynamic systems. It is integrated with MATLAB, enabling you to incorporate MATLAB algorithms into models and export simulation results to MATLAB for further analysis.

Model analysis tools include linearization and trimming tools, which you can access from the MATLAB command line, plus the many tools in MATLAB and its application tool boxes. Because MATLAB and Simulink are integrated, you can simulate, analyze, and revise your models in either environment at any point.

After you build the Simulink block diagram, you can simulate the model and analyse the results. Simulink allows you to interactively define system inputs, simulate the model, and observe changes in behaviour. This allows you to quickly evaluate your model.

OUTPUT WAVEFORMS

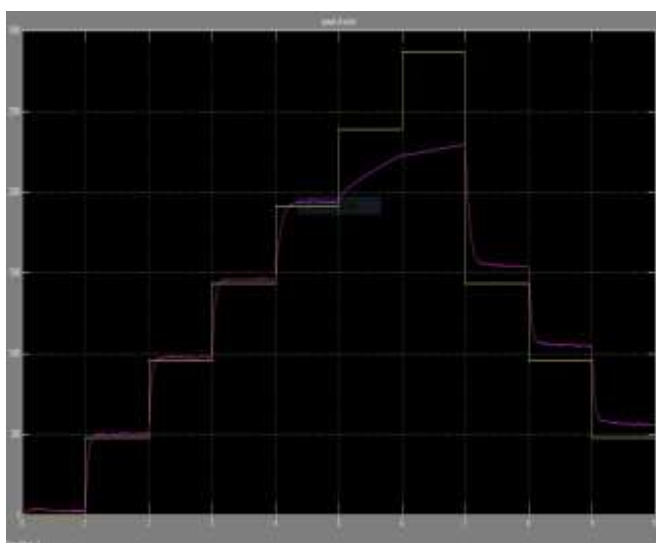

Fig 3 Speed of Motor

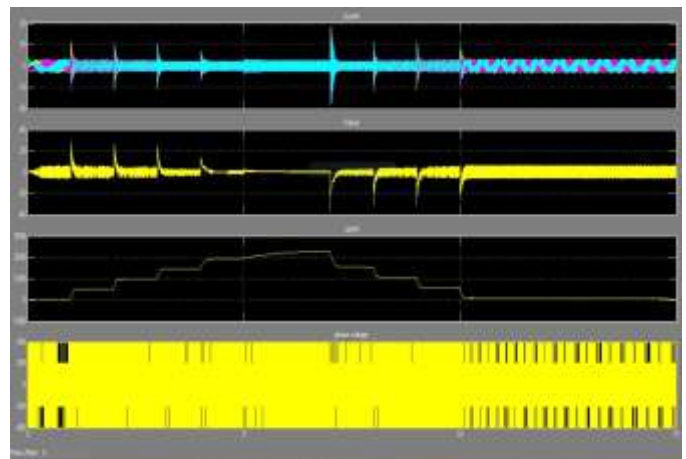

Fig 4 Speed of Motor, Current, Torque and Voltages

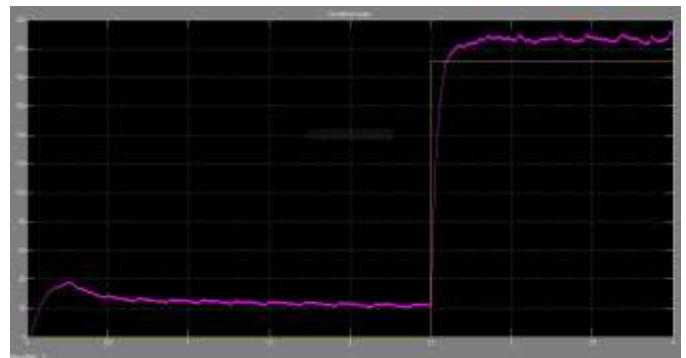

Fig 5 Developed Torque

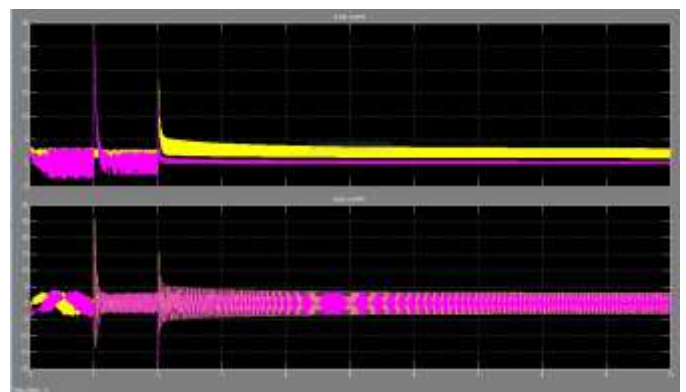

Fig 6 Currents



Fig 7 speed of Induction Motor

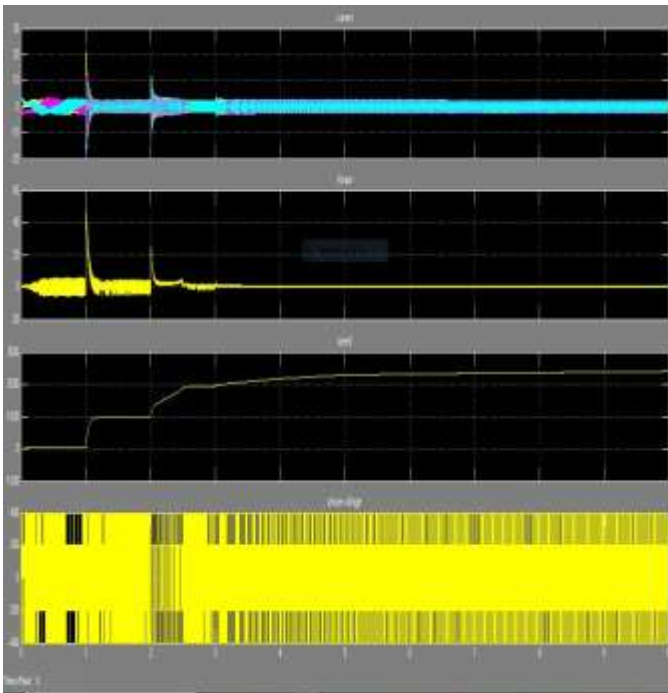

Fig 7 Speed of Motor, Current, Torque and Voltages

Above Figure shows results of the system load in case of time changes with gradual changes of the Speed of Motor, current, torque and voltages.

5. CONCLUSIONS

A simple volts/hertz control method of the three phase induction motor is proposed. The simplicity of the proposed closed control loop system, and this scheme is depends on the nearly linear relationship between the load torque and slip speed of induction motor at constant stator flux linkages.

When increasing the load slightly decreasing the speed of motor, then here we will get the output of direct and quadrature axis currents. Here get developed of current torque speed and also developed the how speed control of induction motor and tracking the speed of motor.

We preferred to control the speed of an induction motor using PI controller, here we control speed of the motor by controlling v/f ratio of that motor.

REFERENCES

- [1] M Arrofiq, N Saad "PLC-based Fuzzy Logic Controller for Induction-motor Drive with Constant V/Hz Ratio.
- [2] M Suetake "Embedded DSP-Based Compact Fuzzy System and Its Application for Induction-Motor V/f Speed Control".
- [3] H Asgharpour alamadri, Y Alinejad bemori and H Yagahobi "a Fuzzy based Speed Controller for Improvement of Induction Motor's Drive performance.

- [4] D Asija "Speed Control of Induction Motor using fuzzy-PI controller" in 2010 2nd International Conference on Mechanical and Electronics Engineering, Kyoto, Japan.
- [5] Chung-Yuen Won, Duek Heon Kim "An Induction Motor Servo System with Improved Sliding Mode Control" year of 1992.
- [6] N.B. Muthuselvan, S. S. Dash, and P. Somasundaram, "A high performance induction motor drive system using fuzzy logic Controller," in Proc. 2006 IEEE Region.
- [7] J. Martínez García, J.A. Domínguez, "Comparison between Fuzzy logic and PI controls in a Speed scalar control of an induction machine," CIRCE - ge3 - Departamento de Ingeniería Eléctrica C.P.S., Universidad de Zaragoza, Conf. Paper.
- [8] "Simulation and comparative study analysis of speed control of induction motor using fuzzy logic, PI, PID controller" by teena patil and P.P.Mahajan in IJIEEE journal in aug 2016.
- [9] A.Gupta, "Simulation of Variable Speed Squirrel Cage Induction Motor Constant Volts/Hertz Operation", IEEE International on Electric Machines and Drives Conference Record, pp. TB3/8.1 -TB3/8.3, 1997.