

GSM Based Voltage Monitoring & Power Factor Correction

Priyanka K. Sonone¹, Vaishali D. Kamble², Shital V. Uke³, N. V. Yawale⁴

^{1,2,3}Student, Dept. of Electrical Engineering, DES'S COET, Dhamangaon Rly

⁴Professor, Dept. of Electrical Engineering, DES'S COET, Dhamangaon Rly

Abstract – Now a days, a controller that improves the power factor (PF) is automatically designed and implemented to correct the value of the power factor once they falls below a certain one. Due to the modern civilization the growth of industry has been increased as thus the usage of energy has been raised. So , every industry needs to implement power factor correction to limit power wastage and to avoid penalty due to the same. Lower power factor means that higher current is flowing through it, Higher current results in greater voltage drop. The aim is to build a simple compact and energy efficient system for automatic power factor monitoring and control. It incorporates PIC 16F877 microcontroller kit along with zero crossing detector circuit and relay driver circuit. The voltage and current parameters are detected and controlled by using GSM.

Key Words: Power Factor Correction, GSM Module, PIC Microcontroller.

1. INTRODUCTION

Power factor for the sake of simple definition is the ratio between the real power and the apparent power drawn by an electrical load and this ratio can vary between 0 and 1. The ratio which we have defined above is not a mere theoretical quantity which can be confined to books. It is a quantity that has got wide range of significance in real world day to day phenomena. It is a measure of how effectively the current is being converted into useful work output and more particularly is a good indicator of the effect of the load current on the efficiency of the supply system. Real power is the capacity of the circuit for performing work in a particular time. Apparent power is the product of the current and voltage of the circuit. At inductive loads, the useful work is done by the active power while the reactive one returns to the source on current cycle, since it dissipates no energy in the load. This may reduce the consumer side voltage because of the high requirement of the reactive power consequently, the continuous load Power Factor monitoring is very essential. When PF falls below a specified value, the line current increases, making the line loss and voltage drop increase too.

The effect of low power factor is large copper loss and poor voltage regulations. The main reasons of low power factor are most of the AC motors are of induction type which have low lagging power factor and arc lamps ,electric discharge lamps and industrial heating furnaces operate at lower power factors. Poor power factor costs our community in increased electricity charges and unnecessary green house

gasses. While some countries provide incentives for customers to maintain requires power factor, some impose penalties for power factor dropping beyond the limit. Thus, power factor control is the most important part of efficient power management.

A new method which improves the power factor automatically of varying lagging loads to unity, using one single large shunt capacitor instead of using a bank of switching capacitors. Basically, this control scheme is a static power factor correction method by continuous voltage or current control of a capacitor. In this work the voltage across the capacitor is being changed by a bi-directional switch to control the magnitude of compensating capacitor current and thereby attaining unity power factor.

This system incorporates high-speed insulated gate bipolar transistor switching technology. The gate signal of the switching devices is generated by using a compact and commercially available IC chip SG1524B. The scheme is simple in this sense that it uses only one static bi-directional switch controlled by an electronic control circuit that uses only analog ICs and some discrete digital components. T. W. Kim et al. suggested a high-performance line conditioner with excellent efficiency and power factor. In this paper they proposed a fast output voltage controller by utilizing a fast input voltage detection method and a feed forward controller with current-limiting capability for various impulsive loads. This paper proposes a technique that is characterized by successful impulsive loading and quick recovery of the output voltage. They proposed a high-efficient line conditioner with excellent performance. The line conditioner comprises of a three-leg rectifier-inverter, which functioned as a boost converter and a buck converter.

2. RELATED WORK

A. GSM technology

GSM stands for Global System for Mobile communications. Developed in 1990, it has become the most popular standard for mobile phones in the world. The implementation environment determines the coverage area of each cell. The boundaries of cells can overlap between adjacent cells (large cells can be converted into smaller cells). The technology uses a blend of frequency division multiplexing (FDM) and time division multiplexing (TDM). Different users at different time slot use different frequency, hence when user is ON, uses channel 900MHz for three seconds, then hop to channel 910MHz for the next three seconds and so on. Frequency Hoping is the term giving to

such process. Amongst the various frequency of the GSM, 900MHz is the operational frequency. It has the ability to re-use frequencies in order to increase capacity and at the same time coverage.

B. Short message service (SMS)

Short Message Service is a common economically affordable service used for receiving and sending messages in text. It uses the GSM network to transfer information. This method of transmitting data is quite popular due to convenience and low cost factor. A single text message can consist up to 160 characters. SMS mobile originated is a term used when a message is sent by a mobile, however when a message is received by a mobile it is termed SMS mobile terminated. Remote data communication and monitoring is supported by SMS due to its bi-directional data transfer and its stable performance. Amit sachen et al have discussed the user can read remote electrical parameters by sending a command in form of SMS messages. Based on the setting, real time electrical parameter can be automatically sent in form of SMS periodically.

Rectification of faults during occurrence of any abnormality in power lines and using SMS through GSM network to inform personnel of this action is also made available. Andriy Palamar et al proposed the system, a Cellular phone which as a Subscriber's Identifying Module (SIM) card with a specific number through which communication is made. The medium of communication is wireless that works on the Global System for Mobile communication technology (GSM). Using cooperative relaying strategies these gains are also possible for single-antenna nodes. The scholars considered the necessary parameters to monitor in this research, with the overall objective of improving the reliability of the power system as a whole. With a cloud-based remote management solution, user can have immediate access to generator parameters via a regular web browser. Temperature sensors is used to sense the temperature of the room and a message is sent to the master mobile whenever the temperature rises beyond the threshold parameter using the GSM modem.

C. Operation of the GSM

GSM Modems are controlled by the microcontroller using the AT commands. However the GSM modem supports a fixed and extended set of AT commands. Defined in the GSM standards are these extended set of AT commands which enables the following functions; - Send SMS messages. - Reading, writing and searching phone contacts. - Monitor signal strength. - Read, write and delete SMS messages.

D. The Arduino Uno Microcontroller

Arduino Uno is one of the famous microcontrollers that has been developed recently and it uses in many applications since it is cheap and easy to program. The ATmega328 represents the base of its board. It has 6 analog inputs, 14 digital input/output (6 of them can be used as

PWM outputs), a crystal oscillator with frequency of 16 MHz, a USB connection, a power jack, an ICSP header, and a reset button. It includes all things that needed for supporting the microcontroller. Arduino Uno can be connected to a battery, power supply with an AC-DC adapter or through a USB cable by using a computer to get started. In this research, the Arduino is programmed to calculate the phase difference between the current and voltage, and then decide which suitable capacitor must be connected with the load to enhance the PF. The decision is made by the aid of a Fuzzy algorithm, which chooses what a fuzzy group does the phase deference belongs to. The C++ program is utilized here for programing the microcontroller (Arduino Uno), and it is downloaded to the board via USB cable. The board of Arduino Uno that used here in this work is stated.

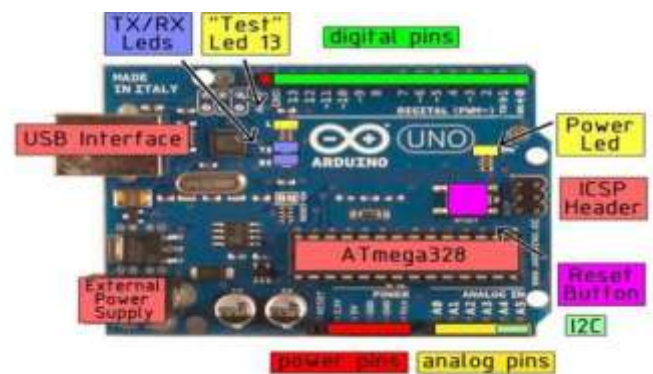

Fig.1. Arduino UNO board

3. METHODOLOGY

The circuit mainly consists of two sections namely power factor calculation and power factor correction. The former section includes the circuitry for the calculation of the power factor of the load connected whereas the later section improves the power factor near to the unity. The loads that we used are exhaust fan, tubular fluorescent lamp, incandescent lamp and glow type zero bulb. The 230 V, 50 Hz is stepped down using voltage transformer.

The power factor is calculated using apparent power and active power. The instantaneous value of current is obtained using a current transformer. This value when passed through filter circuit will give an average value of power which corresponds to apparent power of the circuit. These outputs are fed to the PIC which does the further power factor calculations. PIC 16F877A microcontroller is the heart of this Automatic Power Factor Controller, it finds, displays and controls the power factor. To correct power factor, first we need to find the current power factor. It can be find by taking ratio of active power to apparent power. Then it displays the calculated power factor in the 14*2 LCD Display and switches ON the capacitors if required. When load is connected the power factor is calculated by the PIC microcontroller. If the calculated power factor is less than 0.95 then the relay switches on the capacitor accordingly. The relays are switched using ULN2003 which is basically a driver IC. The current lead in capacitor compensates the

corresponding current lag which is usually present in loads. Hence the phase difference between the current and voltage will be reduced.

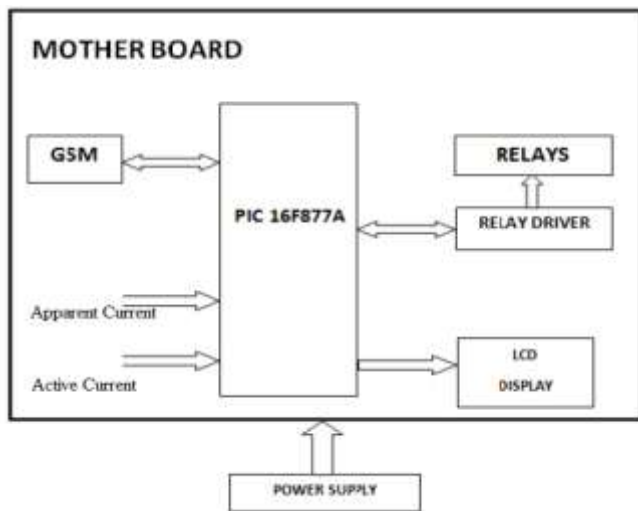

Fig. 2 Block Diagram of the system

4. CONCLUSION

It can be concluded that power factor correction techniques can be applied to the industries, power systems and also households to make them stable so that the system becomes stable and efficiency of the system increases. The use of microcontroller reduces the costs. Due to use of microcontroller multiple parameters can be controlled at a time and the use of extra hardwares such as timer, RAM, ROM and input output ports reduces. The occurrences of faults were displayed and the message was sent through the GSM network over to the utility mobile phone. A bi-directional communication was established as the system was able to receive command from the utility phone to set a short circuit limit.

REFERENCES

- [1] Md. Raju, Ahmed M. J. Alam, Power Factor Improvement by Pulse Width Modulated Switched Single Capacitor, IEEE Proceedings of India International Conference on Power Electronics, Chennai, December 2006, pp. 212 – 215.
- [2] T.W. Kim, J.H. Choi and B.H. Kwon, High-performance line conditioner with output voltage regulation and power factor correction, IEEE Proceedings of Electric Power Applications, ISSN :1350-2352, Vol. 151, No. 1, January 2004, pp. 91-97
- [3] Mr.Anant Kumar Tiwari, Mrs. Durga Sharma, Mr.Vijay Kumar Sharma, Automatic Power Factor Correction Using Capacitive Bank, International Journal of Engineering Research and Applications, ISSN : 2248-9622, Vol. 4, Issue 2 (Version 1), February 2014, pp.393-395.

- [4] Abhinav Sharma, Vishal Nayyar, S. Chatterji, Ritula Thakur, P.K. Lehana, PIC Microcontroller Based SVC for Reactive Power Compensation and Power Factor Correction.
- [5] International Journal of Engineering and Innovative Technology (IJEIT) Volume 3, Issue 4, October 2013 272 Power Factor Correction Using PIC Microcontroller www.arduino.cc
- [6] Design and Implementation of Microcontroller-Based Controlling of Power Factor Using Capacitor Banks with Load Monitoring, Global Journal of Researches in Engineering Electrical and Electronics Engineering, Volume 13, Issue 2, Version 1.0 Year 2013 Type: Double Blind Peer Reviewed International Research Journal Publisher: Global Journals Inc. (USA) Online ISSN: 2249-4596 & Print ISSN: 0975-5861
- [7] Electric power industry reconstructing in India, Present scenario and future prospects, S.N. Singh, senior member, IEEE and S.C. Srivastava.
- [8] Muhammad Bilal Khan, Muhammad Owais Department of Electronic Engineering Faculty of Engineering Sciences & Technology, Hamdard Institute of Engineering & Technology, Hamdard University Karachi, Pakistan 2016
- [9] P.P. Machado Jr , T. P. Abud Fluminense Federal University - UFF Electric and Telecommunications Engineering Master Program – PPGEET Niter rio Rio de Janeiro, Brazil.