

Bridge Crack Detection and Monitoring of using Image Processing

Smruti Deshmukh¹, Dr. P. B. Mane²

¹AISSMS Institute of Information & Technology, Pune, India

²Principal, Member of IEEE, AISSMS Institute of Information & Technology, Pune, Maharashtra, India

Abstract - Monitoring Bridges this day gets very importance as it is the most important part of the roadway, train transportation. The common problem to the bridge safety is today of bridge cracks. The different parameters on which the crack depends are area, length and width. Tiny and the cracks which are not clear that are not detected. Bridges may get collapsed due to many reasons such as flooding, natural calamities, or any concrete problems. Disasters are naturally occurring events which destroys everything including plains surfaces, roads and bridges also. The cracks which occur on bridges can be of various types such as big crack, thin crack, etc. Now when we talk about image processing the image which will be captured should be pre-processed so that we do proper detection of crack the shadow and rough surfaces should not be misinterpreted as crack on the bridge. The study states the maximum allowable crack size is 0.3mm, if the size of crack is more than this the bridge conditions will be not suitable for use. The system which we have builded will help in disaster management and recovery. Bridge crack detection and safety monitoring system can monitor and analyze the condition of the bridge in real time. The environment, and other safety parameters are also monitored. This paper presents a survey of structural health monitoring using WSNs. We are using image processing which have output in our required manner. The image processing gives accurate results of every image captured.

Key Words: Structural health monitoring, WSN, Public safety, Disaster Management, Image Processing.

1. INTRODUCTION

Crack occurs in different surfaces like buildings, roads, pavements, bridges, railway station, tunnel, automobiles, aircrafts, etc. Crack is a separation of concrete surface into two or more parts which are produced due to breaking or fracturing. Active and dormant are two categories of cracks developed in any surface. In active crack the change in direction, width or depth occurs in measured period of time whereas in dormant crack it remains unchanged. If any type of the crack is kept unrectified both active and dormant cracks can provide moisture absorption which led to damages in bridge. There are number of active cracks such as longitudinal crack, miscellaneous crack, transverse crack, reflection crack and crocodile crack. The second type of crack dormant crack is very fine in nature and it can auto heal itself over a period of time. The types cracks based on the structure are thin crack, micro crack, mixed crack, sealed crack, line-like crack, tiny crack, minor crack, medium crack,

complex crack and large crack. In this paper, the improvements in the field of crack detection and research challenges are addressed.

The method to identify the crack from the image using image processing automatically is known as crack detection. There are different image processing techniques such as morphological operation, segmentation, cannel edge detection method, sobel edge detection method, otsu's method, clustering method, gradient method, least square method, particle filter, histogram equalization method, wiener method, maximum entropy method and wavelet transform.

The road comes under main transportation unit of goods and human being and for proper connection of road we require bridges to connect them. Hence bridges play an important role in traffic management. Old bridges cannot face the ups and downs occurring due to natural disasters or natural calamities.

The bridges are nothing but the huge infrastructures which requires large amount of investment and have a long life. Due to this long term serving the bridges faces problems such as loading, erosion, structure-fatigue, material aging etc, the natural aging will appear inevitably. In recent years many accidents occurred due to bridge collapse, this shows that there is urgent need to setup safety monitoring systems. As the bridge is very large in size, we have to evaluate the healthy status of bridge from various parameters such as vibration, deflection, temperature, etc.

Due to earthquake and typhoon flooding incidences of bridge damages have increased. The data which we are going to save will be used for further bridge safety management and disaster rescue operation.

2. EXISTING WORK

The Convolutional Neural Network(CNN) is been used in the crack detection techniques. The structural features are used for detection of crack which are threshold and histogram. CNN are algorithms which are derived from Artificial neural network(ANN). The workload of crack detection is reduced as from direct image crack can be fetched with the help of algorithm. It is also mentioned in future scope that we can collect more images of cracks in bridges and process it with the help of more technologies [1][5]. The MATLAB is used for simulation process and as same Convolutional Neural network is used for detecting cracks of the bridge surfaces.

The internet of things is also used in this paper for identification of cracks occurred in the structures of bridges [2]. A technology named computer vision Technology is being used for detection of cracks. The coordinate mapping and computer vision technology is used for detection of location of crack. A laser ranging system is used for crack measurement. we can take review of crack also by this system [3]. The system gives us the survey of the various patterns of cracks and classification techniques based on the methods proposed in the paper. Here the drawback is false detection can be observed such as shadow can be considered as crack. Different types of crack such as subway tunnel crack, vertical crack, horizontal crack, large crack, longitudinal crack, diagonal crack, mixed crack are studied in this paper [4]. The pre-extraction method and percolation methods are used in this paper. The dark pixels can speed the location of crack in the system the algorithms are used in this paper for pre-extraction and percolation process. The tiny cracks can also be detected by this methods [6]. The artificial intelligence tools, IOT is used for crack detection and disaster management. The victim can also be detected and they can be rescued from the disaster location by the help of this system. Real time processing is done by this systems, data mining algorithm is also used [7]. STRUM classifier is used in this paper. STRUM classifier has 3 parameters such as

- 1) Having a machine learning classifier
- 2) A line segment detector
- 3) Spatially tuned multiple feature computation. The line segments are used in this paper and from this it is detected whether crack exist or not. Crack density maps are observed via global view [8]. It is discussed that whether the image obtained is complex image or normal image. The complex image is that image in which the rocks and other elements on bridge also get captured in the image and the crack get difficult to identify. The need of preprocessing comes here as without preprocessing the crack cannot be modified and removed. The Gabor filter and Wavelet is used for detection of crack in this paper [9]. Video imaging of crack on the bridge is done in this paper the string of video of bridge is captured and the noise is removed from it [10]. The ultrasonic sensor, vibration sensor, load cell sensor, and temperature sensor is being used for monitoring bridge conditions. All the data collected from the sensor is send to the server and the necessary information is being processed and bridge is being monitored [11].

The TCP/IP protocol is being used and Wi-Fi module is being used for communication purpose. The types of users allowed are administrator and user. If the system not work properly the data can be fetch from the cloud server [12]. In this system water level point sensor, weight sensor is being used for monitoring purpose. Arduino microcontroller is being used for controlling all parameter. A servlet is being used as a web server in this paper [13] [16]. Bridge tracking gadget,

wireless sensor network, IR sensor, water sensor, alert generation system is being used in this paper. Here mobile is used for communicating purpose. Arduino microcontroller is used handling all hardware and software part of the system [14]. The ZigBee technology is being used by the author and wireless sensor network is been used. The system consists of monitoring units, photovoltaic units, Wireless Communication System. Follow up researches are done with the help of data stored in the server [15]. The raspberry pi technology is used for generation for programming. The system designed consists of wireless transmission of data, location of sensor network, management center, and intermediate module. Sensors used are flex sensor, accelerometer, load cell [17].

3. DESIGNED SYSTEM

The designed system consists of following blocks:

Microcontroller ATMEGA 328

ATMEGA 328 is being used in proposed system as it is beneficial for handling all hardware and software programming of the crack detection of bridge. The Arduino is being used as well. As our requirement is being satisfied in ATMEGA 328 there is no need for going for higher end microcontrollers available. In build analog to digital converter is available as well this will help us in converting the sensor information from analog to digital in smooth manner.

The servomotor connected to the microcontroller will keep control on barricades if any crack occurs on bridge surface. If the bridge is not in state to travel from the alarm will be on and the LED indicators will turn to red for danger zone high alert.

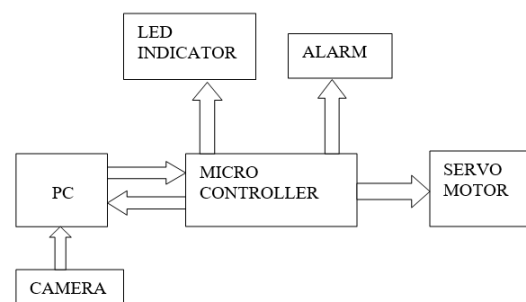

Fig. 1 Block Diagram of proposed System

Power supply

The power supply unit is used for supplying power to the circuit which we are designing. The power supply consists of transformer, rectifier, filter and a regulator. The transformer

is used for stepping down the 230V supply to useable voltage. The rectifier removes the ripples from the coming AC voltage. The filter makes pulsating AC voltage to DC voltage. And the regulator regulates the supply voltage.

Camera

The camera is being used for capturing images of the bridge. The camera which we are going to used is of 2MP which will be enough for detecting crack from the bridge surface. The images which we are going to capture will be directly send to computer and all the images captured will be collected and a pattern of images will be checked. If there is change in the pattern the algorithm will be processed and the authority will be informed about the crack occurred on the bridge.

4. METHODOLOGY

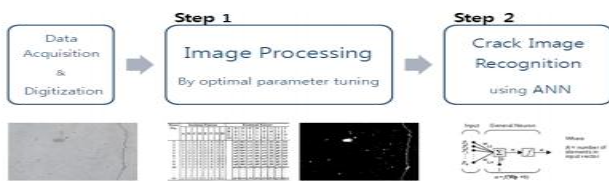

Fig. 1 Algorithm Architecture

Fig. 2 Algorithm Architecture

The methodology includes the steps such as capturing images, then grey scale conversion will be done of the image, then algorithm will be implemented, database will be compared and result will be shown on the PC whether the crack is detected or not.

First of all the camera will get started and the image will get captured from the camera. The captured image will be send to the PC and the PC will check the image. If the crack is detected we will make an algorithm and the character C will be passed so that the microcontroller get to know that the crack is detected. If the crack is not detected then the camera will operate normally and we will go back to capturing the image of the bridge surface.

The load cell connected in the circuit will be calibrated, if the weight of vehicle is less than that of threshold value which we have set then vehicle will be allowed to pass through the bridge. And if the vehicle load increased from the threshold value then the servomotor will turn on and the barricades will be operated and gates will be closed and vehicle will not be allowed to pass from that bridge.

If the crack captured by the camera is very tiny then the bridge will not turn closed instantly the passenger will be allowed to pass from that bridge to some limited time.

5. SIMULATION

The simulation which we have performed in this paper include Python and Proteus Software.

The output of python software is shown in figure 3. It contains Original Image, Cropped Image, Threshold Image, Mask Image, Edge Image Output Image. It also contains the output in form of the contours detected. It is also shown below in figure4.

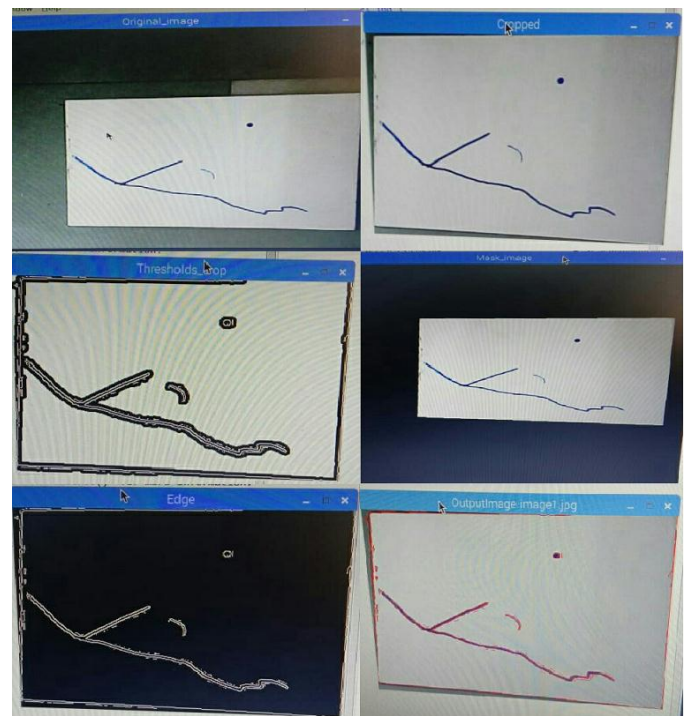

Fig. 3 Output of Python software program

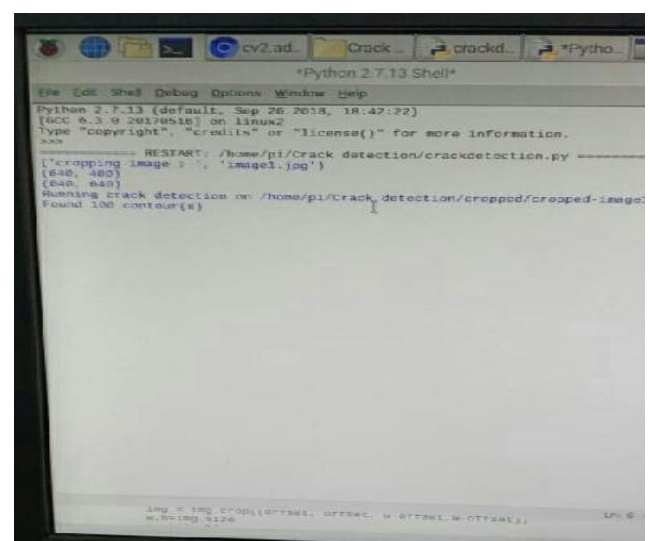

Fig. 4 Output of Python software program in contours

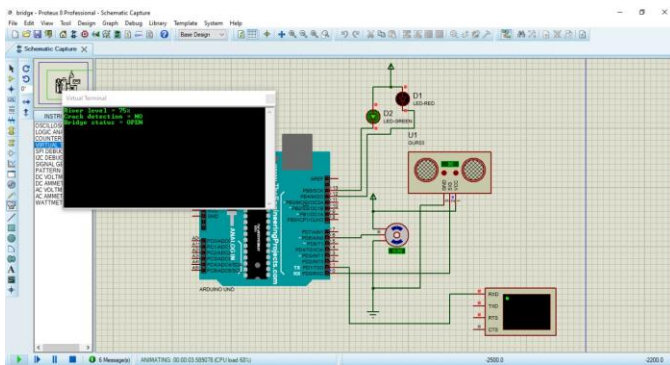

Fig. 5 Output of Proteus software

The simulation is performed on one part of the project and the output is taken from the simulation process.

6. CONCLUSIONS

1. We can conclude from above outputs that crack detected can be successfully done via bridge crack detection.
2. Image will be shown on GUI with crack size highlighted by contour.
3. Status of barricades and signal also give us proper outcomes.

REFERENCES

- [1] Shengyuan Li and Xuefeng Zhao, Image-Based Concrete Crack Detection Using Convolutional Neural Network and Exhaustive Search Technique, Hindawi Advances in Civil Engineering, Volume 2019, Article ID 6520620.
- [2] Liyan Zhang, Guanchen Zhou, Yang Han, Honglei Lin, And Yuying Wu, Application of Internet of Things Technology and Convolutional Neural Network Model in Bridge Crack Detection, IEEE volume 6, 2018.
- [3] Youfa Cai, Xing Fu, Yanna Shang, Jingxin Shi, Methods for Long Distance Crack Location and Detection of Concrete Bridge Structures, IEEE conference 2018.
- [4] Sheerin Sitara. N, Kavitha. S, Raghuraman. G, Review and Analysis of Crack Detection and Classification Techniques based on Crack Types, IJAER, Volume 13, 2018.
- [5] Hyunjun Kim, Eunjong Ahn, Myoungsu Shin and Sung-Han Sim, Crack and Noncrack Classification from Concrete Surface Images Using Machine Learning, SAGE 2018.
- [6] Zhong Qu, Fang-Rong Ju, Yang Guo, Ling Bai, Kuo Chen, Concrete Surface crack detection with the improved pre-extraction and the second percolation processing methods, Research Article, 2018.
- [7] Partha Pratim Ray, Mithun Mukherjee and Lei Shu, Internet of Things for Disaster Management: State-of-the-Art and Prospects, IEEE Volume 5, 2017.
- [8] Prateek Prasanna, Kristin J. Dana, Nenad Gucunski, Basily B. Basily, Hung m. La, Ronny Salim Lim, and Hooman Parvardeh, Automated Crack Detection on Concrete Bridges, IEEE 2014.
- [9] Sukalpa Chanda, Guoping Bu, Hong Guan, Jun Jo, Umapada Pal, Yew-Chaye Loo, and Micheal Blumenstein, Automatic Bridge Crack Detection- A Texture Analysis-Based Approach, ANNPR Springer 2014.
- [10] XU Xue-jun, ZHANG Xiao-ning, Crack Detection of Reinforced concrete bridge using video image, Springer 2013.
- [11] Gaurav Agrawal, Yogesh Jadhav, Sreeranjini Nair, Anurag Kumar, Prof. Sinu Nambiar, IOT Based Bridge Safety Monitoring System, IJRASET April 2019.
- [12] Snehal Sonawane, Nikita Bhadane, Sayali Zope, Ashitosh Pangavhane and V.S.Tidake, Design of Bridge Monitoring System based on IoT, MVP Journal of Engineering Sciences, June 2018.
- [13] Amrita Argade, Sanika Chiplunkar, Rohini Kumbhar, Varsha Kusal, Prof. Swati A. Khodke, Real Time Bridge Monitoring and Alert Generation System Using IoT, OAIJSE, May 2018.
- [14] Prof. N. W. Dangare, Ghadge Sonali, Khandge Tejas, Pathare Nisha, Patil Laxman Survey on IOT Based Bridge Monitoring System, IJIRCCCE, vol. 6 2018.
- [15] Jin-Lian Lee, Yam-Yauan Tyan, Ming-Hui Wen, Yun-Wu Wu, Development of an IoT-based Safety Monitoring System, IEEE-ICASI 2017.
- [16] Varsha Kusal, Amrita Argade, Sanika Chiplunkar, Rohini Kumbhar, Swati A. Khodke, Bridge Monitoring and Alert Generation System Using IoT, IJARIIIT 2017.
- [17] Shachi P., Manjunatha S., Automatic Bridge Health Monitoring System Using Wireless Sensors, IJSR, June 2017.