

# HYBRID POWER GENERATION USING WIND AND SOLAR ENERGY

M Sushmitha<sup>1</sup>, S Jaisiva<sup>2</sup>

<sup>1</sup>UG Student, Department of EEE, IFET College of Engineering, Tamil Nadu, India

<sup>2</sup>Assistant Professor, Department of EEE, IFET College of Engineering, Tamil Nadu, India

\*\*\*

**Abstract** - The demand for electricity is increased phenomenally over the past few decades. Also, the available conventional energy resources are depleting day by day. So, there is a need to switch over to non-conventional energy sources and utilize it in a most efficient manner. Such a situation leads to combining more than one non-conventional resources to produce electricity which is fairly known as hybrid energy system. To improve the results of such a system there are several methods adopted. In this project both solar energy and wind energy are used for producing the electrical energy. The efficiency of the system is increased by the help of implementing a tracking system for solar panels to rotate towards high solar radiation absorption region and additionally a DC - DC boost converter is used to increase the power output from the obtained solar energy which leads to overall power output producing rate that are obtained previously implemented methods.

## 1. INTRODUCTION

Energy is very important to the economic growth and social development of any country. Indigenous energy resources need to be developed to the optimum level to decrease dependence on imported fuels, subject to resolving economic, environmental and social constraints. In the current era, Wind and solar energy are becoming popular owing to abundance, availability and ease of harnessing for electrical power generation. This project proposes a hybrid energy system comprising PV panels and Wind power system which acts as an small scale electric power source. The main Function of the hybrid energy system is it collects energy from both the wind and solar power system with the help of wind turbines and PV panels respectively. Renewable energy obtained from solar and wind energy system are free to use, clean and very efficient energy to use. Due to increase in power demand in remote as well as urban areas several effective techniques are used to harvest the energy from the naturally available systems like solar and wind. Also, these hybrid systems eliminate the dependents of remote villages that are unable to supply by the main line services by implementing a standalone hybrid energy system. Hence these type of hybrid systems makes the global researchers to focus on advancing these systems and utilize it in an effective way.

## 2. SOLAR AND WIND ENERGY SYSTEM

The sun is a continuous fusion reactor in which hydrogen combines to form helium liberates large amount of heat. This heat energy in the sun rays can be collected by PV panels which generates electrical power by the principal of photovoltaic effect. Photovoltaic effect converts directly sunlight into electricity with the help of solar cells. According to our demand several types of cells are connected together by different type of connection strategy. This led to produce required voltage and current and it can be stored in battery or supplied to the system with the help of power electronic conversion techniques. Also, sun is the main reason for wind energy availability. The wind pressure difference makes the wind turbine blades to rotate and converts the kinetic energy into mechanical energy. This mechanical energy can be converted into electrical energy with the help of electrical generator. However, the wind availability is uneven and not so high. Hence, we can get generate only low power.

## 3. LITERATURE REVIEW

### 3.1 MPPT Algorithm

In order to obtain maximum power from a solar panel use of MPP algorithm is required. Over the past few decades several methods to find MPP has been introduced. This method differs in many aspects such as sensor, complexity, cost, convergence speed, requirement and availability of hardware module etc., Fuzzy Logic, InCond, P&O are the most popular MPPT algorithm because of their simplicity and finding the real MPP. Of which InCond and P&O are hill climbing technique. When irradiation is constant these two techniques are providing good performance. They are based on hill climbing principle which consists of moving the operation point of the PV array in the direction in which power increases.

### 3.1.1 Perturb and Observe

In this technique, the sign of the last perturbation and the sign of the last increment in the power are used to decide what the next perturbation should be. If there is an increment in the power, the perturbation should be kept in the same direction and if the power decreases, then the next perturbation should be in the opposite direction. Based on this strategy, the algorithm is implemented. The process is repeated until the MPP is reached. Then the operating point oscillates around the MPP. This problem is common also to the InCond method.

### 3.1.2 Incremental Conductance

The incremental conductance algorithm is based on the fact that the slope of the curve power vs. current(voltage) of the PV module is zero at the MPP, positive (negative) on the left of it and negative (positive) on the right.

- $\Delta I(\Delta V)/\Delta P = 0$  at the MPP
- $\Delta I(\Delta V)/\Delta P > 0$  on the left
- $\Delta I(\Delta V)/\Delta P < 0$  on the right

By comparing the increment of the power vs. the increment of the current(voltage) between two consecutive samples, the change in the MPP voltage can be determined.

### 3.2 Fuzzy Logic

The use of fuzzy logic was popular in the last few decades because they can deal with imprecise inputs, no need of accurate mathematical model also they can handle nonlinearity. These systems were mainly categorized into three stages: fuzzification, inference system and defuzzification. The inputs of the fuzzy controller are usually an error, E, and the change in the error,  $\Delta E$ . The error can be chosen by the designer, but usually it is chosen as  $\Delta P/\Delta V$  because it is zero at the MPP. Then E and  $\Delta E$  are defined as follows

$$E = \frac{P(k) - P(k-1)}{V(k) - V(k-1)} \quad (1)$$

$$\Delta E = E(k) - E(k-1) \quad (2)$$

The output of the fuzzy logic converter is usually a change in the duty ratio of the power converter,  $\Delta D$ , or a change in the reference voltage of the DC-link,  $\Delta V$ . The rule base, also known as rule base lookup table or fuzzy rule algorithm, associates the fuzzy output to the fuzzy inputs based on the power converter used and on the knowledge of the user. Table I shows the rules for a three phase inverter, where the inputs are E and  $\Delta E$ , as defined in (1) and (2), and the output is a change in the DC-link voltage,  $\Delta V$ .

$E/\Delta E$	NB	NM	NS	ZE	PS	PM	PB
NB	NB	NB	NB	NB	NM	NS	ZE
NM	NB	NB	NB	NM	NS	ZE	PS
NS	NB	NB	NM	NS	ZE	PS	PM
ZE	NB	NM	NS	ZE	PS	PM	PB
PS	NM	NS	ZE	PS	PM	PB	PB
PM	NS	ZE	PS	PM	PB	PB	PB
PB	ZE	PS	PM	PB	PB	PB	PB

Table I

In table I seven levels are used : NB (Negative Big), NM (Negative Medium), NS (Negative Small), ZE (Zero), PS (Positive Small), PM (Positive Medium) and PB (Positive Big).

### 3.3 PIC16F877A - Microcontroller

PIC16F877A is the heart of this system. It consists of clock circuit and power on reset circuit. Clock circuit is build around crystal oscillator and ceramic capacitor. Purpose of crystal oscillator is to stabilize the frequency and the capacitor is to stabilize the amplitude if the clock. This circuit determines the operating speed. Here we use 4MHz crystal oscillator, so the microcontroller will work at the speed of 1uSec. Purpose of the microcontroller is to control the speed of the DC shunt motor according to the load. It uses internal ADC and complete one port for reading load and control the speed. That it reads voltage output and produces the digital output according to this input voltage. This microcontroller will set the load limit and terminate the DC shunt motor to prevent from over load.

### 4. PROPOSED SYSTEM

In these proposed wind - PV system the energy trapped by the PV panels are stored in the battery via the bi-directional converter. The bi-directional will charge from the PV panels or discharge to the load according to the energy available in the battery. MPP tracker continuously finds the maximum power point and traps the sunlight. The obtained dc power is stepped up to a higher level with the help of DC-DC boost converter. In wind system the energy generated by the wind side generator system is AC. This AC power is transformed into DC with the help of AC-DC converter. The converted DC is stepped to a higher voltage again with the help of a boost converter. The wind energy obtained as AC power is finally converted to a higher level of DC power. This higher level DC power is stored in battery and it is transferred to the load whenever the demand arises. The block diagram of the proposed system is shown in Fig 1. The hardware module of the proposed system is shown in Fig 2.

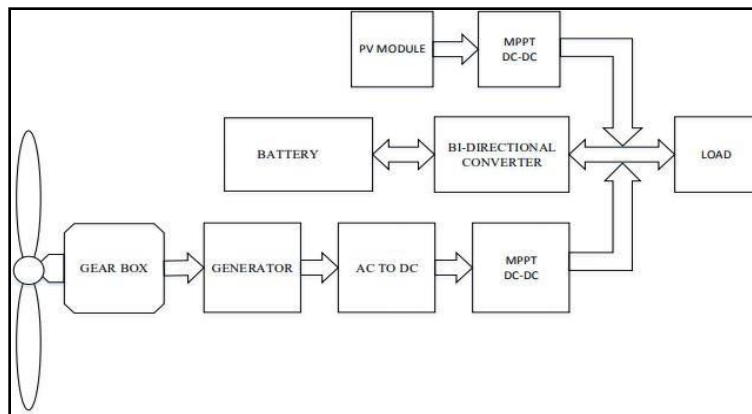

Fig - 1: Block Diagram of Proposed System



Fig - 2: Hardware module of Proposed system

## 5. CONCLUSION

The proposed system is implemented with the help of a PIC microcontroller. Also, the power output obtained from the is effective to supply the load demand. With the help of advanced control strategies there is a possibility to increase the efficiency of the system and that could be achieved in the future work.