

Design and Analysis of a Drivetrain of an Electric Formula Student Vehicle

Shiraz Sajid Hashmi¹, Md Hassaan², Fardeen Nayeem³, Aarish Afsar⁴

^{1,2,3,4}Student, Department of Mechanical Engineering, Faculty of Engineering & Technology, Jamia Millia Islamia, New Delhi, India

Abstract - In this paper, we have discussed the theory and analysis of the drivetrain system of an electric Formula Student Vehicle that incorporated a student-developed system. The paper discusses the theory and basic design criteria of the drivetrain that is used to transmit the power and torque to the wheels and tyres. The main objective of the paper is to design a feasible, achievable vehicle with the budget we have to complete the vehicle in to compete in the Formula Bharat 2021 Competition. The Power to weight ratio has to be increased as much as possible with keeping the vehicle as light as possible without compromising driver's safety. All the designs were made by strictly following Formula Bharat 2021 Electric Vehicle specifications described in 2021 rulebook.

Key Words: Drivetrain, Formula Bharat, Electric Vehicle, SolidWorks, Ansys

1. INTRODUCTION

While designing, developing and fabricating any vehicle, the drivetrain plays a vital role. As it makes power transmission accessible. Power transmission has to be through various components and parts. It depends on us actually to design this system of various components and parts in such a way that maximum power is transmitted with minimum loss and gives the vehicle the motion it requires. This drivetrain system consists of a single motor setup with the half-shaft rear axle system. Considering the affordability and feasibility of the project while being competitive as well, we have researched every option available in the selection of material and components and picked or customized if needed to suit our best interests. After the completion of designing the drivetrain, we must meet the requirements we approached first and to ensure that several design and analyses methods and software were applied.

2. Methods Approached

The project criteria are satisfied with each design that we have made, following Formula Bharat 2021 rulebook. The modelling of each component was mostly made in SolidWorks. The stress analysis and Factor of Safety Distribution of the components was done in either Ansys or SolidWorks. GearTrax was used to model Sprockets driver and driven and Optimum G for the Lap Simulations and for the vehicle performances.

All our results are verified with all the software and calculations with the datasheets available of each material and components that we have used while considering the performance and durability also in the tests with satisfying all the rules and criteria and maintaining driver's safety.

3. Drive Train

The drivetrain is a system which transmits power throughout a vehicle, it turns motor power to rotate the wheels and moves the vehicle.

We have used the datasheet available with the Emrax 188 for the calculations and simulation of power and torque to meet the final result.

Components of the Drivetrain, Emrax 188 single setup motor, Chain Sprocket assembly, A Spool differential and Half Shaft axle with Tripod joints.

Table -1: Drivetrain Specification

Motor	Emrax 188
Efficiency of motor	92% to 98%
Gear ratio(i)	4.9
EV weight (W)	310 kg
Peak Motor Torque	90 Nm
Continuous Motor Torque	40 Nm
Peak Motor Power	52 kW
Continuous Power	Up to 30 kW
Battery Capacity	78.4C(19.6 x 4)
Nominal DC Voltage	348V
Specific Load Motor Speed	15 RPM/Vdc
Centre of Gravity Height	288 mm
Centre of Gravity front wheel	876 mm
Tyre	20-7.5/13

3.1 Layout Drawings

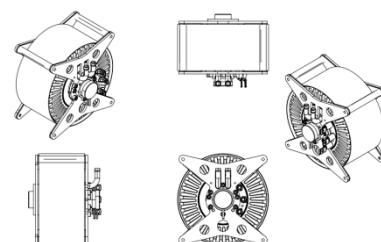

Fig. Motor Assembly

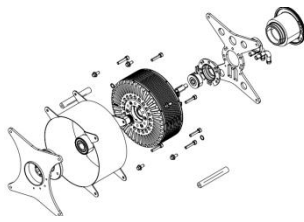

Fig. Motor Assembly Exploded View

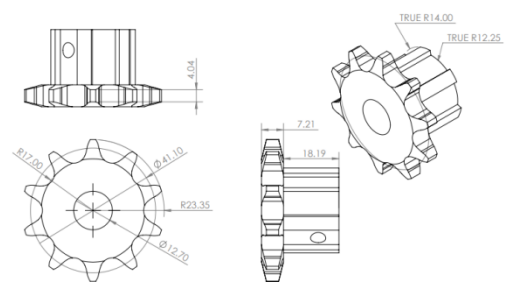

Fig. Front Sprocket

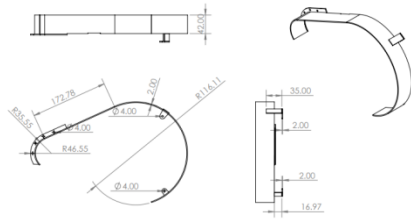

Fig. Chain Guard

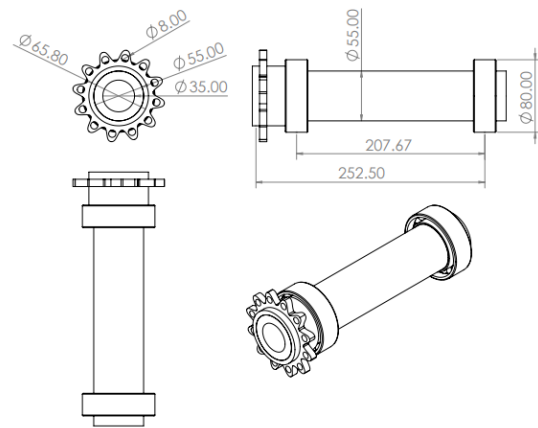

Fig. Spool Differential

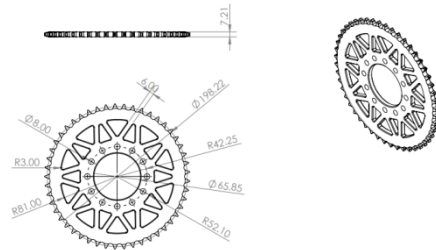

Fig. Rear Sprocket

3.2 Analysis of Sprocket

We use ANSYS for the analysis and acceptance of the design. The design has been, topologically enhanced as it needed to be as fewer parts in the assembly weighs extra. Loads on moving parts are higher than expected, a bit of compromise has also been adjusted with energy efficiency.

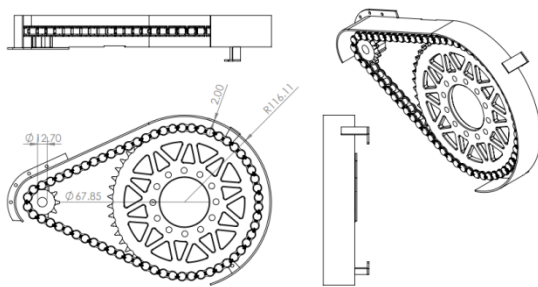

Fig. Chain Sprocket Assembly

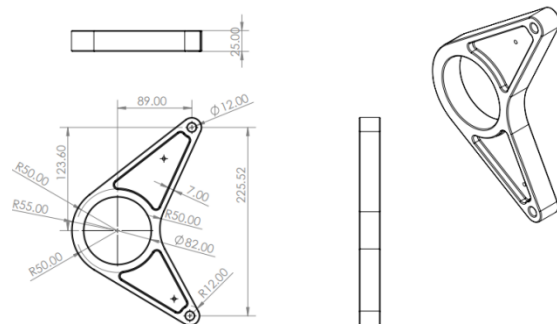

Fig. Differential Mount

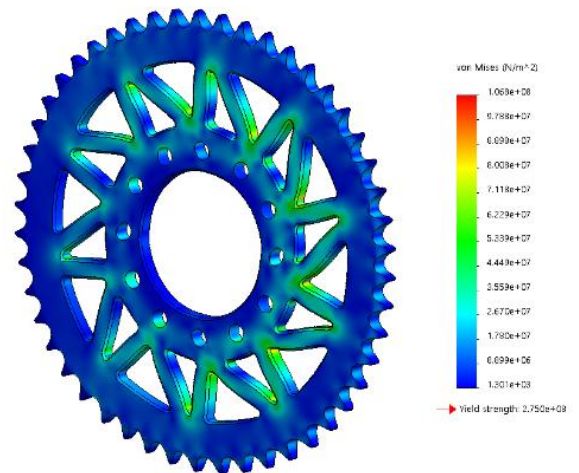

Fig. Stresses on Sprocket

Material used: 6061-T6 Aluminum

1. Driver
 - No of teeth = 10, Pitch:1/2"
 - Outside Diameter: 1.618033988749895"
2. Driven
 - No of teeth = 49, Pitch:1/2"
 - Outside Diameter: 7.803937619544856"

Force calculation on sprocket teeth-

Max Torque of motor = 90 Nm

Force on Driver sprocket = (torque on sprocket) / (radius of driver sprocket)

$$= 90/0.02 = 4500N$$

Driver Teeth in which force applied = 5

Force on one teeth of Driver sprocket = (Force on Driver sprocket) / (no of teeth (n))

$$= 4500 / 5 = 900 N$$

Driven Teeth in which force applied = 30

Force on one teeth of Driven sprocket = (Force on Driven sprocket) / (no of teeth(N))

$$= 4500 / 35 = 128.50 N$$

3.3 Analysis of Differential Mount

The differential mount is a part which carries the differential and holds it. It's mounted on either side of the differential with deep-grooved bearing with in to keep the motion smooth.

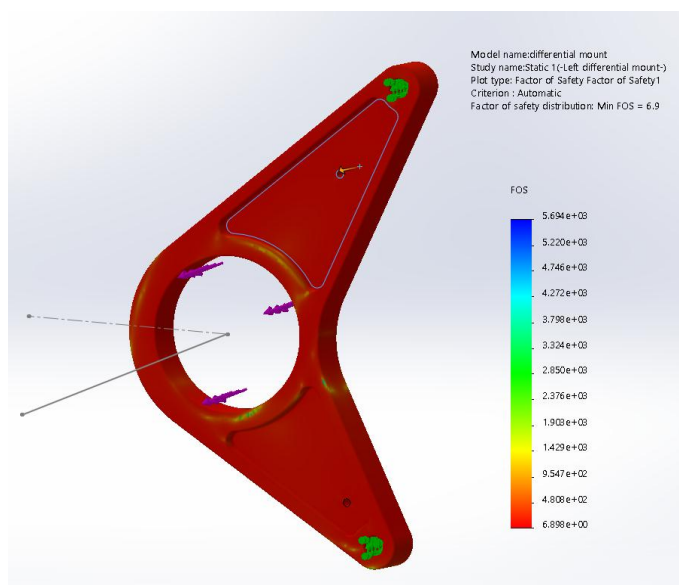

Fig. Factor of Safety distribution

Material used: 6061-T6 Aluminum

Minimum Factor of Safety: 6.9

Bearing force calculation on Differential Mounting

Torque from Motor = 85.5 Nm

Gear ratio = 4.9

Max wheel torque = 419 Nm (85.5x4.9)

Sprocket radius (Driver) = 0.02m

Force on chain = 4500 N

Bearing load on chain end = (Force on chain) x ()

$$= (4500 \times 252.5) / 207.67$$

$$= 5471.42 N$$

Resolving vertically = (Bearing load on chain end) x (sinQ)

$$= 5471.4 \times \sin (24.45)$$

$$= 2264.6 N$$

Resolving horizontally and divided by 2 for symmetry

$$= (5471.4 \times \cos (24.45))/2$$

$$= 2490 N$$

Bearing load on non-chain end = (4500x44.96) / 207.67

$$= 974.2 N$$

Resolving vertically = 974.2 x (sinQ)

$$= 403.2 N$$

Resolving horizontally and divided by 2 for symmetry = (974.2 x (cosQ)) / 2

$$= 443.4 N$$

4. Lap Simulation

For the lap simulation, Optimum G is used, As Optimum G is Designed for the Combustion Engine Systems, by replacing the Fuel to lithium Battery, we utilized it for the Electric Vehicle.

As our Vehicle has Auto-Transmission Gear System with no gearbox, The First gear ratio is set to be 1, and the final drive ratio, 4.9, the gear ratio we have come on the conclusion was kept.

The results from Optimum G cannot be blindly trusted so we have taken them as approximation and carried it in our design.

Performance Metrics

Metric	Value
Top Speed	127.02 km/h
Time for 0 to 100 km/h	6.07 s
Time for 100 to 0 km/h	6.69 s
Lateral Acceleration - Skidpad 50 m	5.89 m/s ²

Fig. Performance Metrics calculated by Optimum Lap

3. Automotive Transmissions Fundamentals, Selection, Design & Application by Gisbert Lechner, Harald Naunheimer
4. Design and Theory of Powertrain of Formula Student {FSAE} IRJET-V6I4991 Car by D.A. Sawant¹, Shreyash Sanjay Ghodke², Pratik Gajanan Thorat³, Pravin Mohan Balgore, Madhusudan Uttam Bichkar, Bhavik Kishor Patel

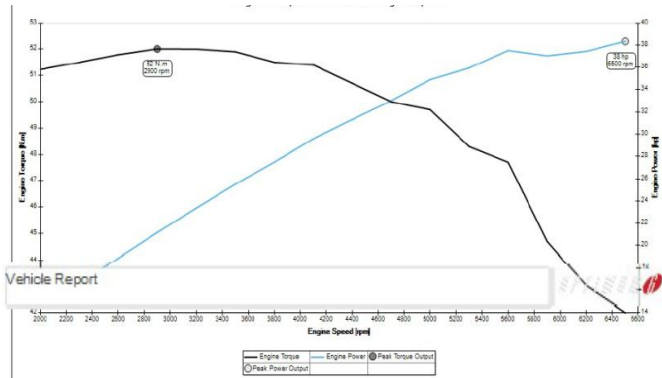

Fig. Motor Torque and Power vs Motor Speed

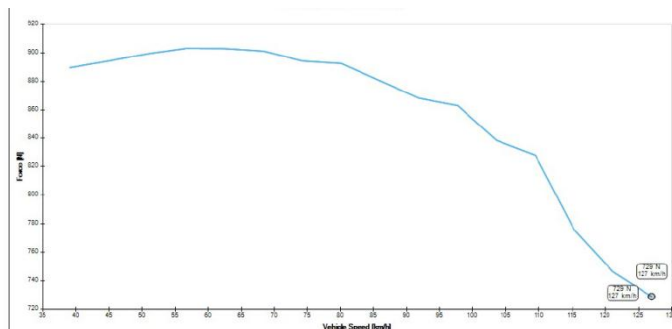

Fig. Tractive Force at Wheels

5. CONCLUSIONS

We have designed the drivetrain of an Electric Formula Student race vehicle. We have fulfilled all the criteria asked by the Formula Bharat Rulebook 2021 without compromising driver's safety while maintaining Power to Weight ratio with the most feasible and achievable design with making the design as in the budget too.

REFERENCES

1. Design and Development of the Electrical System in an Electric Formula SAE Car by Matt Barham University of canterbury, Christchurch, New Zealand, 2017.
2. Formula Electric Drivetrain Final design report, University of California, Davis, March 21, 2014