

AUTOMATED ENERGY MONITORING SYSTEM AND POWER FACTOR IMPROVEMENT

Mr. Manish B. Zode¹, Mr. Aditya B. Dhanke², Ms. Shital V. Uike³, Prof. N. V. Yawale⁴

^{1,2,3}UG Students, Electrical Engineering, DES'sCOET, Dhamangaon Rly, Maharashtra (India)

⁴Assistant Professor, Electrical Engineering, DES'sCOET, Dhamangaon Rly, Maharashtra (India)

Abstract - Generation of power at present is decisive as wastage of power is a global concern. Power factor measures and power efficiency is an important aspect in improving the quality of supply. In most power systems, a low power factor resulting from an increasing use of inductive loads is often overlooked. A power factor correction unit would permit the system to improve its power factor close to unity for economical operation. The advantages of correction of power factor include reduced power system losses, increased load carrying capabilities, improved voltages and much more. The aim of this seminar is to build an Automatic Power Factor Correction Unit, which is able to monitor the energy consumption of a system and automatically improve its power factor. An open source energy monitoring study was implemented in the design for accurate power calculation. The APFC device measure the reactive power consumed by a system's inductive load and compensates the lagging power factor using capacitance from a capacitor bank.

Key words:

Alternating current, Current Transformer, Potential Transformer, Power Factor, Power Factor Correction.

1. INTRODUCTION

Power factor is defined as the ratio between the actual load power and the apparent load power drawn by an electrical load. It is simply a measure of how efficient the load current is being converted into useful work output. The power factor of a system less economically operates. A low power factor can be the result of a significant phase difference between voltage and current load terminals a high harmonic content or even a distorted current waveform. Generally it is the value of inductive loads such as induction motor power transformers or induction furnaces that causes a current to lag behind voltage. A low power factor resulting from inductive loads can be improved by power factor correction method but a poor power factor resulting from distorted current waveform requires a change in equipment design or addition of harmonic filters. Since power factor in inductive loads is generalised. they have to be given with reactive power in order to reduce increased power consumption of the machine.

All inductive loads require active power to perform the actual work and reactive power to maintain the magnetic field. This reactive power is necessary for the equipment to operate, but imposes an undesirable burden on the supply

causing the current to be out of phase with the voltage. Low power factor can also result when inactive motors work at less than full load such as a surface grinder performing a light cut a circular saw that is only resolve, an air compressor that is unloaded etc. Losses generate by low power factor are due to the reactive current flowing in the system and can be eliminated using PFC.

Power factor correction is the process of compensating a lagging current by a leading current through connecting capacitance to the supply. Capacitors contained in most power factor correction system carry current that leads voltage and produces a leading power factor. A sufficient capacitance is connected so that power factor is adjust as close to unity as possible. Theoretically capacitors could provide 100% of the needed reactive power however practically correcting power factor much nearer to unit may result in harmonic distortion. If capacitors are connected to a circuit that operates nominally at a lagging power factor the extent to which the circuit lags will reduce proportionately. Power factor correction is applied to neutralize as much of the magnetizing current as possible and to reduce losses in the distribution system. It action many benefits to the economic electrical consumer including reduced utility bills by eliminating charges on reactive power, reduced losses making extra KVA available from the existing supply. thus it improves energy efficiency this system is based on technique of continuous monitoring of the systems parameters such as voltage and current with the use of potential transformer and current transformer respectively. Through continuous monitoring phase difference between the two quantities will be calculated continuously and depending upon phase difference correspondingly suitable amount of capacitors will be switched on or off in the system in line to improve power factor as close as unity. As there is no moving part in capacitors hence switching losses are less as compare to that of static compensation also no extra motor is required for power factor correction and hence amount is much less as compare to that of power factor correction.

2. Existing System

There are several existing procedures for power factor correction in modern days.

A. Synchronous Condenser

It is synchronous motor that rotates under no load condition. Asynchronous motor shows capacitive behavior

while operating in over-excited mode. By controlling the field excitation power factor can be adjusted continuously. It provides step-less PF correction and not affected by system harmonics. But its installation and maintenance is costly

B. Static Capacitor Bank

Capacitor causes leading power factor as it shifts current ahead of the voltage. So to correct lagging power factor, it is a convenient method for which this method is practiced worldwide vastly. Though it has some limitations like the inability to absorb harmonics and doesn't provide step-less correction, it is a popular choice for PFC for its low cost of installation and maintenance

3. Working of Proposed System

3.1: Power Supply: The AC mains can supply an AC power of 230V at 50Hz frequency. But it requires DC power in order to operate the modules. A voltage transformer is used to step down the 230V supply to 12V. This AC signal is then converted to DC through a bridge rectifier followed by clean capacitors. The final stable DC outputs are achieved using voltage regulator IC.

3.2: Voltage Sensor Circuit: The mains 230V AC is stepped down to 12V AC. A voltage divider circuit divides this 12V in 1:10 ratio which provides around 1.2V sinusoid signal. A DC offset of 2.5V is applied to the sinusoidal signal. As a result the whole sinusoid can be observed in the positive boundary and the microcontroller can read the whole sinusoid signal through its analog input.

3.3: Current Sensor Circuit: The current signal flowing through the mains is retrieved through a current transformer. A burden resistor transforms the current signal into a voltage form that perform the properties of the current sinusoid. ADC offset voltage of 2.5V is applied to the sinusoidal signal so that the reference point is lifted up and the whole sinusoid can be read in analog mode within its operating range.

3.4: Inductive Load Network: The inductive load network is a combination of loads having inductive characteristics and consuming huge electrical power due to lagging power factor. The network collectively simulates a highly inductive load controlling at a very low power factor.

3.5: Relay Drivers: The loads and capacitors are connected to a high voltage circuit. In order to appropriate these high voltage components with microcontroller relay is used for convert operation on capacitors in high voltage circuit through the control signal from microcontroller keeping the microcontroller safe and electrically isolated from high voltage.

3.6: Display: The calculated power parameters current power factor mains voltage mains current real and apparent power are continuously displayed on a 20x4 Liquid Crystal Display monitor

3.7: Capacitor Bank: Capacitor bank is the collection of capacitors of different values. Series and parallel combination of different capacitor provide a range of capacitance required to compensate poor power factor. The sizing of capacitors is determined based on the required KVAR expect by the load network.

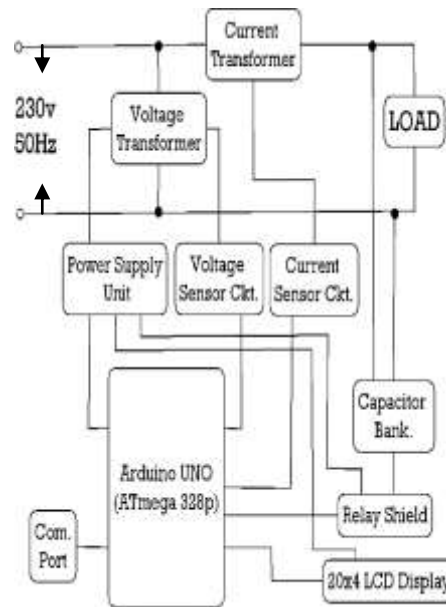

Fig.1: Block Diagram of the APFC and Energy Monitoring System

4. Circuit Components

4.1: Power Factor Correction

Automatic Power Factor detection and correction operates on the principal of constantly monitoring the power factor of the system and to initiate the required correction in case the power factor is less than the set value of power factor. The current and voltage signals are sampled by employing instrument transformers connected in the circuit. The instrument transformers give stepped down values of current and voltage, whose magnitude is directly proportional to the circuit current and voltage. The sampled analog signals are converted to suitable digital signals by the zero crossing detectors, which changes state at each zero crossing of the current and voltage signals. The ZCD signals are then added in order to obtain pulses which represent the time difference between the zero crossing of the current and voltage signals. The time period of these signals is measured by the internal timer circuit of the Arduino by using the function pulse in which gives the time period in micro seconds. The time period obtained is used to calculate the power factor of the circuit.

4.2: Voltage Sensing

The transformer used for this project is a step-down transformer. The potential transformer is fed with alternating voltage with a value of 220V and the value is step

down to less than 5V. The output of the transformer is connected to diode. The diode act as rectifier which converted the voltage wave into pulsating D.C. wave to be detected by the microcontroller. The output of the diode is then connected to the zero-crossing detector where zero crossing detection is used to sense sine wave zero crossing from positive half cycle to negative half cycle or vice-versa

4.3: Current Sensing

The current sensing circuit works the same as voltage sensing circuit but this circuit detects current. The input signal is connected to the step down current transformer where it converts high current in to low current output for the use of different electrical circuits. The reason current transformer is used because, Op-amp requires current less than 50mA. Output of current transformer is connected to diode. Diode function as a rectifier in the circuit and it is connected to zero-crossing detector. This zero-crossing detector detects sine wave zero crossing

5. CONCLUSIONS

It is concluded that automatic power factor correction techniques can be applied in industries, commercial lines and power distribution system to increase stability and efficiency of the system. The APFC device helps to pull in high current drawn from the system and reduce charges on utility bills. A reduced power consumption results in lower greenhouse gas emissions and fossil fuel depletion by power stations and would benefit the environment.

6. ACKNOWLEDGEMENT

We take this opportunity to express our gratitude and indebtedness to our guide prof. N. Yawale Assistant Professor, Electrical (E & P) department, who is a constant source of guidance and inspiration in preparing this work.

We express our sincere gratitude towards H.o.D., Prof. P. V. Raut, and Assistant Professor whose constant help and encouragement helped us to complete our Project report. We are grateful to Dr. L. P. Dhamande, Principal for his encouragement and support.

We are also thankful to all the staff members of Electrical (E & P) department, whose suggestions helped us to complete the Project Work.

REFERENCES

[1]Anant Kumar Tiwari, Durga Sharma, Vijay Kumar Sharma (2014) "Automatic power factor correction using capacitive bank." Int Journal of Research and Applications, Volume-4, 2014, pp.393-395.

[2] Barsoum, Nader (2007) "Programming of PIC Micro-Controller for Power Factor Correction" IEEE Conference on Modeling & Simulation, Pages:19-25.

[3]Dr. Kurt Schipman and Dr. Francois Delince, "The importance of good power quality", ABB power quality Belgium.

[4] Jones, L. D.; Blackwell, D. (1983) "Energy Saver Power Factor Controller for Synchronous Motors", IEEE Transactions on Power Apparatus and Systems, Volume: 5, Issue: 5, Pages: 1391-1394.

[5] Jos Arrillaga, Neville R. Watson (2003). "Power System Harmonics" 2nd.ed. Chichester: John Wiley

[6]Keith Harker (1998). "Power System Commissioning and Maintenance practice." London: Institution of Electrical Engineers.

[7] Md. Shohel Rana, Md. Naim Miah & Habibur Rahman, "Automatic Power Factor Improvement by using Microcontroller" Volume 13 Issue 6 Version 1.0 Year 2013 from University of Engineering & Technology Rajshahi- 6204, Bangladesh.

[8]Mr. Satyasuranjeet Behera, Mr. Sibasis Mohapatra, Mr. Monalisa Bisoi "Automatic Power Factor Correction by Microcontroller 8051". Department of Electrical Engineering, National Institute of Technology, Rourkela.

[9] Rakendu Mandal; Sanjoy Kumar Basu; Asim Kar; Shyama Pada Chowdhury (1994) "A Microcomputer – Based Power Factor Controller", IEEE Transactions on Industrial Electronics, Volume: 41, Issue: 3, Pages: 361–371.

[10] Reetam Sen Biswas, Dr. Satadal Mal, Automatic Power Factor improvement using Microcontroller, Electrical Engineering, Heritage Institute of Technology, Kolkata.