

PLC Based Temperature Controlling using Peltier Element for Industrial Automation

Dr. S.P. Selvaraj, Mr. S. Dhashnamoorthy, Mr. M. Dhurun, Mr. V. Kishore

¹Dr.S.P.Selvaraj, Professor, EIE Department, Bannari amman Institute of Technology

^{2,3,4}EIE Department, Bannari amman Institute of Technology

Abstract - Temperature is the main parameter need to control in many industry for their industrial purpose of manufacturing and production. Temperature is controlled by using peltier element. Peltier element is controlled by PWM signal. PWM signal is generated by Programmable Logic Controller(PLC). Relay is used to change the polarity of the signal supplied to peltier element. On duty cycle of PWM signal is applied to the common terminal of the relay. Off duty cycle of PWM signal is applied to the negative terminal of peltier element. Positive terminal of peltier element is connected to the normally open contact terminal in relay. Whenever the relay is get energized, supply from common terminal is get transferred to normally open contact terminal. Now the PWM signal is supplied to peltier element through relay so that peltier element get activated by thermal energy by heating and cooling. When the relay get deenergized, common terminal is get contact to normally closed terminal. So the peltier element get deactivated from thermal energy. Relay is activated by switch, interfaced with PLC, to control the signal flow.

Key Words: pulse width modulation, PLC, relay, smps, peltier element.

1. INTRODUCTION

In early days, maintaining desired temperature for manufacturing and production is at very risk for the labours who are work in manufacturing and production industries. Introduction of PLC is the revolution in industries for automation. PLC can communicate with any kind of actuators, sensors and transducers. PLC can do arithmetic, counting, timer and sequencing on off control action. Pulse width modulation signal is the output from PLC. This is applied to the common terminal of relay. When the relay get energized, common terminal get contacted with normally closed terminal. Peltier element is one which absorb the heat at one junction and and release at another junction, when the electric current passes between the junction. Heating and cooling junction will change according to the polarity of the electricity that passes between the junction. On duty cycle of PWM signal is applied to the common terminal of the relay. Off duty cycle of PWM signal is applied to the negative terminal of peltier element. Positive terminal of peltier

element is connected to the normally open contact terminal in relay. Now the PWM signal is supplied to peltier element through relay so that peltier element get activated by thermal energy by heating and cooling. When the relay get deenergized, common terminal is get contact to normally closed terminal. So the peltier element get deactivated from thermal energy. Relay is energized by switch, it is interfaced with PLC, to control the switching action. According to the industrial need of desired temperature, voltage, current and frequency of the electric supply is changed which is directly proportional to the heat produced by the peltier element. Advantage for this method is to reduce the health injury to the labours who are all working in the manufacturing and production industries like wax manufacturing, brake pedal coating, plastic manufacturing, silver coating etc . . . and also peltier element will consume very much small energy for producing thermal energy. But in manual production of heat tends to consume much large amount of energy like liquid petrol, diesel, kerosene and much more fossil fuels, which leads to air pollution thus, pollution is controlled.

2. PROJECT OVERVIEW

In our project, programmable logic controller and peltier element lays a major role in the producing the thermal energy on the surface of area above the junction of peltier element. PWM signal is another factor that will control the heating and cooling on the peltier device. PWM signal generated by the PLC is depend upon the factor of voltage, current and frequency value. This factors value can be specified in the PLC programming. PLC is activated by the single phase power supply which is passes through the switched mode power supply which is used for the rectification of 230 volt AC power supply into 24 volt DC power supply with the amps rating of 5A. PLC device requires only 24 volt DC power supply. Controlling of peltier element is fully on the PLC programming which can be reprogrammed to for any other purpose. Relay is used to change the polarity of the PWM signal. Relay can be energized by the switch that is interfaced with PLC input terminal so that input signal is feed to PLC device by the action of switch.

3. METHODOLOGY

Programmable logic controller having extension module for generating pulse width modulation signal is connected with relay. Peltier element is connected to the relay. Relay is used for changing the polarity of the PWM signal that is applied to the peltier element. On duty cycle of PWM signal terminal in the PLC is connected to the common terminal of the relay, and off duty cycle of the PWM signal terminal on the PLC is connected to the negative terminal of peltier element. Positive terminal of peltier element is connected to the normally open contact terminal. When the relay get energized, common terminal of relay is get contacted with normally open terminal. On duty cycle timing and off duty cycle timing is defined in the PLC programming. In this configuration, PWM signal can flow into peltier terminals, thus producing the heat energy. This energy can be used for the desired industrial purpose.

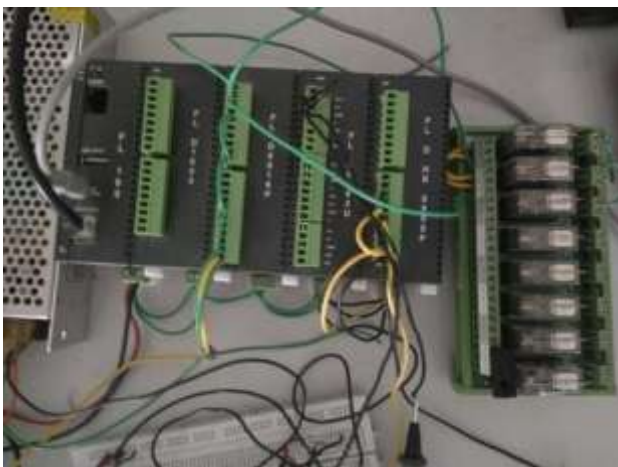

Fig-1 : Proposed Method

4. HARDWARE DESCRIPTION

Programmable Logic Controller, Relay, Peltier Element, SMPS are the hardware used in our project

4.1. Programmable Logic Controller

Programmable logic controller is invented in the late 1960's and in early 1970's by the use of inductors. But it has more complication on the industrial side by programming. Only high trained programmer can be modify or create the program for these PLC's and implement to industrial automation. But in 1978 processor based Programmable logic controller came into vision, that create the great revolution in the industrial automation. First of all, omron company is the one which introduce the programmable logic controller, that creates the industrial revolution. Modern

processor based PLC can do the operations like arithmetic, timing, counting, sequencing based on the programming. Several modern PLC can communicate other devices like Human machine interface, variable frequency drive and with some other controller. Following figure shows the PLC image.



Fig -2 : Programmable Logic Controller

4.2. Relay

Relay is the device which can be used for the amplification, switching purpose. It has five terminals namely normally open, normally closed, common terminals on the output side. Positive and negative terminals is on the input side for the energize purpose. When the relay is on the off state, i.e when there is no signal passes into positive and negative terminal of relay, common terminal is get contacted into normally closed terminal. At that time, power supply given to the common terminal get into normally closed terminal. When the signal passes into positive and negative terminal of PLC then it is said to be in on state. At this time, power supply given into common terminal get contacted with normally open terminal, supply given into common terminal is get into normally open terminal when the relay get energized. This is the working of the relay. Following figure shows the relay image



Fig -3: Relay

4.3. Peltier Element

Peltier element has two sides with the junction between two sides for the flowing of electricity. Whenever there is a flowing of electricity in the junction, heat is absorbed at one side called cold junction, and released at another side called heat junction. Rate of flow current in the junction of peltier determine the rate of heating and cooling at the sides of the peltier element. This is the basic principle discovered by Jean Charles Athanase Peltier in the year of 1834. Following figure shows the picture if peltier element following figure shows the peltier picture



Fig -4: Peltier Module

5. SOFTWARE DESCRIPTION

PLC programing can be done in the manufactures defined software. After the introduction of processor based PLC, high level computerized programming become more popular for configuration of PLC to the desired extent. Now the industrial automation is on the peak of the country's economy as well as individual's personal economy for the saving of unwanted expenditure, this automation is done by the introduction of computerized programming languages for different versions of PLC.

5.1 PLC Programming

When the input B0000 is set to be ON. Data from D0000 register is transferred to D0001 register. And the output B0001 is set to be ON. Next, the data from the register B0001 is transferred to the MW0402 register which performs the frequency action for pulse width modulation signal. Output is generated . The following figure shows the programming of PLC to configure the controller to generate the pulse width modulation signal.

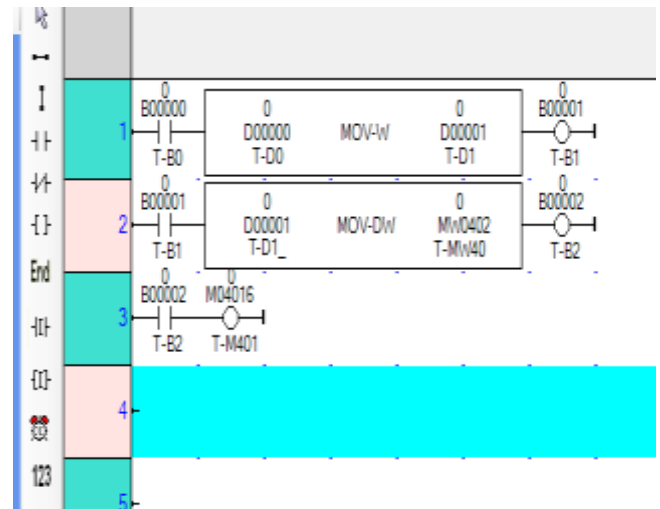

Fig -5: Programming

6. RESULT AND CONCLUSION

Thus, the temperature is controlled by PLC using peltier element. PWM signal plays a major role to control the peltier element. Voltage, frequency and current value of PWM signal determine the heating of peltier element. Following figure shows the PWM signal.

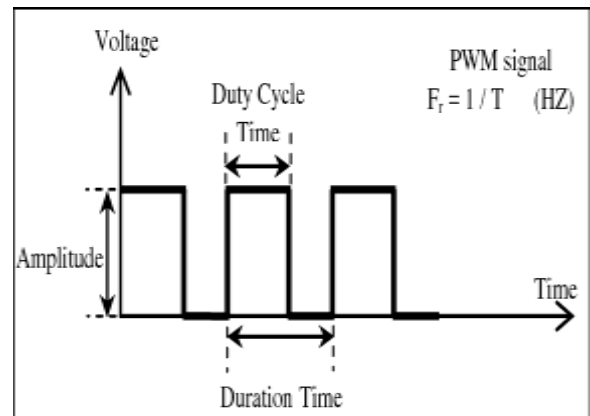

Fig -6: Pwm Signal

REFERENCES

- [1] J. C. Peltier. Nouvelles Experiences sur la Caloricite des Courants Electriques. Ann. Chim. Phys. 1834, 56, pp 371-386.
- [2] E. H. Lentz. Electrical Experiment of Academician Lentz. Water Freezing by Galvanic Stream. Bibliotec. Chten. 1838, 28, pp 44-48.
- [3] Jonathan Schoenfeld, Integration of a Thermoelectric Subcooler Into a Carbon Dioxide Transcritical Vapor Compression Cycle Refrigeration System, International Refrigeration and Air Conditioning Conference, 2008.

- [4] Michael Ralf Starke, Thermoelectrics for Cooling Power Electronics, The University of Tennessee, Knoxville, 2006.
- [5] Y.Y. Hsiao, W.C. Chang, S.L. Chen, "A mathematic model of thermoelectric module with applications on waste heat recovery from automobile engine" in Elsevier Journal of Energy volume 35 (2010) pages 447-1454.
- [6] AdithyaVenugopal, Karan Narang et al, "Cost-effective Refrigerator Using Thermoelectric Effect and Phase Change Materials", International Journal of Scientific & Engineering Research, Volume 5, Issue 2, February- 2014.
- [7] Nash, J. D., and J. N. Moum, 1999: Estimating salinity variance dissipation rate from conductivity microstructure measurements. J. Atmos. Oceanic Technol., 16, 263-274.
- [8] Oakey, N. S., 1982: Determination of the rate of dissipation of turbulent energy from simultaneous temperature and velocity shear microstructure measurements. J. Phys. Oceanogr., 12, 256-271.
- [9] Omega Engineering, 1995: The Temperature Handbook. Omega Engineering. [Available online at www.omega.com.] 10. Osborn, 1T.