

MODELING OF SWIPT SYSTEM USING QPSK MODULATION

S. Sudhesi dhevi¹, S. Nandhinisri², S.Anusuya³, AJIN R NAIR⁴

^{1,2,3}Student & Bannari Amman Institute of Technology, Tamilnadu, India

⁴Professor, Dept. of Electronics and communication Engineering, Bannari Amman Institute of Technology, Tamilnadu, India

Abstract - This paper presents a simultaneous wireless information and power transfer system modeling in LabVIEW. Since SWIPT system is very active research topic, a complete system level modeling is indispensable. The LabVIEW based modeling of SWIPT system facilitate the research by providing the system level simulation in an efficient and comprehensive way. Both the SWIPT transmitter and receiver are modeled in LabVIEW environment. The SWIPT transmitter modulates digital data and up-convert to RF carrier frequency at 1 GHz. At SWIPT receiver, RF energy is harvested through RF rectifier in energy harvesting (EH) path. Simultaneously, digital information is recovered through information decoding (ID) path. The QPSK modulation is used for data transfer in SWIPT system. Presented modeling utilizes powerful system design capabilities of LabVIEW which assists in the development and testing of SWIPT system.

Key Words: SWIPT, LabVIEW, QPSK.

1. INTRODUCTION

SWIPT system simultaneously transmits the power and information. In the emerging technology of wireless SWIPT system draws a major attention for the simultaneous power and information transfer. The harvesting of energy from the RF signals which is transmitted forms the basis for SWIPT transmission system. Apart from the energy harvesting path, there is one more path for information decoding.

In swipt system, there is mainly two types of architecture a) Time-swifiting, b) power-splitting. Time switching system gives access to RF signal to the paths in attenuate manner. power splitting architecture is equally splits the signal for the path in the given power splitting ratio. The swipt transmitter and receiver system is designed using QPSK modulation. The power splitting architecture is employed here.

A labview based SWIPT system is designed using qpsk modulation which is obtains the following result;

- A comprehensive system level model of SWIPT transmitter and receiver.
- A flexible and variable input output scheme for checking different results intuitively.
- Employment of QPSK transmitter and receiver system for power and information receiving.

2. LITERATURE SURVEY

Energy harvesting for wireless communication networks is a new paradigm that allows terminals to recharge their batteries from external energy sources in the surrounding environment. A promising energy harvesting technology is wireless power transfer where terminals harvest energy from electromagnetic radiation. Thereby, the energy may be harvested opportunistically from ambient electromagnetic sources or from sources that intentionally transmit electromagnetic energy for energy harvesting purposes. A particularly interesting and challenging scenario arises when sources perform simultaneous wireless information and power transfer (SWIPT), as strong signals not only increase power transfer but also interference. A CAD-oriented design methodology is also proposed, which is aimed at maximizing the overall power conversion efficiency of the harvester through an optimum trade-off among matching losses, power reflection and rectifier efficiency. According to the proposed methodology, a 915-MHz harvester comprising an integrated input matching network and a 17-stage self-compensated rectifier has been designed and fabricated in a 90-nm CMOS technology. The rectifier exhibits a remarkably low input power threshold, as it is able to deliver a 1-V dc output voltage to a capacitive load with a very small input power of 24 dBm (4 W). When driving a 1-M load, the device can supply a 1.2-V output with an input power of 18.8 dBm (13.1 W). The achieved results exceed the performance of previously reported RF multi-stage rectifiers in standard analog CMOS technology. Numerical results show that the optimum location of the relay terminal is closer to the source than to the destination. Moreover, it is demonstrated that the value of the power splitting ratio at the relay significantly impacts the system performance. The results of Monte-Carlo simulations are provided to corroborate the analysis. The parameters such as average bit error rate and end to end signal to noise ratio of the system is analyzed for system performance. Early information theoretical studies on SWIPT have assumed that the same signal can convey both energy and information without losses, revealing a fundamental trade-off between information and power transfer [10]. However, this simultaneous transfer is not possible in practice, as the energy harvesting operation performed in the RF domain destroys the information content. To practically achieve SWIPT, the received signal has to be split in two distinct parts, one for energy harvesting and one for information decoding. SWIPT may provide a promising solution to address this challenge by encouraging the cooperation

between the primary and secondary systems at both the information and energy levels: Transmitters can increase the energy of the information carrying signal to facilitate energy harvesting at the receivers. On the other hand, receivers requiring power transfer may take advantage of the transmitter by falsifying their reported channel state information. Therefore, new QoS concerns regarding communication and energy security naturally arise in SWIPT systems. SWIPT technology has promising applications in several areas that can benefit from ultra-low-power sensing devices. Potential applications include structure monitoring by embedding sensors in buildings, bridges, roads, and so on; healthcare monitoring using implantable bio-medical sensors; and building automation through smart sensors that monitor and control different building processes. However, for successful realization of such SWIPT applications, several challenges must be overcome at various layers from hardware implementation over protocol development to architectural design.

3. SWIPT system with QPSK modulation

3.1 TRANSMISSION OF BINARY DATA STREAMS

The SWIPT system which is designed for transmitter block is shown in the figure 1. The QPSK modulator which consists of odd and even bit extraction, NRZ encoder, adder is designed for the modulation process. The given input binary data stream is modulated using QPSK modulator block.

Binary Data stream and random sequence generator:

Binary data is data whose unit can take on only two possible states, traditionally labeled as 0 and 1 in accordance with the binary numeral system and Boolean algebra. A random sequence generator is a system used to randomly order a range of numbers in a manner that cannot be reasonably predicted better than by random chance. You can use this tool to draw winning numbers for your raffle.

EVEN OR ODD BIT EXTRACTOR:

A parity bit, or check bit, is a bit added to a string of binary code to ensure that the total number of 1-bits in the string is even or odd. Parity bits are used as the simplest form of error detecting code.

NRZ ENCODER:

In telecommunication, a non-return-to-zero (NRZ) line code is a binary code in which ones are represented by one significant condition, usually a positive voltage, while zeros are represented by some other significant condition, usually a negative voltage, with no other neutral or rest condition. The pulses in NRZ have more energy than a return-to-zero (RZ) code, which also has an additional rest state beside the conditions for ones and zeros.

NRZ is not inherently a self-clocking signal, so some additional synchronization technique must be used for avoiding bit slips; examples of such techniques are a run-length-limited constraint and a parallel synchronization signal.

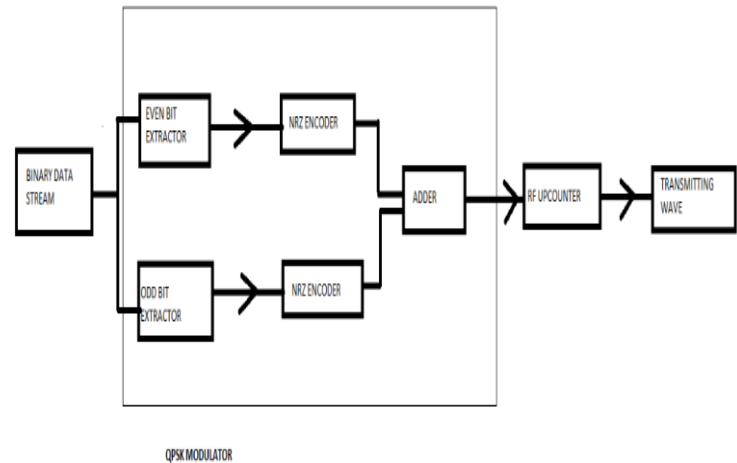

Fig -1: SWIPT transmitter block diagram

QPSK MODULATOR:

The QPSK Modulator uses a bit-splitter, two multipliers with local oscillator, a 2-bit serial to parallel converter, and a summer circuit are separated by the bits splitter and are multiplied with the same carrier to generate odd BPSK (called as PSKI) and even BPSK (called as PSKQ).

3.2 RECEPTION OF SIGNAL WITH CHANNEL NOISE

SWIPT receiver block diagram is presented in Figure 2. RF signal at the receiver is added with channel and circuit noise. After adding the noise, RF signal is forwarded to power splitter. It splits RF signal power for each EH and ID paths based on power splitting ratio. In EH path, RF rectifier and filter block converts RF signal into DC voltage. In parallel, the ID path down converts RF signal to the baseband and recover binary data stream using QPSK demodulation. The RF signal is obtained after applying the adder is upconverted using RF upconverter at a specific carrier frequency, for example 1GHz at this case.

QPSK DEMODULATOR:

QPSK is a digital modulation format that modulates data onto the carrier by changing the phase of the carrier. The data is demodulated by comparing the received signal to the carrier and sampling the phase at a constant rate (symbol rate).

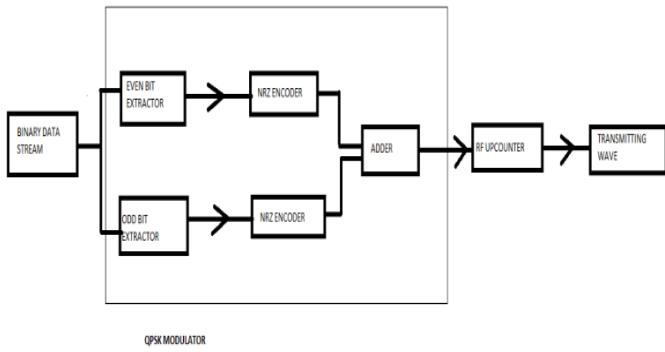

Fig -2: SWIPT receiver block diagram

4. SWIPT system modeling in LabVIEW

LabVIEW simulation model comprises of front panel and block diagram. User input and results are displayed on front panel in LabVIEW. While block diagram in LabVIEW contains graphical code for the SWIPT system. Binary data stream is QPSK modulated according to the symbol rate specified at the front panel. Baseband modulated signal is upconverted to specified carrier frequency. RF signal output power is controlled by specifying RF output power level. At the SWIPT receiver, channel and circuit noise is added with RF signal. Power splitter distributes RF signal power among the energy harvesting path and information decoding path depending on power splitting ratio specified at the front panel. In EH path, RF rectifier and filter converts RF signal into DC voltage. Parameters related to RF rectifier threshold and its efficiency along with filter cut-off frequency are specified through the front panel.

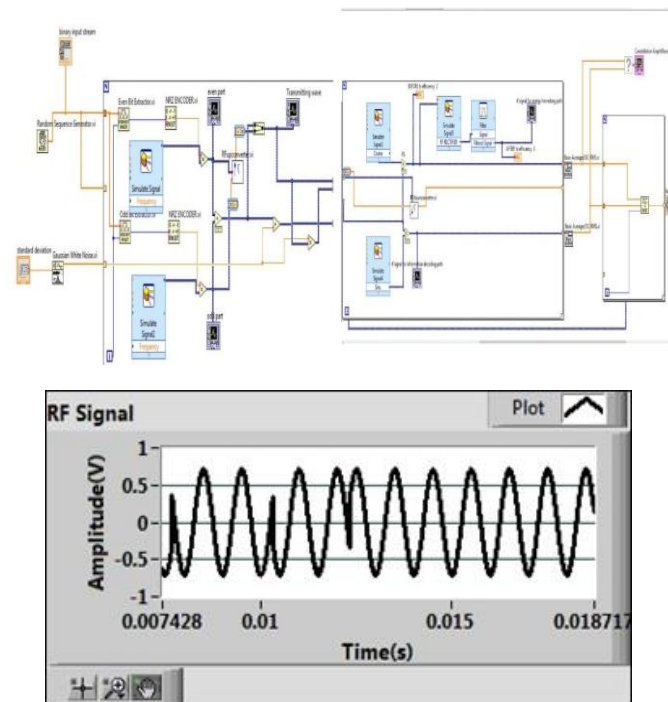
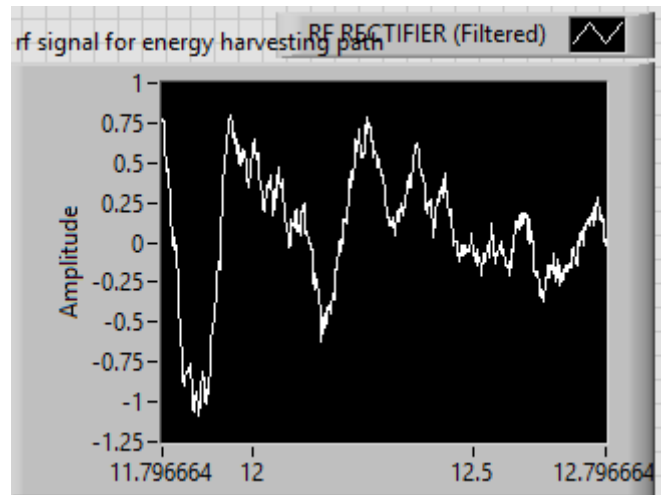
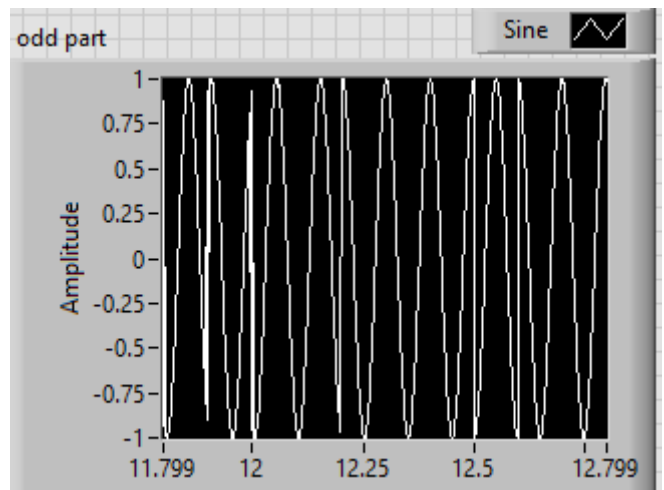
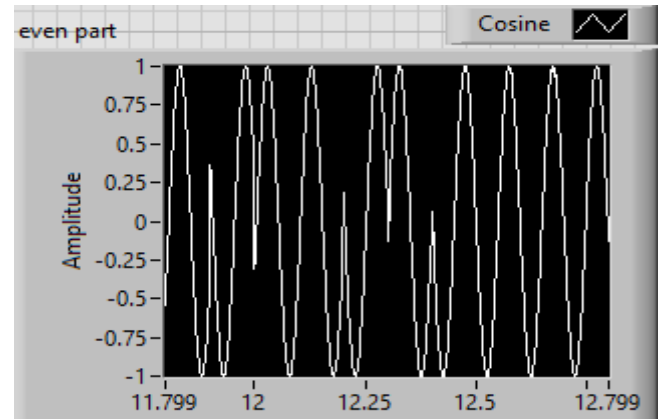
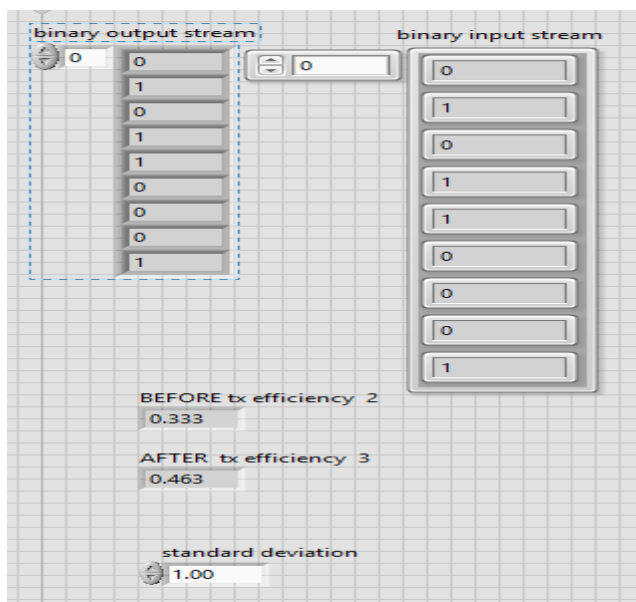
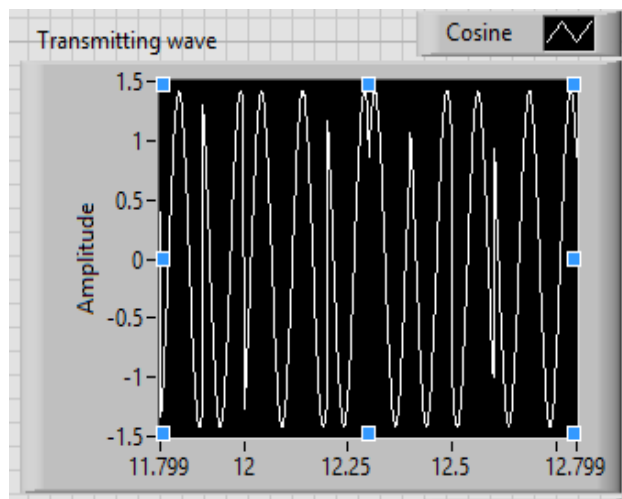
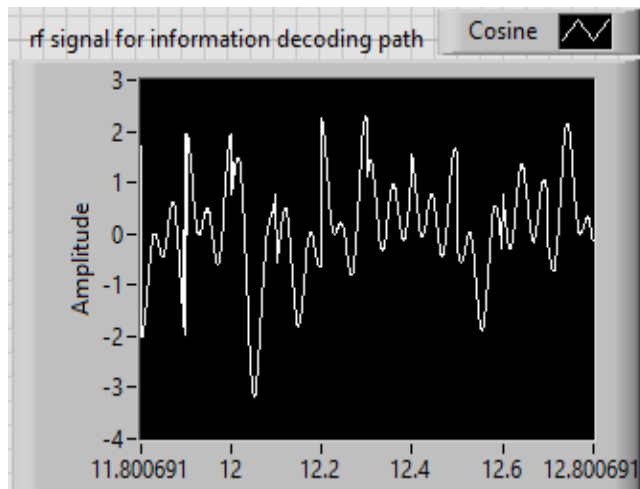

Figure 3. Generated RF signal waveform

4. SIMULATION RESULT

Functionality of SWIPT system modeling is authenticated by performing a simulation of SWIPT system. A QPSK RF signal is generated at 1GHz carrier frequency with an output power selected as 0dBm. Generated RF signal waveform is shown in Figure 6. Power splitting ratio is selected as 0.8 to harvest more energy from RF signal. RF signals provided to both EH and ID paths after power splitting.





Since RF signal power is very limited, RF rectifier having near a zero-volt threshold is required for the SWIPT system. Threshold value of 0.01V along with efficiency of 0.5 for RF rectifier is selected. DC voltage appears at the end of EH path is shown. Binary data stream is successfully demodulated at the receiver and comparison with

transmitted binary data stream is shown. The efficiencies of signal with respect to before and after transmission is analyzed.

5. CONCLUSION

In this paper, LabVIEW based SWIPT system simulation model using QPSK modulation is presented. It can generate RF signals with QPSK modulation for the testing of SWIPT system. Energy harvesting path and information decoding path operate in parallel at SWIPT receiver. Presented simulation model utilizes powerful RF system design capabilities offered by LabVIEW which helps in the SWIPT system design process and testing.

REFERENCES

- [1] A. Roy, A. Klinefelter, F. B. Yahya, X. chen, L. P. Gonzalez-Guerrero, C. J. Lukas, D. A. Kamakshi, J. Boley, K. Craing, M. Faisal, S. Oh, N. E. Roberts, Y. Shakhsher, A. Shrivastava, D. P. Vasudevan, D. D. Wentzloff, and B. H. Calhoun, "A 6.45 μ W self-powered SoC with integrated energy-harvesting power management and ULP asymmetric radios for portable biomedical systems," *IEEE Trans. Biomed. Circuits Syst.*, vol.9, no. 6 pp. 862-874, Dec. 2015.
- [2] T. Le, K. Mayaram, and T. Fiez, "Efficient far-field radio frequency energy harvesting for passively powered sensor networks," *IEEE J. Solid-State Circuits*, vol. 43, no. 5, pp. 1287-1302, May 2008.
- [3] G. Papotto, F. Carrara, and G. Palmisano, "A 90-nm CMOS Threshold-Compensated RF Energy Harvester," *IEEE J. Solid-State Circuits*, vol. 46, no. 9, pp. 1985-1997, Sept. 2011.
- [4] I. Krikidis, S. Timotheou, S. Nikolaou, G. Zheng, D. W. K. Ng and R. Schober, "Simultaneous wireless information and power transfer in modern communication systems," in *IEEE Communications Magazine*, vol. 52, no. 11, pp. 104-110, Nov. 2014
- [5] E. Boshkovska, R. Morsi, D. W. K. Ng and R. Schober, "Power allocation and scheduling for SWIPT systems with non-linear energy harvesting model," 2016 IEEE International Conference on Communications (ICC), Kuala Lumpur, 2016, pp. 1-6.
- [6] H. Liu, K. J. Kim, K. S. Kwak and H. Vincent Poor, "Power Splitting-Based SWIPT With Decode-and-Forward Full-Duplex Relaying," in *IEEE Transactions on Wireless Communications*, vol. 15, no. 11, pp. 7561-7577, Nov. 2016.
- [7] L. Mohjazi, S. Muhaidat and M. Dianati, "Performance Analysis of Differential Modulation in SWIPT Cooperative Networks," in *IEEE Signal Processing Letters*, vol. 23, no. 5, pp. 620-624, May 2016.