

# SOLAR INVERTER USING SUPER CAPACITOR

Prof. Vishal Pimpalkar<sup>1</sup>, Shilpa B. Totade<sup>2</sup>, Rasheena R. Sheikh<sup>3</sup>, Payal R. Amte<sup>4</sup>, Rahul K. Kaithwas<sup>5</sup>, Amol B. Dadmal<sup>6</sup>

<sup>1</sup>Professor of Electrical Engineering Department, Ballarpur Institute of Technology, Ballarpur, India  
<sup>2,3,4,5,6</sup>Student of Electrical Engineering Department, Ballarpur Institute of Technology, Ballarpur, India

\*\*\*

**Abstract-** Nowadays the availability of non renewable sources are decreasing so we can use the renewable sources in the form of sunlight. The requirement of electrical energy is increasing day by day that is the reason we can create the module, "Solar Inverter Using Super Capacitor".

A Solar inverter is a type of electrical converter which converts the variable direct current (DC) output of PV solar panel into a utility frequency alternating current (AC) that can be used to fulfill many domestic purpose.

Also we use here a new technology, the super capacitor has emerged with the potential to enable major advance in energy storage. Super capacitors are governed by the same fundamental equation as conventional capacitor, but can achieve greater capacitor value due to its large surface area of electrode and thinner dielectric, hence it act as a battery which can stores large amount of charges.

**Key words-** Solar panel, Charger circuit, Super capacitor, Battery, Step up transformer

## 1. INTRODUCTION

The project aim is developing a solar inverter, which help common people to control device like bulb, fan, water pump and other load.

In this project we use a solar plate by which we are generating electricity. This obtained energy which has to store in battery as well as in super capacitor .a solar inverter which converts the direct current into alternating current. Hence we need to store and release large amount of electricity very quickly hence we use super capacitor.

Super capacitor also called as ultra capacitor and electric double layer capacitor (EDLC) are capacitor with capacitance value greater than any other capacitor type available today. Capacitance values reaching up to 800 farads in a single standard case size are available. And the super capacitor that it has sufficient energy for peak power requirement in a short period of time and a battery is able to store more energy and supply to the load continues power at a nominal rate over a longer period of time. This combination is ideal and highly recommended to be used in rural areas because of the reduced maintenance cost by extremely battery performance and life time.

## 2. PROPOSED WORKED

In this project we are making a single phase PWM inverter. Firstly the output of solar PV cells are corner to both super capacitor and battery via charging circuit, then this supply is fed to the inverter circuit with the help of toggle switch. The supply of only one source is fed to the inverter circuit at a time. The ICS4324 is a PWM IC which gives a PWM which amplified with the help of transistor.

The output of transistor is given to the MOSFET which converts PWM signals into a staircase waves and the impurities are filtered with the help of LC filter connected between MOSFET's and transformer then pure sine wave is fed to the 1phase step up transformer which steps up the 12V supply to 230V utilisation level and then this supply is used to sum of loads.

## 3. BLOCK DIAGRAM AND COMPONENT DETAIL

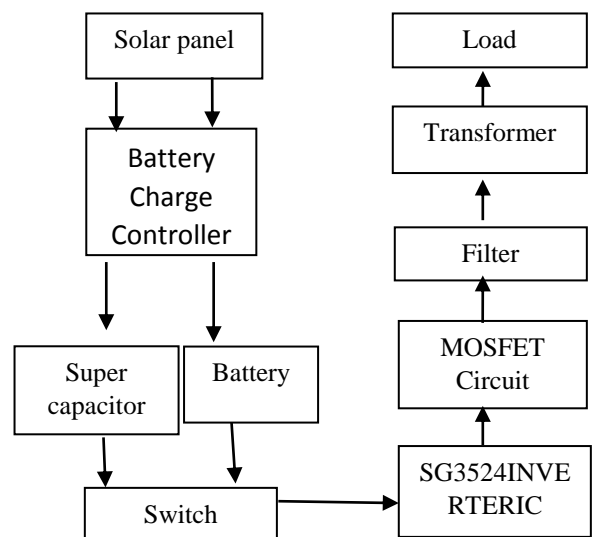

Fig-3 Block Diagram of Solar Inverter Using Super Capacitor

**3.1-Solar Panel:** Photovoltaic solar panels absorb sunlight as a source of energy, to generate direct current electricity. A photovoltaic (PV) module is a packaged, connected assembly of photovoltaic solar cells available in different voltages. Photovoltaic modules constitute the photovoltaic system that generates and supplies solar electricity in commercial and residential application.



Fig-3.1 Solar Panel

**3.2-Super Capacitor:** Super capacitors are also called as ultra capacitors and electric double layer capacitor type available today. Capacitance values reaching up to 800 Farads in a single standard case size are available. Super capacitors can be charged and discharged quickly while batteries can supply the bulk energy since they can store and deliver larger amount of energy over a longer slower period of time.



Fig-3.2 Super capacitor

**3.3-Rechargeable Battery:** A rechargeable battery, storage battery, secondary cell, or accumulator is a type of electrical battery which can be charged, discharged into a load, and recharge many times, as opposed to a disposable or primary battery, which is supplied fully charged and discharged after use. It is composed of one or more electrochemical cells.



Fig-3.3 Rechargeable Battery

**3.4-Solar Inverter:** A solar inverter is similar to a normal electric inverter but uses the energy of the sun. A solar inverter helps in converting the direct current with the help of solar power. Solar inverter is also called as photovoltaic solar inverter. These devices can help you to save lots of money. The small scale grid one have just two components and inverter while the off grid system are complicated and consist of batteries which allows users to use appliances during the night when there is no sunlight available.

It has solar inverter main components are as follows:

1. IC - SG3524 (8V, 500mA)
2. LM7808 (8V, 1.5 A)
3. MOSFET (IRFZ44N) 115V, 40A
4. Potentiometer (2.2 K)
5. Capacitor (0.1µf, 220µf, 47µf, 1µf,4700µf)

6. Transistor (BC547, BC557)
7. Resistor (3.9Ω , 1kΩ, 10kΩ, 100kΩ, 2.2kΩ, 47kΩ, 4.7kΩ)
8. Diode (1N4007 ) 5A
9. LED 5 mm , 3.5 V, 500mA

**IC SG3524:** Complete Pulse-Width Modulation (PWM) Power-Control Circuitry.



Fig-3.4 IC SG3524

**3.5 -On/Off Switch:** On/Off control for loads

**Toggle switch:** This switch gets its name from the fact that you flip a lever to turn it on and flip it back to turn it off.



Fig-3.5 On/Off Switch

**3.6-Step up transformer:**

A transformer is static electrical equipment which transforms electrical energy to the magnetic energy and again to the electrical energy. Essentially, that is the main task of the transformer, converting from the low voltage and high current on the primary side to high voltage and low current on the secondary side and vice versa.



Fig3.6 Step up transformer

#### 4. CONNECTION DIAGRAM

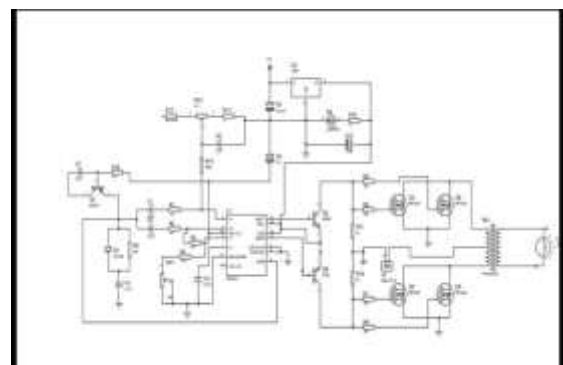

Fig-4Connection Diagram

#### 4.2 ADVANTAGE

- It has long life.
- It works for large number of cycle without wear and aging.
- Rapid charging: - It takes seconds to charge completely.
- Low cost: - It is less expensive compared to electrochemical battery.
- High power storage.

#### 5. CONCLUSION

This project concluded a design of "Solar based inverter" such that inverter was designed and from solar plate generates solar energy and utilizing this energy for load. Based upon the review of the literature described above, it seems unlikely that super capacitor s will be replace batteries as the general solution for power storage. This is primary because envisioned super capacitor systems do not store as much energy as batteries.

Thus, super capacitor s may emerge as the solution for many application specific power systems. Especially, there has been great interest in developing super capacitor s for electric vehicle hybrid power systems, pulse power applications, as well as back-up and emergency power supplies.

#### REFERENCES

- [1] W. J. Chiang, H. L. Jou, and J.C. Wu, "Maximum power point tracking method for the voltage-mode grid-connected inverter of photovoltaic generation system," in 2008 IEEE International Conference on Sustainable Energy Technologies, Nov 2008, pp. 1-6.
- [2] Smith, T. A., Mars, J. P., & Turner, G. A. (2002). "Using super to improve battery performance." IEEE 33<sup>rd</sup> Annual IEEE Power Electronics Specialists Conference. 2002
- [3] S. Liu, R. E. White and R. A. Dougal, "Power and Life Extension of Battery-Ultra capacitor Hybrids," IEEE Transactions on Components and Packaging Technologies, vol. 25, no. 1, pp. 120-131, 2002.
- [4] S. Vazquez, S. M. Lukic, E. Galvan, L. G. Franquelo and J. M. Carrasco, "Energy Storage Systems for Transport and Grid Applications," IEEE Transactions on Industrial Electronics, vol. 57, no. 12, pp. 3881-3895, 2010.
- [5] M. I. Fahmi Rajprasad Kumar Raj Kumar, Roselina Arelhi, Dino Isa "Study on the Effect of Super capacitors in Solar PV System for Rural Application in Malaysia" 978-1-4673-9682-0/15 2015 IEEE
- [6] Wang, G.; Ciobotaru, M.; Agelidis, V. Power Smoothing of Large Solar PV Plant Using Hybrid Energy Storage. IEEE Trans. Sustain. Energy 2014, 5, 834-842.
- [7] Glavin, M.; Hurley, W. Optimisation of a photovoltaic battery ultra capacitor hybrid energy storage system .Sol. Energy 2012, 86, 3009-3020.
- [8] Lahyani, A.; Venet, P.; Guermazi, A.; Troudi, A. Battery/Super capacitors Combination in Uninterruptible Power Supply (UPS). IEEE Trans. Power Electr. 2013, 28, 1509-1522.
- [9] Gao, L.; Dougal, R.; Liu, S. Power enhancement of an actively controlled battery/ultra capacitor hybrid. IEEE Trans. Power Elect. 2005, 20, 236-243.
- [10] Choi, M.; Kim, S.; Seo, S. Energy Management Optimization in a Battery/Super capacitor Hybrid Energy Storage System. IEEE Trans. Smart Grid 2012, 3, 463-472.