

# DESIGN AND TEST 3D PRINTED LATTICE STRUCTURE FOR UAV

Prof. Shital Patel<sup>1</sup>, Akash Bhoi<sup>2</sup>, Vivek Maurya<sup>3</sup>, Akash Wankhede<sup>4</sup>, Rajat Bakshi<sup>5</sup>

<sup>1</sup>Prof. Shital V. Patel, Dept. Mechanical Engineering, Bharati vidyapeeth college of engineering, Navi Mumbai, Maharashtra, India

<sup>2-5</sup> Dept. Mechanical Engineering, Bharati vidyapeeth college of engineering, Navi Mumbai, Maharashtra, India

\*\*\*

**Abstract** - The objective of this study is to analyze different lattice structures and select the structure with optimum load and deflection characteristics. The study examines three lattice structures – honeycomb structure, 3-D kagome structure and 3-D pyramid structure of different thickness spanning from 1 mm to 2mm with 0.2 mm step and manufactured using FDM process on Accucraft 3-D printer with rectangular cross-section of sample size 20\*20\*100 mm. The material used for 3-D printing is Acrylonitrile butadiene styrene (ABS). Static structural analysis is performed on SOLIDWORKS to study deflection of the structures. As the demand for UAV have increased exponentially in Military, Surveillance, agriculture and many other commercial applications, it becomes important to reduce its weight to enhance the efficiency by lowering the power requirement and allows to increase its payload capacity while retaining or even enhancing its structural strength.

**Key Words:** UAV, 3-D printing, Lattice Structure, 3D Kagome, 3D Pyramid, 3D honeycomb

## 1.INTRODUCTION

UAV's are widely used for various applications ranging from civilian to military purposes. However, their use has been constrained due to their poor flight time and poor payload. Hence the need arises to develop lightweight UAV's with inclusions of the above-mentioned lattice designs. The light weight UAV will have high endurance, higher payload carrying capacity, low manufacturing cost, strong adaptability and higher strength-to-weight ratio. The paper aims to develop a light weight UAV structure by incorporating 3d kagome, 3d pyramid and hexagonal lattice structure to find the optimal structure. This will be achieved by comparing these lattice structures by analyzing their load characteristics in bending. The load characteristics are flexural strength and flexural strain.

### 1.1 3-D printed lattice structure

The weight of the solid structures can be reduced by reducing the material to yield 3D kagome, 3D

pyramid or 3D honeycomb like interior structures. These structures provide optimal strength-to-weight ratio and relieves stress.

UAV structure must withstand the aerodynamic forces generated from rotors and the gravitational force due to its self-weight and mounted weights. The arm of the quad copter acts as a cantilever beam with end loading and the material behaves as  $\sigma = \epsilon E$  (Hooke's law)

3 lattice structures are considered for this research. Namely Kagome, Honeycomb, Pyramid Structures.

### 3D Kagome structure

**Fig-1:** Unit cell of 3D Kagome structure

Based on its elastic modulus 3D kagome is considered as an optimal structure for optimization since its origin as a pattern in bamboo baskets.

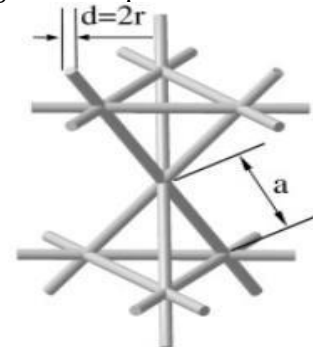

Compared to pyramidal and tetrahedral unit cell properties 3D kagome was observed to have superior properties. Also 3D Kagome is less susceptible to plastic buckling under compression. It has demonstrated greater load capacity and is isotropic in shear. A pair of tetrahedrons are rotationally offset by 60° from each other. When conducted a standard compression test on 3D Kagome, 3D pyramid and hexagonal structure. The results demonstrated that 3D Kagome sustained highest compression stress than other structures.

### 3-D Pyramid Structure



Fig-2: 3D pyramid structure

The unit cell of pyramid structure consists of four inclined trusses connected to a single node. The angle of inclination of four trusses can be altered as per the requirement of the structure. This variation in four trusses makes the structure strong to sustain compressive and shear stress radically. As per the standard compression test conducted on 3D pyramid showed that it was not able to withstand much compression stress as compared to 3D Kagome structure.

### 3D Honeycomb Structure

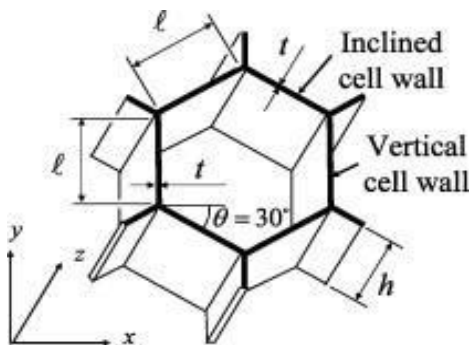

Fig-3: Honeycomb Structure

Hexagonal cell consists of six cell walls connected with each other at a 60° angle. The cell configuration can be altered depending upon the required application. Honeycomb structures are anisotropic (directional properties) in nature. This helps to change the cell direction as per the required application in the structure. The compressive strength, crush strength, shear strength and compressive modulus are the most vital strength properties associated with honeycomb cell.

### Existing Methodology

The methods to analyze optimal structure through topology optimization, geometry optimization and insertion of lattice structures are carried out using simulation (ANSYS, Abaqus or MATLAB) and also through testing the structure in a universal testing machine for compression and tension under bending.

## 2. METHODOLOGY

### Stage 1: Analyze load characteristics on frame

UAV structure must withstand the aerodynamic forces generated from rotors and the gravitational force due to its self-weight and mounted weights. It undergoes sudden impact and reverse torque during its flight time. The deformation of the frame is associated with cross-sectional shape of the structure under bending. During its flight, the thrust generated from propeller will result in torsional stiffness. This results in generation of tensile and compressive stresses on the frame structure. Now considering the forces acting on the frame a suitable structure will be designed. Based on DJI MATRICE 100 the frame of the quadcopter will be designed. Instead of circular cross-section as in existing MATRICE 100, the frame will be of rectangular cross-section. The propulsion systems will also be same as MATRICE 100 with maximum take-off weight of 3600 g.

### Stage 2: Design a Lattice structure

The design of the lattice truss is carried out using SOLIDWORKS. Based on the DJI MATRICE 100 frame structure, the lattice structures will be of rectangular instead of circular cross-section. The rectangular cross-section is of 20mm\*20mm\*100mm frame with different lattice structures incorporated into it. The lattice structures are 3D Kagome, 3D pyramid and honeycomb structure. The thickness of the truss lattice varies in a range of 1 mm to 2 mm with 0.2 mm step.

### Honeycomb Structure

The honeycomb lattice is designed with each side of 2 mm and 60° angles between each sides of the hexagon. The thickness between each hexagon ranges from 1.2 mm to 2 mm with 0.2 mm step. The vertical distance between the two hexagons is half the thickness between the two sides of adjacent hexagon.

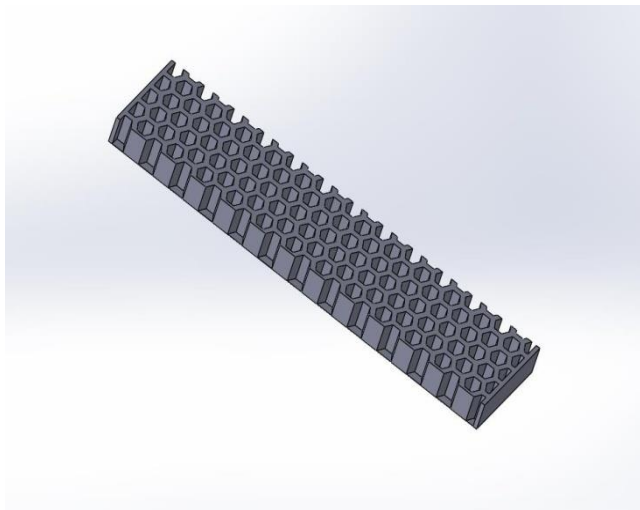

**Fig-3:** Sectional view of Honeycomb structure

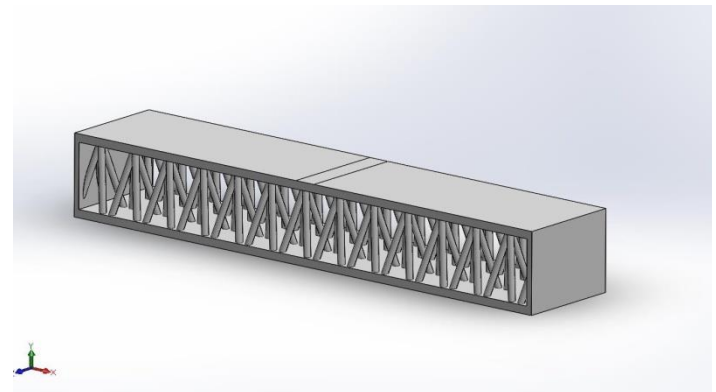

**Fig-5:** CAD model of Pyramid

### Stage 3: Simulation

The simulation of the structure is carried out on SOLIDWORKS simulation module. The material assigned is Acrylonitrile butadiene styrene (ABS). The structure will be under compressive and tensile stress due to upward and downward acting forces. To study the load characteristics, 3-point bending test conditions are applied to the lattice structure. Boundary conditions are applied at two points on the bottom face with a span length of 70 mm and load of 15N (thrust load).

### Kagome Structure

The Kagome structure is set of trusses consisting of a pair of tetrahedrons vertically inverted. The angle between each truss is set at  $60^{\circ}$ . One-unit truss lattice of Kagome consist of 6 struts. The thickness of each truss varies from 1 mm to 2 mm with step of 0.2 mm.

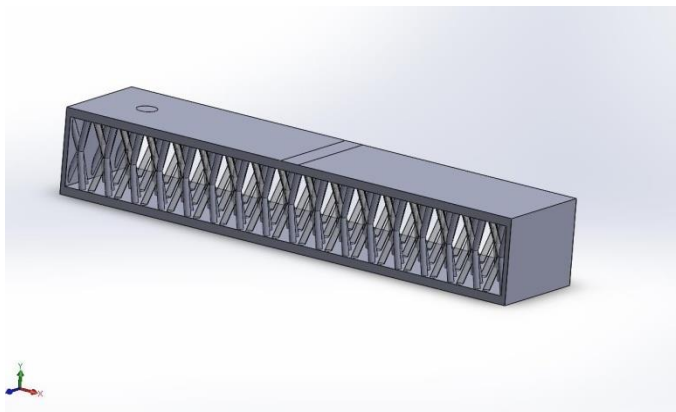

**Fig-4:** 3D CAD model of Kagome structure

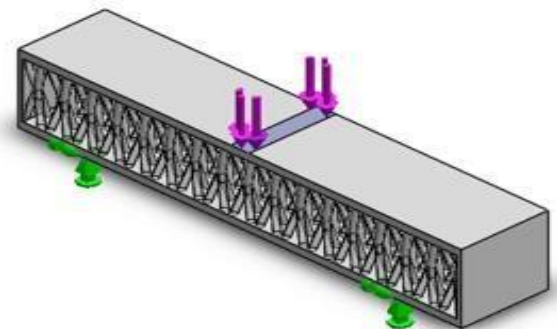

**Fig-6:** Loads and Fixtures for Kagome lattice structure

### Pyramid Structure

The pyramid structure consists of 4 trusses set at an angle of  $90^{\circ}$  from each other. All trusses originate from a common point and diverge to form a rectangle. Similar to Kagome truss, the thickness of the pyramid truss varies from 1.0 mm to 2.0 mm with 0.2 mm steps

### 3. RESULTS

SIMULATION DISPLACEMENT RESULTS (mm) AT 15N LOAD			
Lattice truss thickness (mm)	Honeycomb	Kagome	Pyramid
1		0.125	0.1811
1.2	0.109	0.0949	0.136
1.4	0.102	0.0712	0.099
1.6	0.093	0.0538	0.077
1.8	0.056	0.046	0.0618
2	0.054	0.0394	0.0487

Table -1: Simulation results for displacement

The lattice structures were simulated under same boundary conditions and load. The results generated from simulation The trend for deflection of the lattice structures in shown in table 2

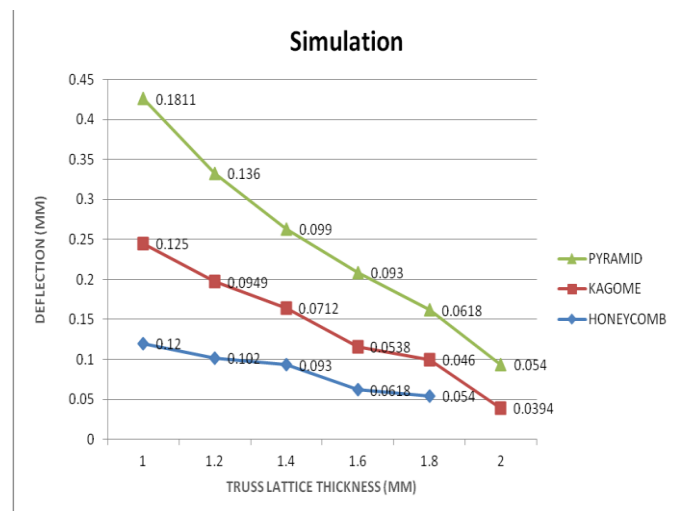

Table -2: Deflection of all the lattice structures

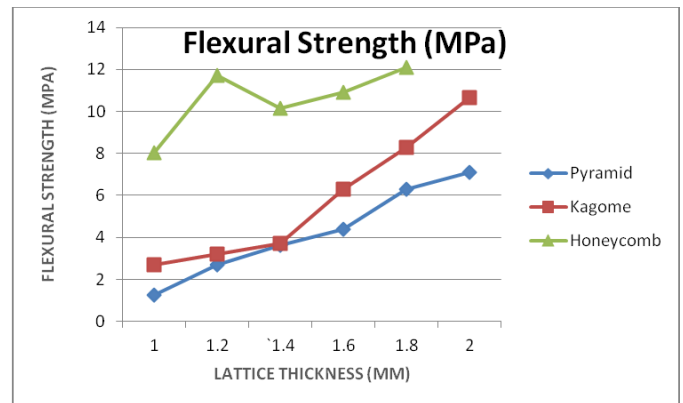

Table -3: Deflection of all the lattice structure

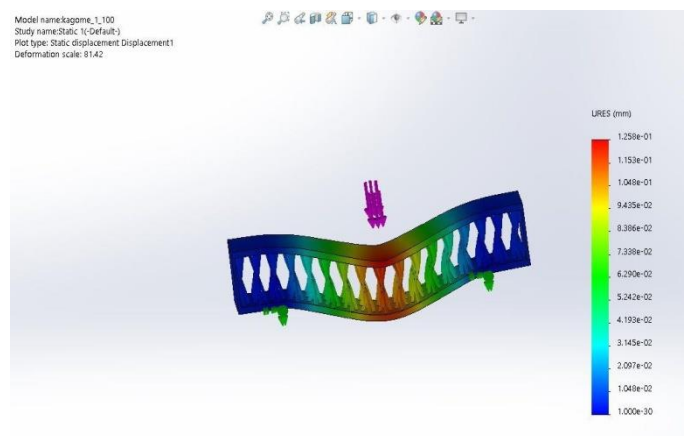

Fig-7: Displacement result for Kagome structure with 1.2 mm thickness

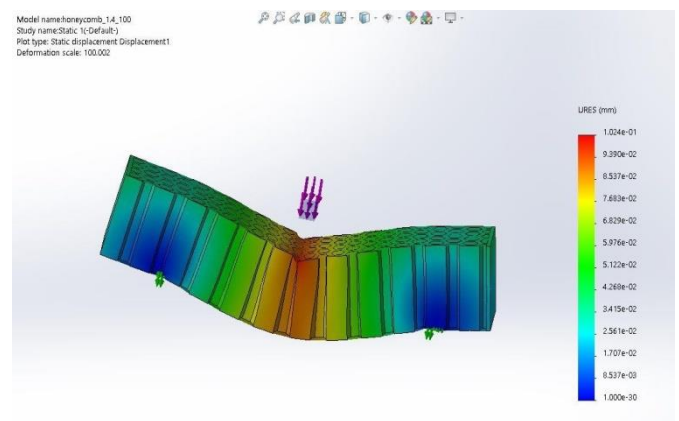

Fig-8: Displacement result for Honeycomb structure with 1 mm thickness

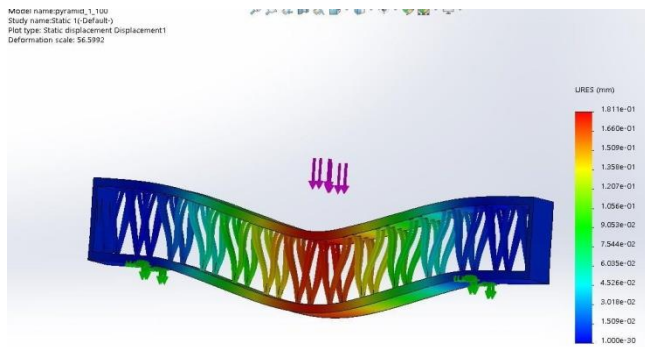

Fig-9: Displacement result for pyramid structure

### 3. CONCLUSIONS

In this research project, the Kagome, pyramid and honeycomb lattice structures were investigated with using compliant mechanism. The purpose of the study was to identify the optimal lattice structure with optimal flexural strength and flexural strain. The lattice structures with varying thickness were designed on SOLIDWORKS. These structures were simulated under 3-point bend test conditions with thrust load of 15N on SOLIDWORKS automatic simulation module. Using FDM technology the lattice structures were manufactured Kagome lattice exhibited highest strength-to- weight ratio of 54.07 N/grams with 4.3 mm extension at break.

Lattice structure	Thickness (mm)	Optimal		
		Maximum load (N)	Deflection (mm)	Weight (grams)
Honeycomb	1.2	612.12	2.5	20.41
Kagome	1.2	243.18	3.13	11.21
	1.4	283.41	2.589	12.03
	1.6	479.02	3.4	12.94
	1.8	630.69	3.51	13.94
Pyramid	1.4	275.243	3.17	11.16
	1.6	333.31	2.57	11.84
	2	539.09	3.58	13.42

### REFERENCES

[1] T. D. Ngo, A. Kashani, G. Imbalzano, K. T. Q. Nguyen, and D. Hui, "Additive manufacturing (3D printing): A review of materials, methods, applications and challenges," *Composites Part B: Engineering*, vol. 143, pp. 172-196, 2018.

[2] H. Crapo and W. Whiteley, "The geometry of rigid structures," *Encyclopedia of Mathematics and its Applications*, 1989.

[3] R. T. Haftka and R. V. Grandhi, "Structural shape optimization—a survey," *Computer methods in applied mechanics and engineering*, vol. 57, no. 1, pp. 91-106, 1986.

[4] J. Kindinger, "Lightweight structural cores," *ASM Handbook*, vol. 21, pp. 180-183, 2001.

[5] T. Bitzer, *Honeycomb technology: materials, design, manufacturing, applications and testing*. Springer Science & Business Media, 2012.

[6] W. Wang *et al.*, "Cost-effective printing of 3D objects with skin-frame structures," *ACM Transactions on Graphics*, vol. 32, no. 6, pp. 1-10, 2013.

[7] L. Lu *et al.*, "Build-to-last," *ACM Transactions on Graphics*, vol. 33, no. 4, pp. 1-10, 2014.

[8] S. K. Moon, Y. E. Tan, J. Hwang, and Y.-J. Yoon, "Application of 3D printing technology for designing light-weight unmanned aerial vehicle wing structures," *International Journal of Precision Engineering and Manufacturing-Green Technology*, vol. 1, no. 3, pp. 223-228, 2015.

[9] J. Wang, A. G. Evans, K. Dharmasena, and H. N. G. Wadley, "On the performance of truss panels with Kagomé cores," *International Journal of Solids and Structures*, vol. 40, no. 25, pp. 6981-6988, 2003.

[10] C. Ferro, R. Grassi, C. Seclì, and P. Maggiore, "Additive Manufacturing Offers New Opportunities in UAV Research," *Procedia CIRP*, vol. 41, pp. 1004-1010, 2016.

[11] T. Belendez, C. Neipp, and A. Belendez, "Large and small deflections of a cantilever beam,"

[12] *EUROPEAN JOURNAL OF PHYSICS*, vol. 23, no. 2002, p. 10, 8 May 2002 2002.

- [13] S. Liu, Q. Li, J. Liu, W. Chen, and Y. Zhang, "A Realization Method for Transforming a Topology Optimization Design into Additive Manufacturing Structures," *Engineering*, 2018.
- [14] M. Zhou and G. Rozvany, "The COC algorithm, Part II: topological, geometrical and generalized shape optimization," *Computer Methods in Applied Mechanics and Engineering*, vol. 89, no. 1-3, pp. 309-336, 1991.
- [15] I. A. D. Brackett, R. Hague, "TOPOLOGY OPTIMIZATION FOR ADDITIVE MANUFACTURING," *Wolfson School of Mechanical and Manufacturing Engineering, Loughborough University, Loughborough, Leicestershire* 2011.
- [16] O. Stava, J. Vanek, B. Benes, N. Carr, and R. Měch, "Stress relief," *ACM Transactions on Graphics*, vol. 31, no. 4, pp. 1-11, 2012.
- [17] Y.-H. Lee, B.-K. Lee, I. Jeon, and K.-J. Kang, "Wire-woven bulk Kagome truss cores," *Acta Materialia*, vol. 55, no. 18, pp. 6084-6094, 2007/10/01/ 2007.
- [18] M. J. A. M. Walters, "Designing and analysing Kagome structures for crash safety applications," Masters, Department of Mechanical Engineering, Eindhoven University of Technology, Eindhoven, MT 05.17, 2005.
- [19] S. Hyun, A. M. Karlsson, S. Torquato, and A. G. Evans, "Simulated properties of Kagomé and tetragonal truss core panels," *International Journal of Solids and Structures*, vol. 40, no. 25, pp. 6989-6998, 2003/12/01/ 2003.
- [20] D. H. Chen, "Bending deformation of honeycomb consisting of regular hexagonal cells."
- [21] *Composite Structures*, vol. 93, no. 2, pp. 736-746, 2011/01/01/ 2011.
- [22] M. Kuczewicz, P. Baranowski, J. Małachowski, A. Popławski, and P. Płatek, "Modelling, and characterization of 3D printed cellular structures," *Materials & Design*, vol. 142, pp. 177-189, 2018.