

DESIGN OF ROTATING WHEEL FOR DIP TEST OF POLYMERIC INSULATORS

Ashwini A V¹, Ravi K N², Ramya M³, Divya N S⁴

¹⁻⁴Sapthagiri College of Engineering, Bengaluru

^{1,3,4}Asst. Professor, ²HoD & Professor Dept. of Electrical and Electronics Engineering, Sapthagiri college of Engineering, Karnataka, India

Abstract - Ageing of polymeric is the present problem being addressed by the research workers. 1000 hours test and 5000 hours test have been proposed in the standards, as an additional test Rotating wheel test has been suggested by the standard for accessing the Aging property of the polymers. The rotating wheel test presently available in labs are of a very high cost which is not affordable hence a designing of rotating wheel set up is been done so that it can be used in domestic purposes. To design the rotating wheel for Rotating-Wheel Dip Test (RWDT) of the polymeric insulators. The design of rotating wheel plays an important part for RWDT which is done properly to have the stability of holding the rods and the samples in stable condition and to hold on for the dip test without any disruption.

To run the stepper motor according to specified time by programming. The specific time delay is given for the test to be performed and the test is carried out by the steps given by the program. Each step has the instruction of specific time delay where the sample has to hold it for a specified time.

Key Words: polymer, Rotating Wheel Dip Test (RWDT), Aging.

1. INTRODUCTION

Generally, insulators are made up of porcelain and glass, which are extensively used in power transmission and distribution systems, which are generally termed as ceramic. These ceramic insulators can be used either for tensile force or compressive force. They have a longer life of more than 110 years. These ceramic insulators have many disadvantages despite having a longer life. The major disadvantages of these insulators are its weight and do not perform well in certain ambient pollution conditions. Additional problem is that they are non-sustainable to vandalism. Since every country is choosing industrialization, there is an increase in ambient pollution, which causes pollution flashover on the surface of a ceramic insulator due to non-linearity of surface length with increased transmission voltages (The surface length of a ceramic insulator is decided based on the air gap performance of the over voltages for the given system). In the present world, countries opt EHV/UHV transmission but ceramic insulator does not hold good for transmission system with voltage greater than 220kV under medium and heavy pollution. Due

to these disadvantages, researchers worked on an alternate material for insulation and as a result of this "polymeric insulator" emerged during the sixties which is having good advantages over ceramic insulators. Although polymeric insulator has a lot of pros, it faces the problem of ageing and due to this, they are bound to yield over a period. The pollution level of environment and the service voltage determines the degree of ageing of the composite insulators. There is a change in the chemical composition of polymeric insulators due to the long term exposure of polymer surfaces to the influence of environmental, mechanical and electrical stresses and pollution which results in loss of its electrical properties like surface resistance, hydrophobicity, which causes surface erosion. The main reason for surface erosion is dry band arcing over the surface of the insulator, which occurs due to the conduction between water globules on the surface of the polymeric insulator. Initially, the standard of ageing test for polymeric insulator was about 1000hours. Later on, the same standard was changed to 5000 hours due to the continuous application of both voltage and salt fog. The test included all the combination of UV, humidity, rain and salt fog cyclically on the continuous application of voltage. Presently this has been taken off and there are no ageing tests in standards. Tracking wheel test has been introduced newly instead of this new ageing test which has to be evolved considering some of the important factors.

2. Experiments on Polymeric Material Using Rotating Wheel

Rotating Wheel Dip Test is better than the other two tests because it is suitable to examine the hydrophobicity resistance of polymeric samples. In this paper, along with the polymeric insulator samples, RWDT is conducted for the fiber plates which acts as the rigid support for the samples [3]. A decrease of hydrophobicity was reduced on the tested surface, with a higher loss of hydrophobicity on the conventional surface [4]. By RWDT method a greater number of insulator samples can be tested one at a time. As compared to other test RWDT require less time Leakage current measured is high in RWDT compared to salt fog test after ageing [1]. The results of the RWDT show a good correlation to the results of ageing under service condition [2].

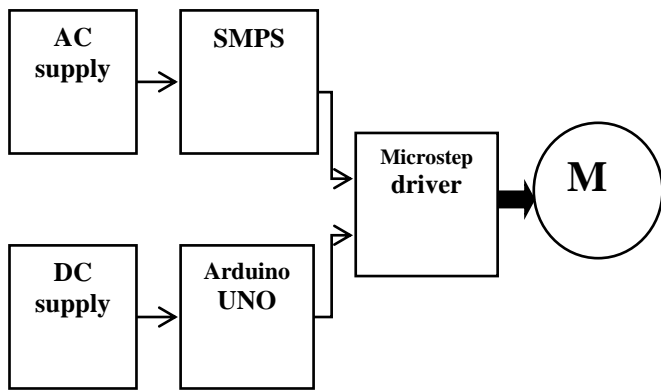


Figure 1: Block diagram of the setup

2.1 Working Principle

The power supply of 230V, single phase is given to SMPS. From the SMPS a DC supply is given to the stepper motor drive (micro-step driver) which is used to drive the stepper motor. Without this drive, the motor is unable to run. According to IEC 62217 standards, the motor is made to run in such a way that, after 10 seconds one out of four sample insulators get dipped in the saline water and remains in saline water for 40 seconds. Similarly, all four samples will be in four positions for 40 seconds at a time. Therefore, it takes 200 seconds to complete one cycle i.e., one rotation. To run the wheel connected to the motor according to the above-mentioned time specifications, microcontroller (Arduino UNO) is being used. This is programmed using Arduino IDE software.

A brief explanation of the components used are as follows:

- 1) Power supply: It is an electrical device that supplies electric power to an electrical load. Here Switching Mode Power Supply (SMPS) is used. It is an electric power supply unit (PSU) which includes a switching regulator acts as an internal control circuit that switches the load current rapidly ON and OFF to stabilize the output voltage. It is used as a replacement for linear regulators.
- 2) Micro-controller: It is a compact IC designed to govern a specific operation in an embedded system. A typical microcontroller includes a processor, memory and input/output ports on a single peripheral chip. The micro-controller used here is Arduino UNO.
- 3) Electric Drive: An electric drive is defined as a form of machine equipment designed to convert electrical energy into mechanical energy and provide electrical control of the processes. It is used for controlling the motion of an electrical machine. Electric drive used here is the micro-step driver to drive the stepper motor.
- 4) Stepper Motor: A Stepper Motor or step motor is a brushless DC electric motor that divides a full rotation into many equal steps. It is an electromagnetic device that converts digital pulses into mechanical shaft rotation. The main advantages are low cost, high reliability, high torque at

low speeds and simple, rugged construction that operates in almost any environment.

2.2 Methodology

Rotating Wheel Dip Test (RWDT) performs ageing which represents the effect of polymeric insulator samples under stressful condition. The rotating wheel setup has been designed concerning the standard setup. The main purpose to redesign the setup is to analysis the samples at a lesser budget and to test in laboratory conditions. The main purpose of this is to monitor the early ageing period. The test is terminated after any tracking has occurred (dry banding) [5] on the sample.

2.3 Construction

The test setup consists of four samples of polymeric insulators fixed on the rotating wheel. Each polymeric insulator samples are placed on a rigid fiber material, which is also tested along with the polymeric insulator sample. This fiber holds the polymeric insulator samples firmly giving steady support. Rotating wheel consists of four rods which are exactly placed 90 degrees apart from each other. The two specimens (polymeric insulator and fiber) are clamped to an insulating material (fiber) and is fixed to a rod which is attached to a rotating wheel. This wheel is attached to the shaft of the motor (stepper motor). The material used for the rotating wheel is a lightweight metal, this is to reduce the weight on the motor shaft and to prevent it from damage (bending of the shaft).

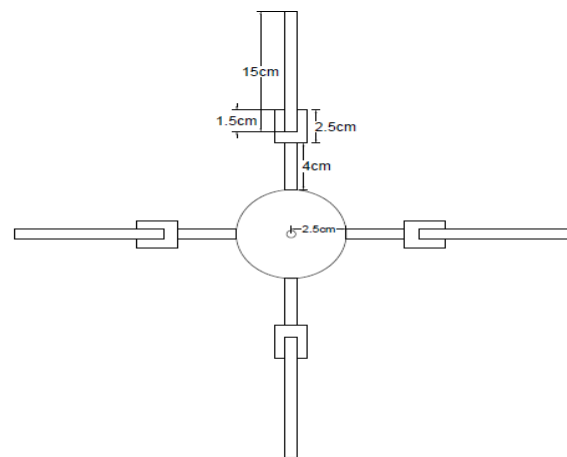


Fig2: Representation of dimensions of the wheel setup

The four positions of RWDT are:

- 1) The 1st position is the immersion in saline water.
- 2) The 2nd is a horizontal de-wetting position allowing the water to drip off as a consequence of hydrophobicity.

- 3) The 3rd is an energized position in which the sample is supplied a high voltage from the upper end and peak leakage current is recorded by a current recorder.
- 4) At the 4th position, the sample rests at horizontal position

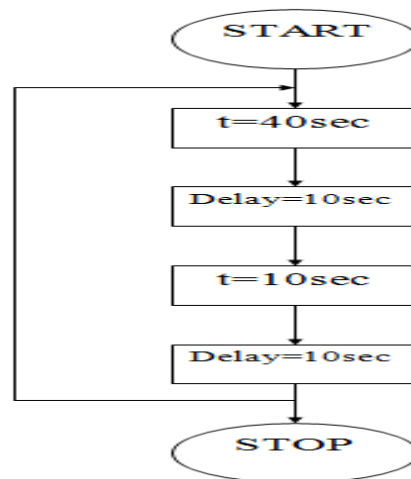
Schematic representation of a rotating wheel setup is as shown in figure 1. It consists of Four Positions of Rotating wheel:

1. Dipping
2. Dripping
3. Energizing
4. Cooling

Now the wheel is made to run according to the specific time specifications by varying pulses given to the motor. In most of the RWDTs carried out by the researchers, the polymeric samples take 8 seconds to move from one position to another and take 40 seconds to be in one position. Therefore it takes 192 seconds for one complete revolution. One out of four samples after dipping in saline water moves to another position and stays there for 40 seconds. But the water drips off from the surface of polymeric samples within 20-25 seconds. Because of which we can say that the stationary time for the horizontal position is more.

In this Experiment, the wheel is made to move from one position to another in 10 seconds. The stationary time for the vertical positions of polymeric samples i.e., position 1 and 3 is 40 seconds. While the stationary time for the horizontal positions of the polymeric samples i.e., position 2 and 4 is 10 seconds. The time taken for one complete revolution in 140 seconds. From this time specification, the stationary time for the horizontal position is less.

The motor used in this project is the stepper motor. It is made to run according to the time specification mentioned above. This stepper motor is driven by a micro-step driver; which has 8 current settings from 0.5 to 4 which is chosen depending upon the load. The supply to the driver is given by SMPS to which the supply is AC mains. Arduino is connected to the micro-step driver. Arduino is programmed to make the wheel run according to the required time with specified delay. The flowchart to run the setup is as shown below



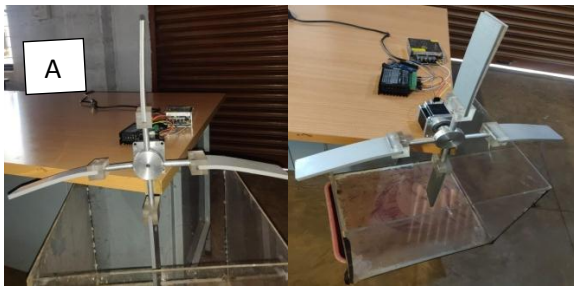
2.4 IMPLEMENTATION OF MODEL

The below model is designed and implemented for the testing of polymeric samples. The major components used for the set up are SMPS, Aurdino, Stepper motor. Setup is designed to work for the given working conditions. The wheel arrangement is placed in such a way that only polymeric samples will get dipped in the saline water tank.

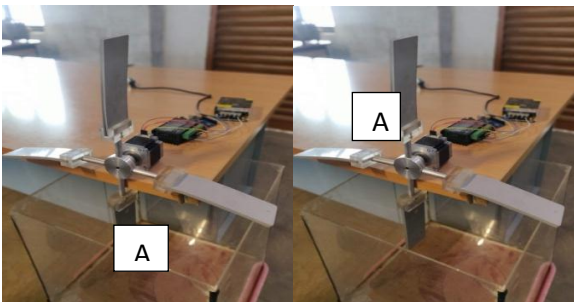


Fig3. Working Model of RWDT

Working procedure for four different conditions has follows.



3a. Energized position 3b. Resting position



3c. Immersion position 3d. De-wetting position

Fig 3a, 3b, 3c, 3d - working positions of RWDT

In fig 3a the sample A positions at a vertical position for 40 seconds. The sample is energised for 40 seconds. Then it takes 10 seconds to rotate to.

In fig 3b the sample A is now in a horizontal position. It stays for 10 seconds in this position. This position is just a rest position for that sample. Again it takes 10 seconds to move to the next position.

As in fig 3c, sample A is now in a vertical position (down). It stays for 40 seconds in this position. This position is an immersion position for that sample where the sample get dipped in the saline water. Again it takes 10 seconds to move to the next position.

As in figure 3d, sample A is now in a horizontal position after being dipped in saline water solution for 40 seconds comes to this position in 10 seconds and stay there for 10 seconds. Again it takes 10 seconds to move to the next position i.e., horizontal position and the cycle continues

3. CONCLUSION

There are many rotating wheel setups for the RWDT available in the market but are huge and costly. They are suitable only for industrial purposes and places where huge HV laboratories are present. Due to this, it is not economic to

test the small insulator samples as we require more current to run the bulky setups just to test the small samples. Hence, we can't rely on those setups to test polymeric samples. In this project rotating wheel is designed using lightweight metal. The rods to the wheel and clamps to the rods are attached through screw mechanism making it portable. Its compact size makes it economic for the test of polymeric samples thus making it cost-effective. The specification and time delay is very accurate for the program done. The output of the test is been precise. Because of its compact size, the area required to place the setup is less and can be used in small HV laboratory

REFERENCES

- [1] A S Krzma, A Haddad and M Albano, "Comparative Performance of 11kV Silicone Rubber Polymeric Insulators under Rotating Wheel Dip Test", 2014 49th International Universities Power Engineering Conference (UPEC), Year: 2014, Pages: 1 - 5
- [2] N.Vasudev, S.Vynatheya and R.T.Senthilkumar, "Comparative Performance of Silicone Rubber Insulators with IEC Stipulated Test Methods", 2012 IEEE 10th International Conference on the Properties and Applications of Dielectric Materials, Year: 2012, Pages: 1 - 4
- [3] Rahul Tripathi, G.Grzybowski, R. Ward, "Electrical Degradation of 15 kV Composite Insulator Under Accelerated Aging Condition", 2013 IEEE Electrical Insulation Conference (EIC), Year: 2013, Pages: 404 - 408
- [4] U. Kaltenbom, J. Kindersberger, R. Barsch and H. Jahn, "On the Electrical Performance of Different Insulating Materials in a Rotating-Wheel-Dip-Test", IEEE 1997 Annual Report Conference on Electrical Insulation and Dielectric Phenomena, Year: 1997 Volume: 2, Pages: 398 - 401 vol.2