

Energy Audit and Conservation of Amanora Mall; Pune

K.R.Jadhav¹, H.V.Shah², S.M.Metkari³, S.M.Hiremath⁴, S.D.Joshi⁵

^{1,2,3,4}Student, Department of Electrical Engineering, PES Modern College of Engineering, Shivaji Nagar, Pune 411005,

⁵Guide, Professor Department of Electrical Engineering, PES Modern College of Engineering, Shivaji Nagar, Pune 411005 India.

-----***-----

Abstract: The most and widely used energy in India is electrical energy. The aim of the project is to conduct an in depth study to reduce energy consumption in mall. Energy audit is basically an analysis of a facility, indicating how and where that facility can reduce energy consumption and save energy cost. In this project we are carried out the analysis and conservation of different equipment's connected in Amanora mall, which is divided into two sections basically West and East block.

The block contains the similar equipment's connected on both sides which are basically transformers, chillier plant, DG set, fire pumping equipment's, common area lighting etc. Hence auditing of such equipments and finding out the cost effective solution is the main aim of the project. We also calculated the motors efficiency, different lamp suggestions and their Lux levels and also the load on DG set and transformer etc. Hence the main objective of this project is to give the best possible cost effective solution of the equipment's connected.

Keywords: Energy audit, consumption, conservation, tariff

1. Introduction

Day by day, energy demand keeps rising so that it is essential to reduce energy consumption for that energy conservation is needed. For Conservation of energy the best option is energy audit. Energy audit is a process to determine when, where, why and how energy is used in a plant or building.

Collection of these information helps to identify the situation where there is need to improve energy efficiency and decrease production cost. Normally, an energy audit is carried out by certified energy Auditors. By conducting energy audit process in industry, employees begin considering energy as a manageable expense and try to conserve it in day-to-day action.

In this project carried out audit and conservation of energy in Amanora mall, Pune.

The main objective of this project is to evaluate use of energy in above mall for lighting purpose as well as equipments and determine the opportunities for energy saving to be adopt in mall to make it more energy efficient through energy audit. First step of energy conservation is energy audit. Audit is a systematic independent inspection of an industry or organization. Also energy audit is most important part of an energy management program which indicates the actual status of industrial facility/system with regards to energy utilization efficiencies of different activities, efficiency of different equipment's, processes and suggest remedial measures to reduce areas of energy wastage with well-defined economic implications.

2. Energy Audit

Energy audit is defined as "the verification, monitoring and analysis of use of energy including submission of technical report containing recommendation for improving energy efficiency with cost benefit analysis and an action plan to reduce energy consumption".

Energy audit is an analysis of energy consumption in building and reduces energy consumption without negatively affected outputs.

Energy audit can be classified into

i) Preliminary Audit ii) Detailed Audit.

Preliminary energy audit is relatively quick exercise; it estimates the scope for saving using the existing or easily obtained data and helps identify the areas for more detailed study.

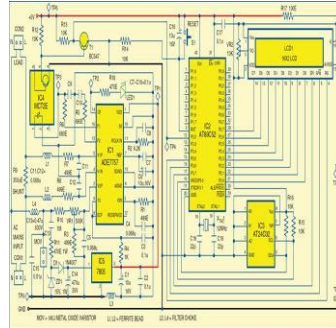

The detailed energy audit is carried out in three phases:

- Phase I – Pre Audit Phase,
- Phase II– Audit Phase,
- Phase III – Post Audit Phase.

3. Tariff

The amount of money frame by the supplier for the supply of electrical energy to various types of consumers is called as electricity tariff.

In other words, the tariff is the method of charging a consumer for consuming electric power. The tariff covers the total cost of Producing and supplying electric energy plus a reasonable cost.

The actual tariffs that the customer pay depends on the consumption of the electricity. The Consumer bill varies according to their requirements. The industrial consumers pay more tariffs Because they use more power for long times than the domestic consumers.

Types of Electricity Tariff

- Flat Demand Rate tariff
- Two-part tariff
- Power factor tariff
- Peak load tariff
- Three-part tariff

4. KWH meter

An electricity meter is a device that measures the amount of electric energy consumed by a residence, a business, or an electrically powered device. KWH meter is the electric meter that measures the amount of electrical energy in kWh that was consumed in the house. The kWh meter has a counter display that counts units of kilowatt-hour (kWh).

- **Pros and Cons of Smart Electric Meters**

Smart electric meters are electronic devices that track and record customers home electricity use. Electric utilities have been replacing old, analog meters that are read manually once a month with new, digital smart meters that automatically capture information about electricity consumption and transmit it back to electric companies. Smart meters can provide quick, accurate measurements of electricity use without the need for

estimated monthly bills or visits from meter readers. On the other hand, there are some concerns that smart meters can and do collect unnecessary information about hourly electricity use, thus violating user's privacy.

a) Advantages of Smart Meters

- Eliminating manual meter reading.
- Monitoring the electric system more quickly.
- Making it possible to use power resources more efficiently.
- Providing real-time data useful for balancing electric loads and reducing power outages.

b) Disadvantages of smart meters

- Transitioning to new technology and processes.
- Managing public reaction and customer acceptance of the new meters.
- Managing and storing vast quantities of metering data.
- Ensuring the security of metering data.

5. Specification of project

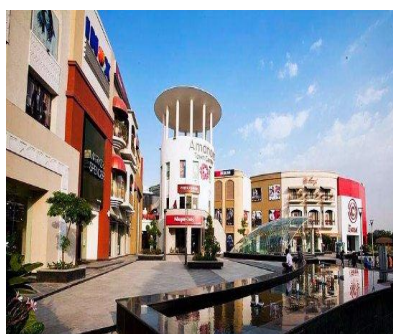
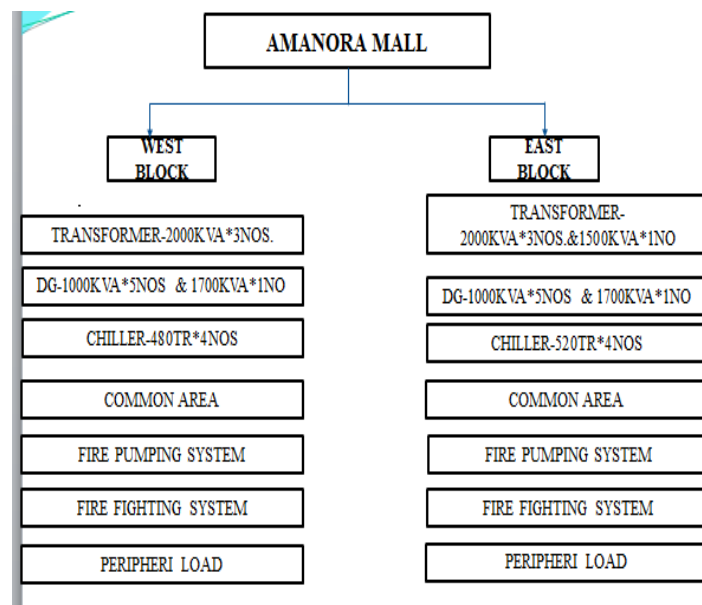

6. Energy audit process

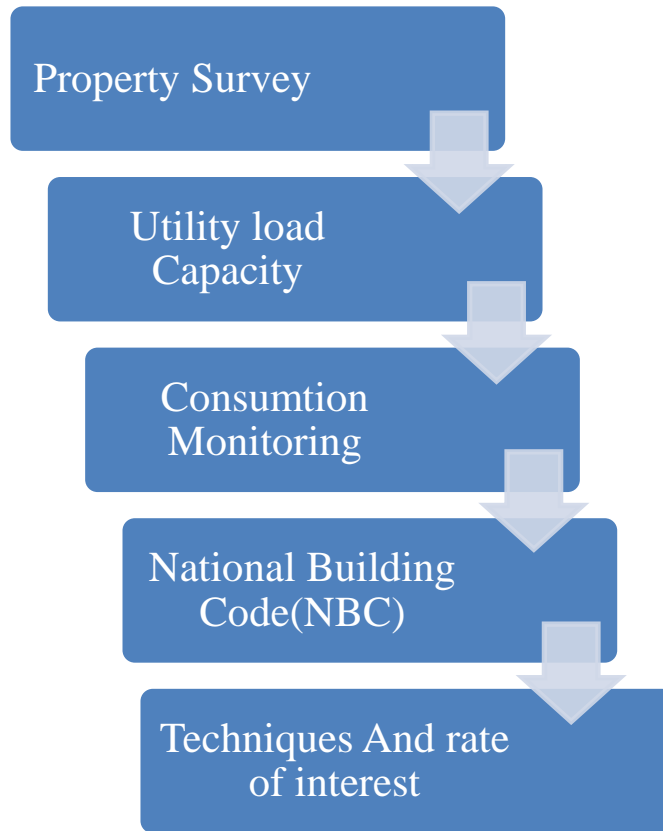

A) WORK CARRIED OUT

Load Calculation for Different Equipment

A) Chiller Load Calculations

Calculation formulae:-

- Primary Pump

$$\text{KW Power} = \rho * g * Q * H$$

Where,

ρ = Density of water in kg/m³

g = Gravity in m/sec²

Q = Flow Rate/Discharge in m³/sec

h = Height (head of water in meter)

SR NO.	EQUIPMENT	CALCULATED KW/HP RATING	STANDARD KW/HP RATING
1	PRIMARY PUMP	8KW,10.71HP	11KW,15HP
2	SECONDARY PUMP	-	55KW,75HP

3	CONDENSER	-	30KW,40HP
---	-----------	---	-----------

B) Lighting System

SR NO	PARKINGS	NO OF LAMPS	LUX MEASURED	LUX REQUIRED
1	P1	190	15200	20000
2	P2	240	39750	45000
3	P3	240	39750	45000

Total =No of lamp*Illumination of each Illumination lamp

7. Acknowledgments

The authors thank our college PES Modern College of Engineering, Pune for their support given during the paper work. Authors extend their gratitude towards electrical department, Amanora mall management.

8. Conclusion

It is concluded that the energy audit gives the amount of energy saved in particular area and methods to save energy.

Hence we conclude with the energy audit of Amanora Mall with specific energy conservation methods. With use of different equipments, energy can be consumed at particular area.

9. References

- Energy Conservation through Energy Audit (Mr.S.U.Bagwan 2017)
- NBC (National Building Code) Standard
- https://en.wikipedia.org/wiki/Energy_audit