

ANALYTICAL STUDY OF EXTENDED END PLATE CONNECTIONS IN STEEL STRUCTURES

Pawooskar Rohit Satish¹, Vaijanath A Chougule²

¹ Postgraduate Student, Department of Civil Engineering, KLS Gogte Institute of Technology, Belagavi, Karnataka, India

² Assistant Professor, Department of Civil Engineering, KLS Gogte Institute of Technology, Belagavi, Karnataka, India

Abstract - The unexpected failure of welded connections observed during the 1994 Northridge earthquake and the 1995 Kobe earthquake lead to the initiation of a research for finding an alternative connection for use in seismic resisting steel moment frames. The Extended End plate connection is considered as a suitable and efficient alternative to welding in seismic regions. The study of end-plates in moment resisting connections for beam to beam splices and beam to column connections dates to the early 1960's. These connections were primarily used in pre-engineered metal buildings. This study deals with the design and analysis of Extended End Plate Connections. In this current study, 3 configurations of Extended End plate connections are designed using AISC design parameters, for American Steel Sections and Indian Steel Sections. These connections are then modelled and analyzed by Finite Element Analysis using the ANSYS Workbench software. 6 models are prepared in total and analyzed. Using the ANSYS Workbench Software parameters such as Total Deformation, Maximum Principal Stress, Maximum Principal Strain and Hysteresis Curves are evaluated. The results obtained from the Design and Finite Element Analysis is then compared between the American Steel sections and the Indian Steel Sections to understand whether the Indian Steel Sections conform to the American Codal Provisions.

Key Words: Extended End Plate Connections, Stiffened Connection, Unstiffened Connection, Finite Element Analysis, ANSYS Workbench, Total Deformation, Maximum Principal Stress, Maximum Principal Strain, Hysteresis Curves.

1. INTRODUCTION

The study on the behavior and design of steel seismic load resisting moment frames has been going on for the past several years. In all these studies it was found that the bolted and riveted moment connections offered better performance as compared to the flange-welded moment connections. A good amount of research was funded by the FEMA (Federal Emergency Management Act) through the SAC joint venture. This research was also referred to as the SAC steel project and was divided into 2 phases. The first phase focused on determining the cause of failure of the welded connections while the second phase focused on finding an alternative to

the seismic moment resisting connections. But because of limited cyclical testing of moment end plate connections, extensive research had to be sponsored by the FEMA. However, the research sponsored by FEMA does not include the investigation of built up sections. Therefore, the Metal Building Manufacturer's Association (MBMA), a group of private companies involved in the design, fabrication, and erection of pre-engineered metal buildings, along with the American Institute of Steel Construction (AISC), had independently sponsored the testing of practical flush and extended moment end-plates under cyclic loading.

The Extended End plate connection is considered as a suitable and efficient alternative to welding in seismic regions. The study of end-plates in moment resisting connections for beam to beam splices and beam to column connections dates to the early 1960's. These connections were primarily used in pre-engineered metal buildings until the mid-1980 in the US. The Metal building industry, which primarily uses built up steel sections found these connections to be very economical for several reasons. The shop welding required for the endplates was feasible because of the welding already required for the built-up members. Also, the plate material used for the end plates could be cut from the same plate from which the flanges of the built-up sections were cut. Further, erection of the metal buildings was relatively simple due to all bolted connections, and therefore advantageous. No field welding was required, allowing construction to be done in cold conditions, and construction time to be reduced. The Extended End Plate Configurations designed and analyzed in this paper are shown below.

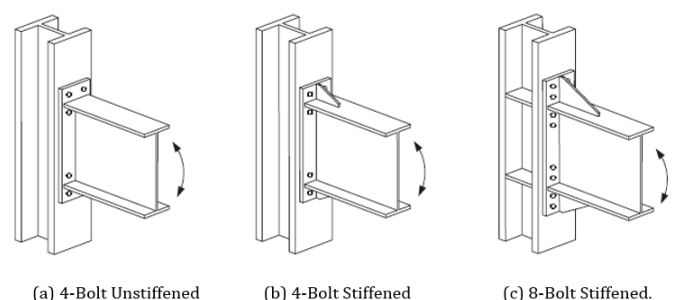

Fig-1 Extended End Plate Configurations

1.1 Literature Review

[1] **Iman Faridmehr, Mamood Md. Tahir, Mohd Hanim Osman and Mohammadamin Azimi.** They studied the cyclic behavior of connections wherein a test program was considered to clarify the cyclic characteristics of eight full-scale unstiffened extended endplates with variable parameters and one Side Plate moment connection. All specimens were subjected to 2010 AISC seismic provision loading protocol where flexural strengths were identified at each interstorey drift angle. The test specimen was casted with unstiffened extended end plate beam-column connection, wherein the column height adopted was 3m and the beam has a cantilever portion of 1.3m. A similar arrangement was casted for the Side Plate connection. The beam is restrained from lateral movement at mid-point. The sections used are Hot rolled I Shaped Perwaja Steel Sections (PSS) conforming to British Standard Institute BS EN (1993). The load is applied at the tip or edge of the beam i.e. Eccentric Loading. This loading is achieved using a hydraulic actuator. Loading sequence used for seismic evaluation was that prescribed by the AISC Specifications (2010). It is observed that the unstiffened extended end plate connection failed to meet the AISC seismic Specifications, the reason being that the strong column- weak beam principle recommended by the AISC was not considered in design. It was also observed that the unstiffened extended end plate connection also was subjected to a large shear load leading to unacceptable level of rotation. [2] **Anju Das K and Alice Johny.** The aim of their study is that to analyze the beam-column joint under seismic loading with bolts and endplates. The work is carried out at the joints having flush endplate & extended end plate with different thickness subjected to seismic loading. The sections used are CFST (Concrete Filled Steel Tube) column size: 300x300x3000x6mm., Beam size: H beam of 120x400x8x6mm, Beam length: 900mm, Endplate of size: 8,10, 12 mm., Bolt size: M22, 10.9 HSFG bolts (ISO 898-1 Gr.10.9), Bolt type: M22, 10.9 HSFG bolts (IS1367(Part3): 20002, ISO 898-1 Gr. 10.9), Grade of concrete of steel pipe: M30. Loading is applied as axial force acting at joint: 300 KN. Seismic loading is applied in a cyclic manner with 10 load steps. Modelling and Analysis is done on ANSYS Workbench Software. [3] **B.T. Adey, G.Y. Grondin and J.J.R. Cheng.** In this paper an experimental investigation of 15 cyclically loaded extended end plate connections was undertaken to assess the significance of some design parameters. The parameters investigated were beam size, bolt layout, end plate thickness, and use of extension stiffeners, welding process and weld preparation. The study involved the testing of 15 full sized extended end plate connections under cyclic loading. The loading was applied using Applied Technology Council's (ATC) Guidelines for Cyclic Seismic Testing of Components of Steel Structures (ATC 1992). The loading was applied in two blocks of loading in the elastic range, with 3 loading cycles in each block. Eleven test specimens were designed to trigger failure in the end plate rather than in the beam. [4] **Shizhe Chen, Chao Zhou and Zhan Wang.** This

study deals with the investigation of the rotational behavior of the extended end plate joints. The Numerical analysis is carried out using the ABAQUS software. Two specimens with different extended end plate joint configurations were employed for the tests. The experiments were mainly focused on initial stiffness, which reflects the mechanical behavior of panel zone. The loading is applied as an axial load placed on the column at a constant value of 325kN. The concentrated load was imposed simultaneously at each end of the steel beam by hydraulic jacks. The same was simulated using the finite element analysis software ABAQUS and a comparison between the experimental and numerical results is presented. The behaviors and the capacities of two extended end plate connections were investigated by using monotonic tests and FEM analysis. [5] **Mahyar Maali,** the paper presents the experimental and numerical results of 6 full scale beams to column connections with bolted end plates in two groups. The effects of vertical and horizontal stiffeners on the static behavior of the semi rigid beam to column bolted connections were investigated. The aim of this research was to analyze the influence of end plate connections that utilize the IPE profile with stiffeners welded on the behavior of steel connections, to provide the necessary data for improving Euro Code, efficient use of residue IPE profiles and back to the consumption cycle. The experimental models were developed to predict of failure modes the end plate connections with horizontal and vertical stiffeners under static loading in 2 groups. The FEMs of the semi-rigid vertical and horizontal stiffened bolted connections were made and their results were compared to the experimental results.

1.2 Objectives

- i. To study the various moment connections in steel structure.
- ii. To understand the design procedure for end plate moment connection in steel structure.
- iii. To compare the behavior of American steel sections to the Indian Steel Sections.
- iv. To analyze the American sections and Indian sections by Finite Element Analysis and compare the results.
- v. To observe whether the Indian steel sections satisfy the AISC Codal Provisions.

1.3 Methodology

- i. The design procedure followed by the AISC and FEMA for the design of extended end plate connection is being thoroughly studied.
- ii. Following the design procedure, design the connections for American as well as Indian steel sections.
- iii. Three types of connections need to be designed i.e. 4-Bolt Extended Unstiffened End Plate Connection. 4-Bolt Extended Stiffened End Plate Connection. 8-Bolt Extended Stiffened End Plate Connection.

- iv. Compare the design results of the American steel sections and the Indian steel sections.
- v. Model and analyze the connections of the American steel sections and Indian steel sections in ANSYS Workbench Software. Compare the analysis results of the American steel sections and Indian steel sections.

2. DESIGN PROCEDURE

The Design procedure used for designing these connections is obtained from AISC 358-16 (Prequalified Connections for Special and Intermediate Steel Moment Frame for Seismic Applications), AISC Steel Design Guide 4 (Extended End Plate Moment Connections with Seismic and Wind Application) and FEMA 351(Recommended Seismic Evaluation and Upgrade Criteria for Existing Welded Steel Moment Frame – Buildings).

The four primary design parameters for the design of extended end-plate moment connections subjected to cyclic loading are:

1. The required connection design moment
2. Connection bolt strength
3. End plate strength
4. Column flange bending strength

The procedures use yield-line theory for determination of the end plate strength and a simplified method to determine the bolt forces.

2.1 Section Properties

Table -1: Indian Section Properties

BEAM (ISMB500@ 86.9kg/m)	COLUMN (ISWB600@ 145kg/m)
Depth, D = 500 mm	Depth, D = 600 mm
Flange width, bf = 180 mm	Flange width, bf = 250 mm
Flange Thickness, tf = 17.2 mm	Flange Thickness, tf = 23.6 mm
Web thickness, tw = 10.2 mm	Web thickness, tw = 11.6 mm
Sectional Area, A = 111 cm ²	Sectional Area, A = 185 cm ²
Section Modulus, Z _x = 1.8x10 ⁶ mm ³	Section Modulus, Z _x = 3.85x10 ⁶ mm ³
Yield Strength, F _y = 250 N/mm ²	Yield Strength, F _y = 250 N/mm ²
Ultimate Strength, F _u = 410 N/mm ²	Ultimate Strength, F _u = 410 N/mm ²
HSFG 8.8 Grade Bolts with Ultimate Tensile Strength, F _t = 800 N/mm ²	

Table -2: American Section Properties

BEAM (W21 X 55)	COLUMN (W14 X 109)
Depth, D = 528 mm	Depth, D = 363 mm
Flange width, bf = 209 mm	Flange width, bf = 371 mm
Flange Thickness, tf = 13.3 mm	Flange Thickness, tf = 21.85mm
Web thickness, tw = 9.5 mm	Web thickness, tw = 13.34mm
Sectional Area, A = 104.51 cm ²	Sectional Area, A = 206.45 cm ²
Section Modulus, Z _x = 2x10 ⁶ mm ³	Section Modulus, Z _x = 7.32x10 ⁶ mm ³
Yield Strength, F _y = 345 N/mm ²	Yield Strength, F _y = 345 N/mm ²
Ultimate Strength, F _u = 448 N/mm ²	Ultimate Strength, F _u = 448 N/mm ²
ASTM A490 Bolts with Ultimate Tensile Strength, F _t = 780 N/mm ²	
ASTM A325 Bolts with Ultimate Tensile Strength, F _t = 621 N/mm ²	

2.2 Design Results

The connections are designed both manually and by using Microsoft Excel software following the design procedure obtained from AISC 358-16 (Prequalified Connections for Special and Intermediate Steel Moment Frame for Seismic Applications), AISC Steel Design Guide 4 (Extended End Plate Moment Connections with Seismic and Wind Application). The design is carried out for a Shear Force = 178kN.

The following design results are obtained after designing the Connections for the 3 configurations.

Table -3: Design Results of 4 – Bolt Extended Unstiffened End Plate Connection

American 4-Bolt Unstiffened	Indian 4-Bolt Unstiffened
Moment at the face of the column, M _{uc} = 908 kN-m	Moment at the face of the column, M _{uc} = 592 kN-m
Bolt Diameter d _b = 32 mm	Bolt Diameter d _b = 30 mm
No prying bolt moment ØM _{np} = 953.08 kN-m	No prying bolt moment ØM _{np} = 917 kN-m
End Plate Thickness, t _p = 32 mm	End Plate Thickness, t _p = 32 mm
Factored beam Flange Force, F _{fu} = 1762 kN	Factored beam Flange Force, F _{fu} = 1227 kN

Minimum Design Strength Min $\phi R_n = 1087$ kN	Minimum Design Strength Min $\phi R_n = 609$ kN
Stiffener Design Force $F_{cu} = 677$ kN	Stiffener Design Force $F_{cu} = 617$ kN
Column Flange Stiffener thickness, $t = 13$ mm	Column Flange Stiffener thickness, $t = 30$ mm

Stiffener Design Force $F_{cu} = 519$ kN	Stiffener Design Force $F_{cu} = 467$ kN
End Plate Stiffener used 13mm x 152mm x 267mm	End Plate Stiffener used 13mm x 120mm x 244mm
Column Flange Stiffener thickness, $t = 13$ mm	Column Flange Stiffener thickness, $t = 25$ mm

Table - 4: Design Results of 4 – Bolt Extended Stiffened End Plate Connection

American 4-Bolt Stiffened	Indian 4-Bolt Stiffened
Moment at the face of the column, $M_{uc} = 908$ kN-m	Moment at the face of the column, $M_{uc} = 592$ kN-m
Bolt Diameter $d_b = 32$ mm	Bolt Diameter $d_b = 30$ mm
No prying bolt moment $\phi M_{np} = 953.08$ kN-m	No prying bolt moment $\phi M_{np} = 917$ kN-m
End Plate Thickness, $t_p = 29$ mm	End Plate Thickness, $t_p = 29$ mm
Factored beam Flange Force, $F_{fu} = 1762$ kN	Factored beam Flange Force, $F_{fu} = 1227$ kN
Minimum Design Strength Min $\phi R_n = 1065$ kN	Minimum Design Strength Min $\phi R_n = 596$ kN
Stiffener Design Force $F_{cu} = 700$ kN	Stiffener Design Force $F_{cu} = 631$ kN
End Plate Stiffener used 9.5 mm x 92 mm x 165 mm	End Plate Stiffener used 7.6 mm x 66 mm x 152 mm
Column Flange Stiffener thickness, $t = 13$ mm	Column Flange Stiffener thickness, $t = 30$ mm

Table - 5: Design Results of 8 – Bolt Extended Stiffened End Plate Connection

American 8-Bolt Stiffened	Indian 8-Bolt Stiffened
Moment at the face of the column, $M_{uc} = 913$ kN-m	Moment at the face of the column, $M_{uc} = 600$ kN-m
Bolt Diameter $d_b = 25$ mm	Bolt Diameter $d_b = 20$ mm
No prying bolt moment $\phi M_{np} = 972$ kN-m	No prying bolt moment $\phi M_{np} = 753$ kN-m
End Plate Thickness, $t_p = 23$ mm	End Plate Thickness, $t_p = 25$ mm
Factored beam Flange Force, $F_{fu} = 1774$ kN	Factored beam Flange Force, $F_{fu} = 1242$ kN
Minimum Design Strength Min $\phi R_n = 1255$ kN	Minimum Design Strength Min $\phi R_n = 774$ kN

3. MODELLING IN ANSYS

The Extended End Plate Connections designed in Excel are now modeled and analyzed by Finite Element Analysis using the ANSYS Workbench Software. Six models are prepared in total consisting of three American steel sections and three Indian steel sections. The modeling is done in SpaceClaim using the Static Structural parameter for analysis. The models prepared are shown below.

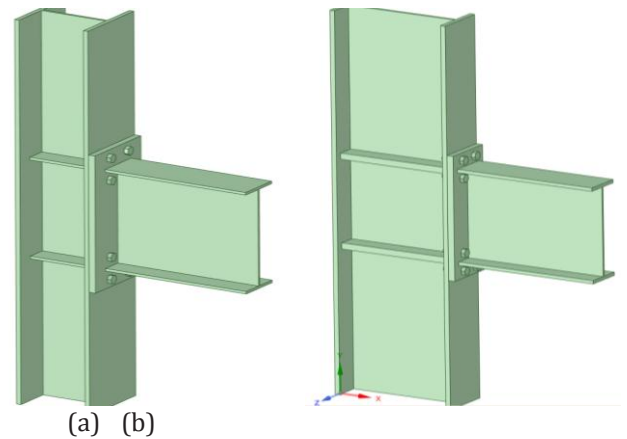

Fig -2: (a) American section 4-Bolt Extended Unstiffened End Plate Connection (b) Indian section 4-Bolt Extended Unstiffened End Plate Connection

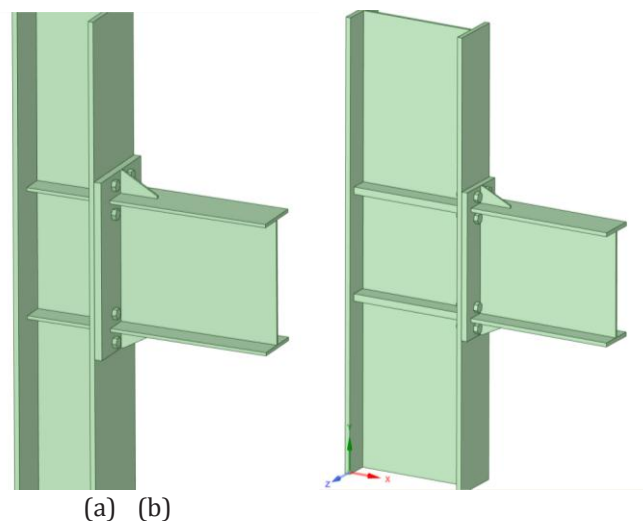

Fig -3: (a) American section 4-Bolt Extended Stiffened End Plate Connection (b) Indian section 4-Bolt Extended Stiffened End Plate Connection

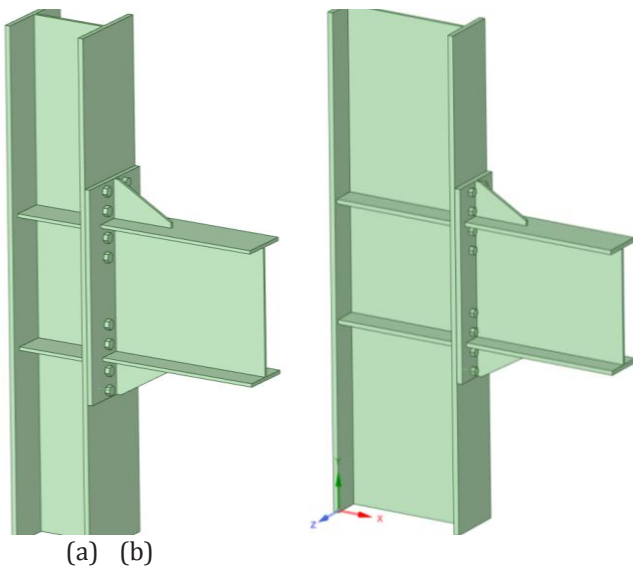

Fig -4: (a) American section 8-Bolt Extended Stiffened End Plate Connection (b) Indian section 8-Bolt Extended Stiffened End Plate Connection

4. FEM ANALYSIS

4.1 Eccentric Loading

Eccentric load is applied as a concentrated/point load at the edge of the beam. In this analysis the Column is fixed at both the ends for all 6 models and a concentrated load of 200 kN is applied at the beam edge which is unsupported. This test is carried out to understand the behavior of these connections and to compare their results under normal loading conditions.

Three parameters are tested in this analysis

1. Total Deformation
2. Maximum Principal Stress
3. Maximum Principal Strain

The results of obtained by testing for these parameters will be compared to understand whether the Indian Steel Sections Conform to the American (AISC) Codal Provisions.

4.2 Seismic Loading

The loading sequence used for the seismic evaluation was that prescribed by the AISC Specifications 2010. The AISC protocol identifies a number of loading cycles at each interstorey drift angle. The interstorey drift angle capacity is believed to be the key parameter in evaluation of the cyclic performance of the specimens. The loading is applied as a displacement of 2mm/s. The load steps are performed on the ANSYS Workbench Software and the results are plotted as graphs.

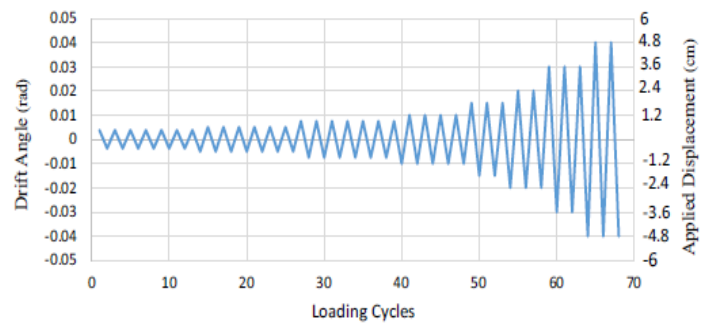

Continue Loading at increments of $\theta=0.01$ radians, with two cycle of loading at

Fig-5: Loading Protocol

5. ANALYSIS RESULTS

5.1 Total Deformation

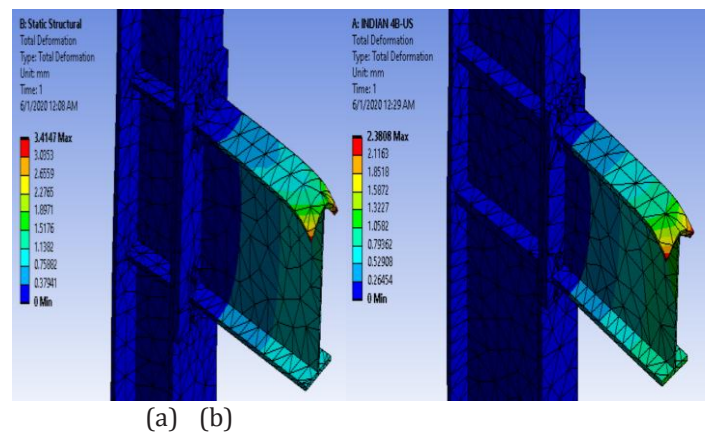

Fig -6: (a) American section 4-Bolt Extended Unstiffened End Plate Connection (b) Indian section 4-Bolt Extended Unstiffened End Plate Connection

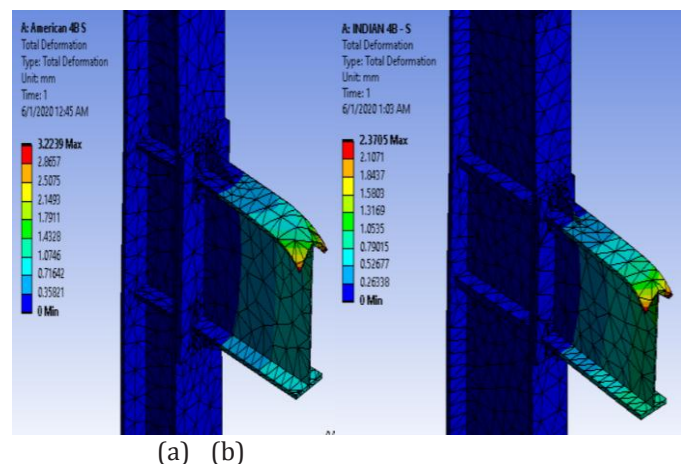
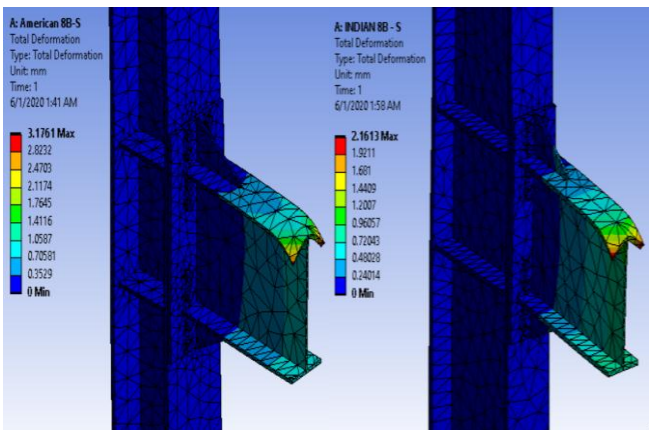
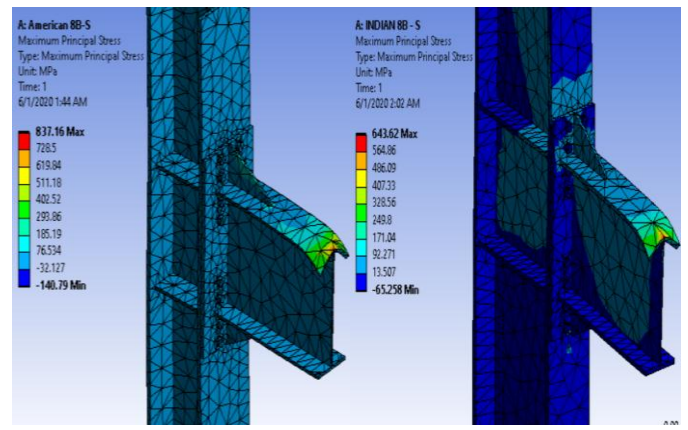

Fig -7: (a) American section 4-Bolt Extended Stiffened End Plate Connection (b) Indian section 4-Bolt Extended Stiffened End Plate Connection



(a) (b)

Fig-8: (a) American section 8-Bolt Extended Stiffened End Plate Connection (b) Indian section 8-Bolt Extended Stiffened End Plate Connection



(a) (b)

Fig-11: (a) American section 8-Bolt Extended Stiffened End Plate Connection (b) Indian section 8-Bolt Extended Stiffened End Plate Connection

5.2 Maximum Principal Stress

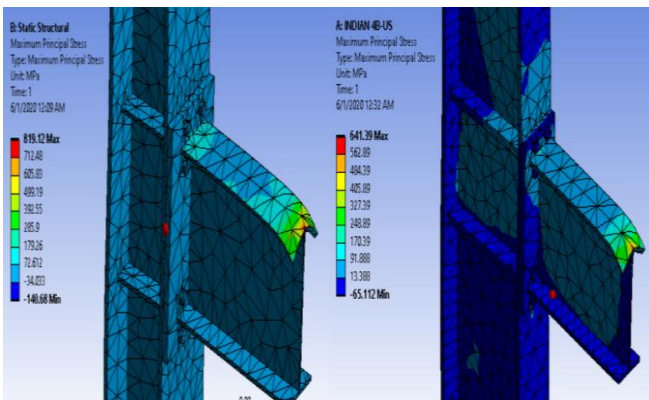

(a) (b)

Fig-9: (a) American section 4-Bolt Extended Unstiffened End Plate Connection (b) Indian section 4-Bolt Extended Unstiffened End Plate Connection

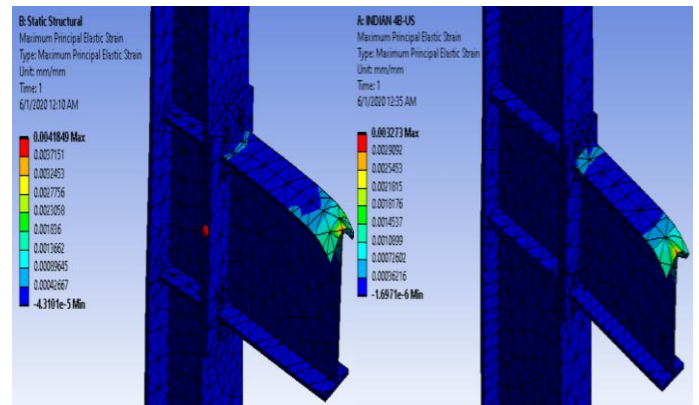

(a) (b)

Fig-12: (a) American section 4-Bolt Extended Unstiffened End Plate Connection (b) Indian section 4-Bolt Extended Unstiffened End Plate Connection

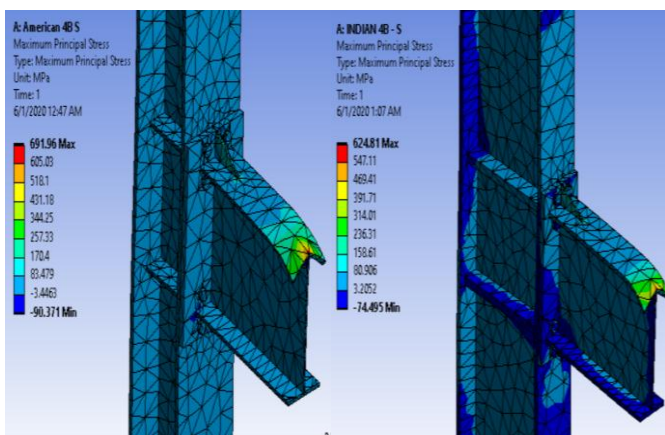

(a) (b)

Fig-10: (a) American section 4-Bolt Extended Stiffened End Plate Connection (b) Indian section 4-Bolt Extended Stiffened End Plate Connection

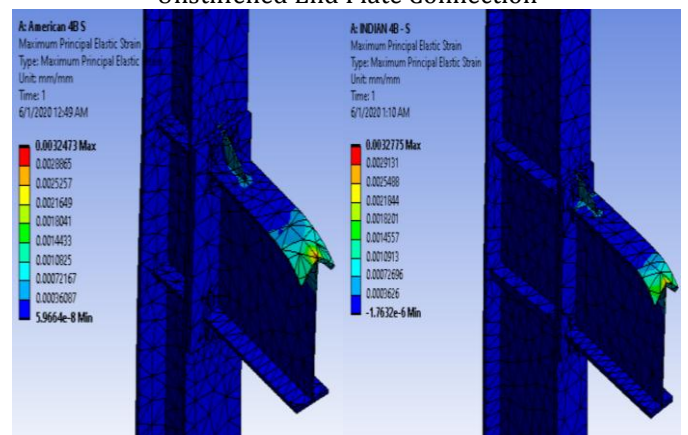

(a) (b)

Fig-13: (a) American section 4-Bolt Extended Stiffened End Plate Connection (b) Indian section 4-Bolt Extended Stiffened End Plate Connection

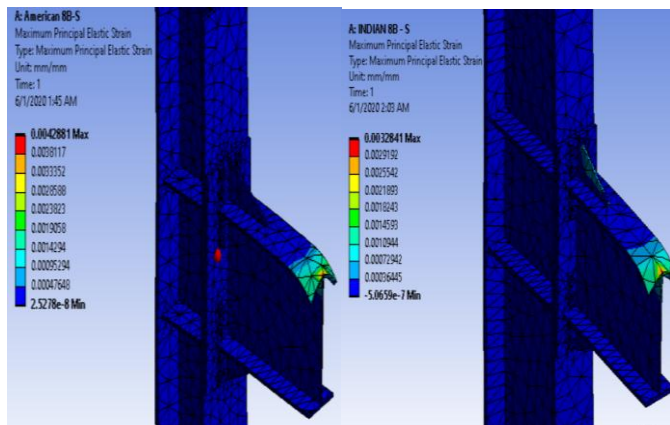

(a) (b)

Fig -14: (a) American section 8-Bolt Extended Stiffened End Plate Connection (b) Indian section 8-Bolt Extended Stiffened End Plate Connection

The results obtained are tabulated as shown below. The unit of strain is mm/mm as mentioned in the figures above.

Table -6: 4 -Bolt Extended Unstiffened End Plate Connection

Parameters	American Section	Indian Section
Total Deformation	3.41 mm	2.38 mm
Max. Principal Stress	819.12 N/mm ²	641.39 N/mm ²
Max. Principal Strain	0.0042	0.0032

Table -7: 4 -Bolt Extended Stiffened End Plate Connection

Parameters	American Section	Indian Section
Total Deformation	3.22 mm	2.37 mm
Max. Principal Stress	691.96 N/mm ²	624.81 N/mm ²
Max. Principal Strain	0.0032	0.0032

Table -8: 8 -Bolt Extended Stiffened End Plate Connection

Parameters	American Section	Indian Section
Total Deformation	3.17 mm	2.16 mm
Max. Principal Stress	837.16 N/mm ²	643.6 N/mm ²
Max. Principal Strain	0.0042	0.0032

5.4 Seismic Analysis Results

The seismic analysis results are plotted as a graph of Moment at the column face vs Total Storey Drift. These graphs are obtained as Hysteresis Curves.

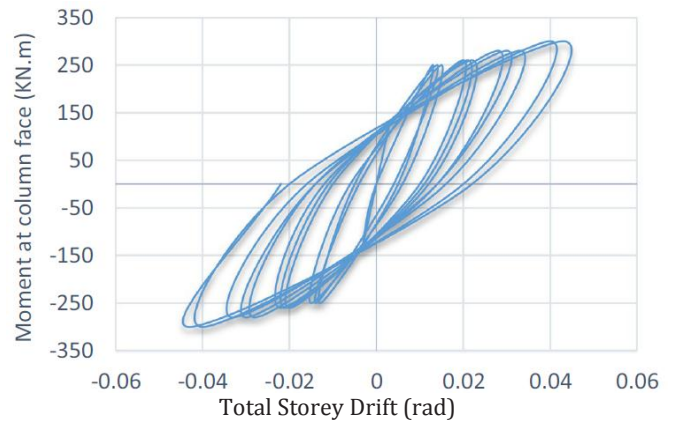

Fig-15: American Section 4 -Bolt Extended Unstiffened End Plate Connection

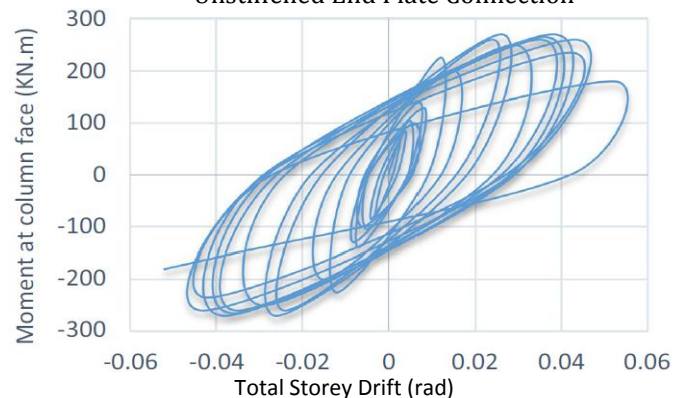

Fig-16: Indian Section 4 -Bolt Extended Unstiffened End Plate Connection

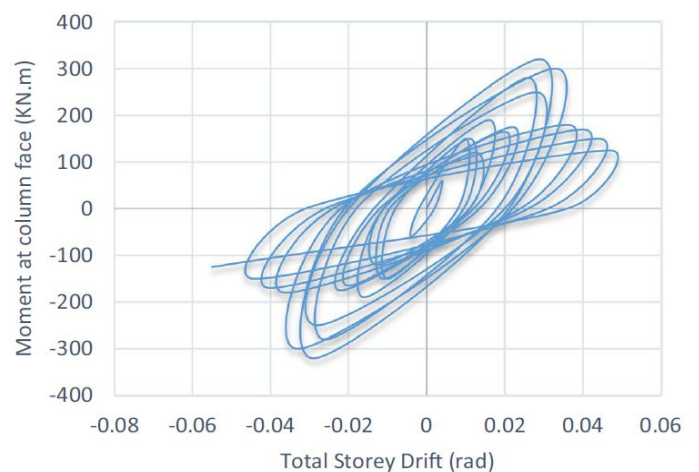

Fig-17: American Section 4 -Bolt Extended Stiffened End Plate Connection

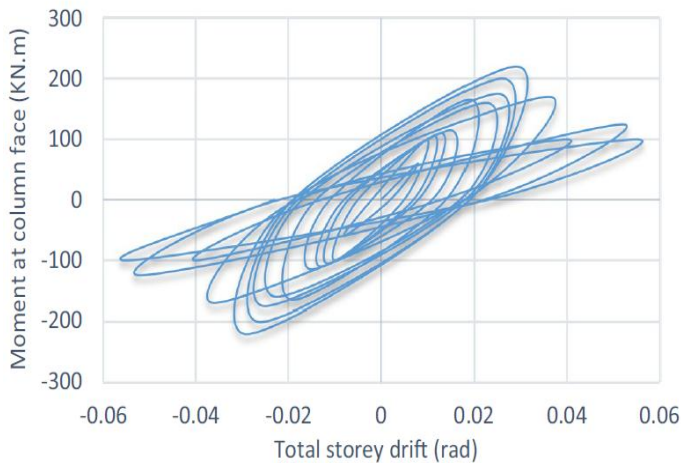

Fig-18: Indian Section 4 -Bolt Extended Stiffened End Plate Connection

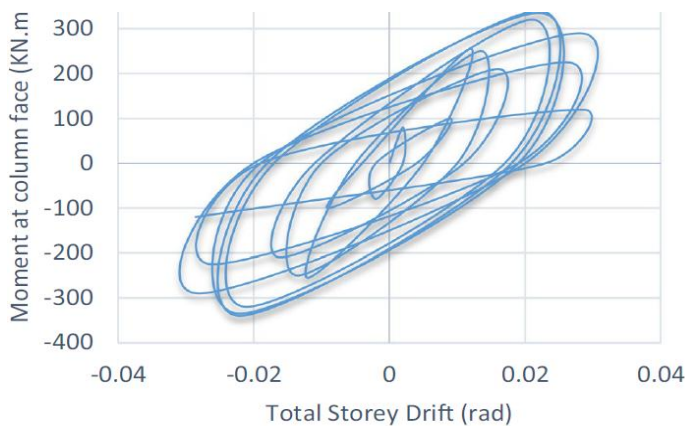

Fig-19: American Section 8 -Bolt Extended Stiffened End Plate Connection

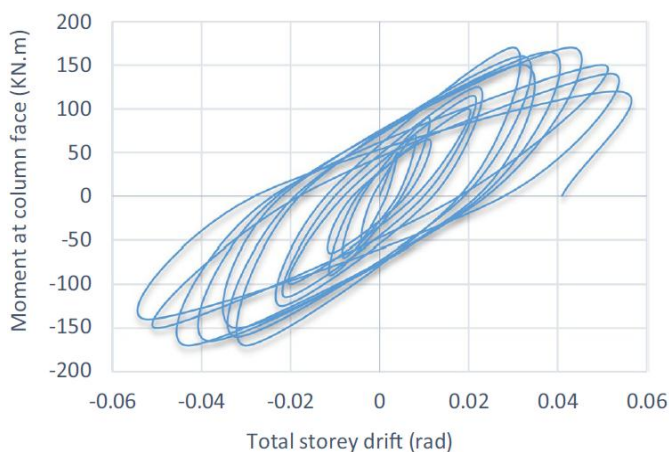

Fig-20: Indian Section 8 -Bolt Extended Stiffened End Plate Connection

6. CONCLUSIONS

This Study deals with design and analysis of Extended End Plate Connections in Steel Structures designed using AISC Codal Provisions. The design is carried out on 3 configurations of the Extended End Plate Connections for both American and Indian Steel sections. FEM analysis is carried out for these sections using the ANSYS Workbench Software. The following conclusions are obtained from this study.

1. The Design results show us that the moment capacity and design strength of the Extended End Plate Connections of American Steel Sections is higher than the Extended End Plate Connections of Indian Steel Sections.
2. From the design results it can also be observed that the thickness of the end plate impacts the stiffness of the connection i.e. increasing the thickness of the end plate increases the stiffness of the connection.
3. It can also be seen from the design results that the Beam Flange Force of Extended End Plate connection of the American Steel Sections is higher than that of the Extended End Plate connection of the Indian Steel Sections.
4. From the design results it can also be observed that the No Prying Bolt Moment of Extended End Plate connection of the American Steel Sections is higher than that of the Extended End Plate connection of the Indian Steel Sections.
5. From the analysis results it can be observed that the Extended End Plate connection of Indian Steel Sections undergoes nearly 30% less Total Deformation as compared to Extended End Plate connection of the American Steel Sections.
6. It can also be observed that the Extended End Plate connection of Indian Steel Sections are subjected to nearly 20% less Maximum Principal Stress as compared to Extended End Plate connection of the American Steel Sections.
7. From the analysis results it can also be observed that the Extended End Plate connection of Indian Steel Sections undergoes nearly 20% less Maximum Principal Strain as compared to Extended End Plate connection of the American Steel Sections.
8. The hysteresis curves obtained from the seismic analysis show us that the Moment generated at the column face is higher in case of the Extended End Plate Connections of American Steel Sections as compared to Extended End Plate Connections of Indian Steel Sections.
9. It can also be observed from the hysteresis curves that the Total Storey drift is comparatively less in Extended End Plate connections of Indian Steel Sections as compared to Extended End Plate connections of the American Steel Sections.

The results obtained from Eccentric Load analysis and Seismic Analysis show us that the Extended End Plate Connections for Indian Steel Sections designed using the American Codes (AISC) satisfies the American Codal Provisions.

REFERENCES

- [1] AISC 341-16. (2016). *Seismic provisions for structural, steel buildings*. Chicago: American Institute of Steel Construction.
- [2] Federal Emergency Management Agency (FEMA) (2000a). Recommended seismic design criteria for new steel moment-frame Buildings. FEMA-350, prepared by the SEAOC-ATC-CUREE (SAC) Joint Venture for FEMA, Washington, DC.
- [3] Iman Faridmehr, Mamood Md. Tahir, Mohd Hanim Osman and Mohammadamin Azimi, "Cyclic Behaviour Of Fully-rigid And Semi-rigid Steel Beam-to-column Connections". International Journal of Steel Structures (2019).
- [4] Krishnamurthy, N. (1978), "A Fresh look at Bolted End Plate Behavior and Design". Engineering Journal, AISC, 15(2), 39-49.
- [5] Adey, B.T., Grondin, G.Y., Cheng, J.J.R (1998), "Extended End Plate Moment Connections Under Cyclic Loading". Journal of Constructional Steel Research, Elsevier Applied Science, 46(1-3), Paper No. 133
- [6] Cheol-Ho Lee, Jong-Hyun Jung and Sung-Yong Kim, "Cyclic Seismic Performance of Weak-axis RBS Welded Steel Moment Connections". International Journal of Steel Structures (2019).
- [7] Anju Das K and Alice Johny, "Study on Performance of Beam-column Joint with Endplates & Bolts Under Seismic Loading". International Research Journal of Engineering and Technology (2019).
- [8] Seyedbabak momenzadeh, mohammad taghi kazemi and masoud hoseinzadeh asl, studied "Seismic Performance of Reduced Web Section Moment Connections". International Journal of Steel Structures (2017.)
- [9] Swati Ajay Kulkarni and Gaurang Vesmawala, "Study of Steel Moment Connection with And Without Reduced Beam Section". Published by ELESVIER, Case Study in Structural Engineering (2014).
- [10] Cheol-Ho Lee, M. ASCE, Sang-Woo Jeon, Jin-Ho Kim and Chia-Ming Uang, M. ASCE, "Effects of Panel Zone Strength and Beam Web Connection Method on Seismic Performance of Reduced Beam Section Steel Moment Connection", ASCE Journal of Structural Engineering (2005).
- [11] AISC 358-16 2018, Prequalified Connections for Special and Intermediate Steel Moment Frames for Seismic Applications.
- [12] Federal Emergency Management ACT, FEMA -351 2000 Recommended Seismic Evaluation and Upgrade Criteria for Existing Welded Steel Moment-Frame Buildings.
- [13] AISC Steel Design Guide 4, Extended End-Plate Moment Connections for Seismic and Wind Applications.
- [14] R. E. S. Ismail, A.S. Fahmy, A. M. Khalifa and Y. M. Mohamed, "Numerical Study on Ultimate Behavior of Bolted End-Plate Steel Connections" Latin American Journal of Solids and Structures (2015).
- [15] Mays, T. W., (2000), "Application of Finite Element Method to the seismic Design and Analysis of Large Moment End Plate Connections, Ph.D. Dissertation, Virginia Polytechnic Institute and State University, Blacksburg, Virginia.

BIOGRAPHIES



Pawooskar Rohit Satish

M.Tech Student, Department of Civil Engineering, KLS Gogte Institute of Technology, Belagavi, Karnataka, India.



Vaijanath A Chougule

Assistant Professor, Department of Civil Engineering, KLS Gogte Institute of Technology, Belagavi, Karnataka, India.