

# Highway Hybrid Solar And Wind Energy System By Using MPPT Technique

AJIT KUMAR

M.Tech Student Dept.Of Electrical & Electronics Engineering, GIET University, Gunupur, Odisha

\*\*\*

**Abstract** - Energy saving is biggest issue now a days, renewable energy is playing a big role in producing electricity, among them solar and wind are popular renewable energy sources. This thesis is an inspiring piece of technology that could become a reality and practical in the near future, interesting is that it may solve many problems that have been piling up from the past and some current issues. Energy produced by windmills, which depend on the wind blowing. Energy from hybrid solar and wind turbines placed on the side of a roadway or in the center of a divided highway. This system of electrical power generation utilizes wind draft force from vehicles traveling on roadways. Moving at high speed, vehicles push away air as they travel, producing a lot of energy. By placing hybrid solar panel with vertical wind turbines on the side of a road or in the center of the road energy can be captured. Such as in solar energy consumption fast tracking of global maximum power point (MPP) is a challenge. MPP highly depends on atmospheric conditions, so maximum power point tracking (MPPT) technique should be good enough to track MPP in dynamic atmospheric conditions. Partial shading gives local MPPs and one global MPP, partial shaded module is good for better efficiency. MPP also highly depends on the load, as the load changes MPP changes. Extra power need to store because sometimes load requirement is lesser than the generation, in this situation a battery is needed and in night time when PV module not able to generate, power can draw from the battery and also form windmill. If the batteries run low, the engine generator driven by conventional fuels can also be integrated to recharge the batteries, so that continuous power will be supplied meeting to the load demands from time to time. In this thesis advance the technique of more solar energy capture through photovoltaic by using INC method MPPT technique and also adding advance structure of vertical wind mill in hybrid solar wind energy system that can be used in center of a divided highway, parks, sea beaches and high storage building.

**Key Words:** Vertical wind turbines, solar energy consumption, global maximum power point, partial shaded module.

**1. INTRODUCTION:** In 21st century energy crises, drag every researchers concentration towards the renewable energies, renewable energy is a source of clean and green energy. Among all renewable energies photovoltaic (PV) and wind are considered to be good sources of energy. Many researches are going on in the area of PV system, big challenge in this area is to track maximum power point (MPP) in the dynamic atmospheric conditions and shading condition because MPP varies with change in temperature and insolation.

To track maximum power point, technique use called maximum power point tracking technique (MPPT). In which our main concentration is towards the fast tracking of MPP and operate PV system in global maximum power point. We are using Incremental conductance (INC) methods because of its easy implementation and effective tracking. Boost converter is used as intermediate converter to perform switching and regulated output. Battery is used to store extra power from PV system.

Wind speed is low in summer whereas the solar radiation is brightest and longest. The wind is strong in monsoon months whereas less sunlight is available owing to cloud cover. Because the peak operating times of wind and solar systems occur at different times of the day and year, hybrid systems are more likely to produce, dependable power to our demands. Hybrid systems provide power through the energy stored in batteries. If the batteries run low, the engine generator driven by conventional fuels can also be integrated to recharge the batteries, so that continuous power will be supplied meeting to the load demands from time to time.

**2. HYBRID SYSTEM:** Photovoltaic system is use in conjunction with photovoltaic array, micro wind turbines, batteries, solar controller, wind controller, inverter etc., system is called hybrid system. All energy is used by DC load as well as AC load after inverting and all remaining are stored in batteries. In this we using from both solar as well as wind.

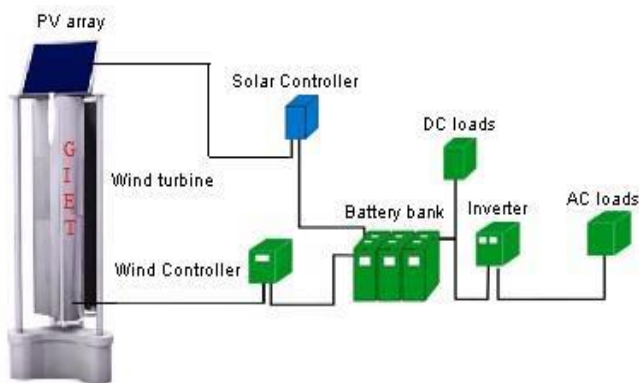

Figure 1: Hybrid system

Table 1: Principle of operation of controller

Condition	$\dot{p}$	$\dot{v}$	Comparator output		S	Switch	v
			$X_p$	$X_v$			
$v \leq V_{mpp}$	$>0$	$>0$	1	1	0	Opens	Increase
$v \leq V_{mpp}$	$\leq 0$	$\leq 0$	0	0	0	Opens	Increase
$v > V_{mpp}$	$>0$	$>0$	1	0	1	Closes	Decrease
$v > V_{mpp}$	$\leq 0$	$\leq 0$	0	1	1	Closes	Decrease

**2.1. INC Method:** INC method is implemented first with constant temperature, constant irradiation, after constant temperature; varying irradiation and varying temperature; constant irradiation. Partial shading of array is a big problem because in this condition we have many local maxima and one global maxima, so it's tough to get global maxima in P-V curve. In this we simulated two modules one is fully shaded and other is partially shaded, P-V curve and I-V curves plotted in this situation. Analog implementation of MPPT is easy, cheap and faster.

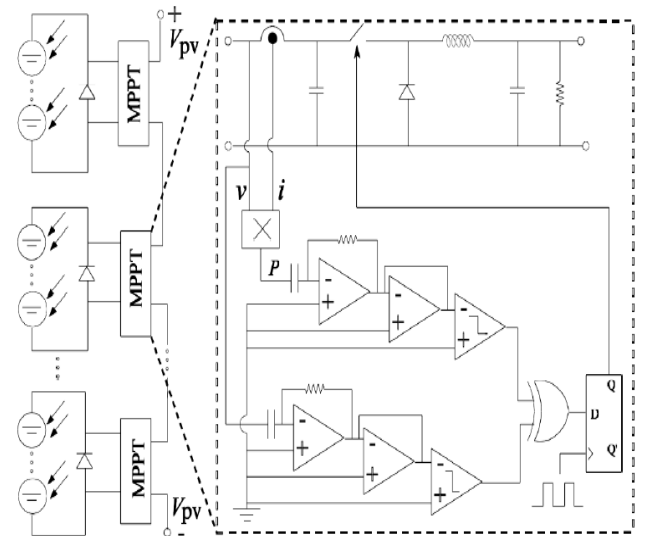

Figure 3: Analog implementation of MPPT

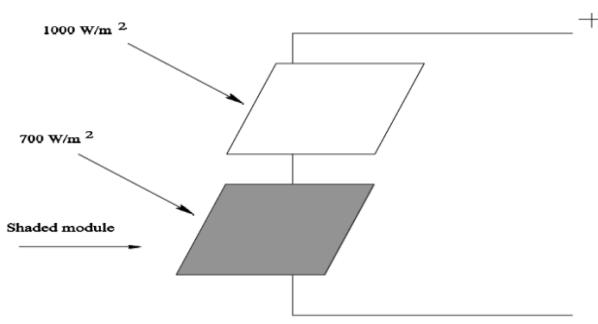

Figure 2: Block diagram of partial shaded module

After using INC method partial shading condition output will be shown in figure 4.

**2.2. Analog Implementation Of MPPT:** Analog implementation of MPPT is faster and cheaper, MPPT consist of differentiator, comparator, XOR gate and D flip flop. MPPT can perform in analog or digital both domains, analog domain is faster than digital domain because do not need I-V and P-V plot and cheaper also, partial shading occur instantaneous, so faster response of MPPT is require. Power will get through simple multiplication of current and voltage  $p = v.i$  and  $\dot{v}$ ,  $\dot{p}$  will get through differentiator, after that comparator to compare the condition and Boolean expression use to execute by XOR gate. High frequency can damage the switch to control that D flip flop is used.

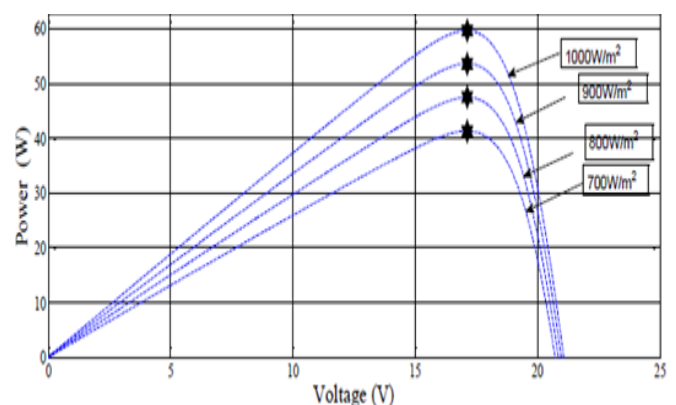

Figure 4: P-V characteristics at constant temperature (25°C)

**3. VERTICAL AXIS WIND TURBINES:** Vertical axis wind turbine in which main rotor shaft is set transverse to the wind while the main components are located at the base of the turbine. This arrangement permits the

generator and casing to be located close to the ground, facilitating service and repair.

**3.1. Vertical Windmill Blades:** Vertical windmill blades are made up of carbon fibre to make it light, strong and easy to transport. General aerodynamics concept is used for designing of windmill blades.

**4. Generator Design:** Neodymium Magnet, There are several types of permanent magnets available but the Neodymium magnet has been a key technological development that allows practical and efficient alternators to be built. The high strength of Neodymium is part of reason which makes computer hard drives so compact. Now the material is available commercially for all style of functions. Many sizes are now available for the perfect use in the DIY alternators. Below Fig. 5, shows some of the common sizes of magnets available. In our generator square type neodymium magnets are used as it has higher field of attraction than circular type magnets.

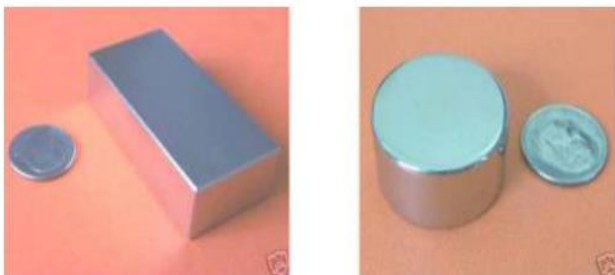

**Figure 5:** Neodymium Magnets.

Magnetic field is the technical term for the lines of force which are often drawn to picture the magnetic field around the magnet. The magnetic field intensity is measured in either Tesla or Gauss. The field intensity stronger as we catch up with to the magnet, since the lines get closer together. The magnets we prefer have poles on the faces with the most surface area. So, for maximum intensity using square type neodymium magnet.

**5. CONCLUSION:** Nature has provided ample opportunities to mankind to make best use of its resources and still maintain its beauty. In this context, the proposed hybrid solar wind system provides an elegant integration of the wind turbine and solar PV to extract optimum energy from the two sources. In this thesis advance the technique of more solar energy capture through photovoltaic by using INC method MPPT technique in partial shading. We propose a module integrated converters structures. This is achieved by dc-dc converter architecture and shaded module in solar plates to track

more energy. The analog implementation of MPPT is easy, faster and cheaper. Moreover, in order to show its tracking performance, system has been evaluated for different loading conditions. Also adding advance structure of vertical windmill in hybrid solar wind energy system. Vertical windmill blades made up of carbon fiber, so it is cheap and strong. In our generator square type neodymium magnets are used as it has higher field of attraction. This is useful for a longer period of life than using other magnets. This axial flow generator requires no starting torque when compared with other generators, hence smooth operation will be maintained during overall operation and the speed and efficiency will be high. This is very compact in size hence it is easy to couple with blades of the turbine. This technology can revolutionize the roads and that can be used in center of a divided highway, parks, sea beaches and high storage building, give energy to the street lights, nearby shops and house hold electric equipment without interruption.

## REFERENCES

- [1] T. Eswam and P. L. Chapman, "Comparison of photovoltaic array maximum power point tracking techniques," *IEEE Trans. on Energy Conversion*, vol. 22, no. 2, June 2007
- [2] W. Xiao, N. Ozog, and W. G. Dunford, "Topology study of photovoltaic interface for maximum power point tracking," *IEEE Trans. on Ind. Electron.*, vol. 54, no. 3, pp. 1696- 1704, June 2007
- [3] M. G. Villalva, J. R. Gazoli, and E. R. Filho, "Comprehensive approach to modeling and simulation of photovoltaic arrays," *IEEE Trans. on power Electron.* vol. 24, no. 5, May 2009.
- [4] A. Roman, R. Alonso, P. Ibanez, S. Elorduizapatarietxe and D. Goitia, "Intelligent PV module for grid-connected PV systems," *IEEE Trans. on Ind. Electron.*, Vol. 53, No. 4, Aug. 2006
- [5] R. J. Wai, Wen-Hung and C. Y. Lin, "High performance stand-alone photovoltaic generation System," *IEEE Trans. on Ind. Electron.*, vol. 55, no. 1, Jan. 2008.
- [6] Natsheh, E.M.; Albarbar, A.; Yazdani, J., "Modeling and control for smart grid integration of solar/wind energy conversion system," 2nd IEEE PES International Conference and Exhibition on Innovative Smart Grid Technologies (ISGT Europe), pp.1-8, 5-7 Dec. 2011.

## BIOGRAPHIES



Ajit Kumar

*M.Tech in Power Electronics,  
from GIET University.*

He worked and research in the field of electrical & electronics.