

FAULT ACKNOWLEDGEMENT SYSTEM FOR UPS USING IOT

A. Keerthana ¹, M.A. Rammiya ², G. Yalini Devi ³, A. Karuppasamy ⁴

^{1,2,3} UG Scholars, Dept. of EEE, Kamaraj College of Engineering & Technology, Madurai, Tamil Nadu, India.

⁴ Professor, Dept. of EEE, Kamaraj College of Engineering & Technology, Madurai, Tamil Nadu, India.

Abstract – Battery management system (BMS) forms a crucial system component in various applications like electric vehicles (EV), hybrid electric vehicles (HEV), uninterrupted power supplies (UPS), telecommunications and so on. The accuracy of these systems has always been a point of discussion as they generally give an error of maximum 10% considering all the parameters together. Batteries are the heart of the automation system, and its applications are more in all the fields, where the electrical supply requires. The periodical monitoring/observations are required for battery source to provide continuous power to the load without any interruption. Our proposed system monitors and stores parameters that provide an indication of the lead acid battery's acid level, state of charge, voltage, current, and the remaining charge capacity in a real-time scenario. Wireless local area network is used as the backbone network. The information collect from all the associated battery clients in the system is analyzed. The malfunction of the battery status are continuously monitored based on sudden charge & discharge voltage of battery bank and battery conditions are viewed in the cloud with help of IoT module.

Key Words: UPS, Battery, IoT module.

1. INTRODUCTION

The industrial process expansion has become very complex in the electronics system. In such developing industrial field fault detection and fault isolation is very important. This proposed work reduces the system in identifying the fault in the UPS. The vulnerable part in the UPS is the battery. Battery performance is influenced by factors such as depth of discharge (DoD), temperature and charging time. This paper attempts to provide the current level and voltage level using Internet of Things. By depending on the output of the battery fault can be analyzed. The battery is a device that converts the chemical energy into electrical energy through electrochemical reaction. Lead Acid battery is the most commonly used battery in UPS. To know the present status of the battery some important parameters are to be measured in regular interval. The important parameters are terminal voltage, load current, discharge current, room temperature of each battery used in the battery. The UPS that are used in the industries require electric power for smooth operation. The systems are equipped with lead-acid batteries as an alternate source of electric power.

2. BLOCK DIAGRAM

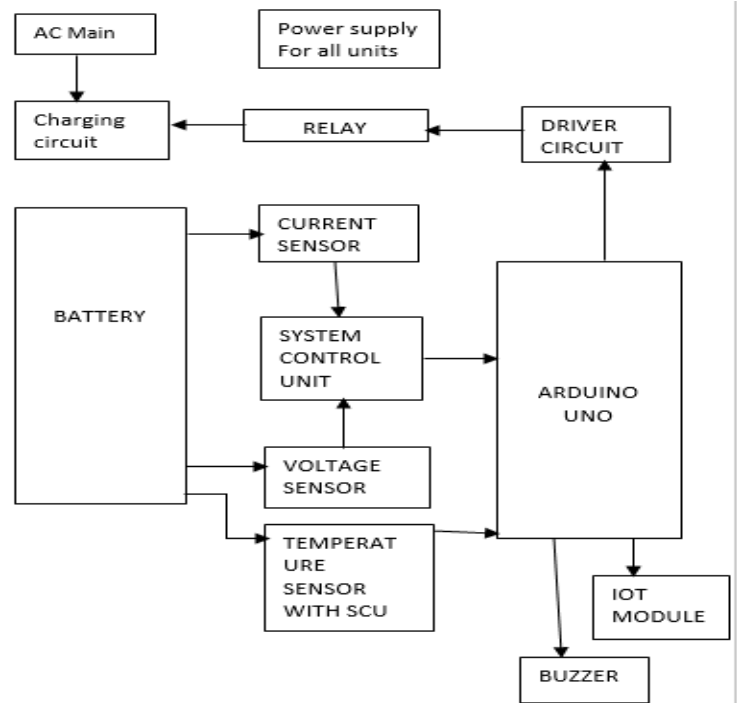

Fig – 1: Block Diagram.

3. BLOCK DIAGRAM DESCRIPTION

The above block diagram is a pictorial representation of our proposed work. An efficient fault detection system for battery in UPS using IoT and Arduino /ATMEGA 2560 is developed. This system uses an ACS712 sensor which is a current sensor to detect the current in system likewise LM35 Thermistor is used for the detection of the temperature. LM35 is a temperature sensor which also gives the voltage which is proportional to the temperature in centigrade. The current and the voltage sensor ACS712 is for both AC and DC current sensing in all systems like commercial, industrial etc.. This device works on the principle of Hall Effect. The data output from these sensors are stored and manipulated through Arduino. The State of charge (SoC) in the battery shows the amount of charge in the battery. The SoC depends on the various parameters like current, voltage and temperature.

Current sensor will be used to measure the load current and will also convert this current value into its proportional voltage levels control unit is the unit where the reference values and the present battery values are compared. The compared value is again fed to the Arduino as its input. Arduino will further process and operate the tripping coil in circuit breaker if input

value reaches the setting value. The present values are stored in the cloud using the Internet of Things. The buzzer is used to notify the customers. By doing so the life time of the battery can be extended.

4. CURRENT SENSOR

ACS712 provides economical and precise solutions for AC or DC current sensing in industrial, commercial, and communications systems. The device package allows for easy implementation by the customer. Typical applications include motor control, load detection and management, switched-mode power supplies, and overcurrent fault protection. The device consists of a precise, low-offset, linear Hall sensor circuit with a copper conduction path located near the surface of the die. Applied current flowing through this copper conduction path generates a magnetic field which is sensed by the integrated Hall IC and converted into a proportional voltage.

Device accuracy is optimized through the close proximity of the magnetic signal to the Hall transducer. A precise, proportional voltage is provided by the low-offset, chopper-stabilized BiCMOS Hall IC, which is programmed for accuracy after packaging. The output of the device has a positive slope ($>V_{IOUT}(Q)$) when an increasing current flows through the primary copper conduction path (from pins 1 and 2, to pins 3 and 4), which is the path used for current sensing.

The internal resistance of this conductive path is 1.2 mΩ typical, providing low power loss. The thickness of the copper conductor allows survival of the device upto 5× overcurrent conditions. The terminals of the conductive path are electrically isolated from the sensor leads (pins 5 through 8). This allows the ACS712 current sensor to be used in applications requiring electrical isolation without the use of opto-isolators or other costly isolation techniques.

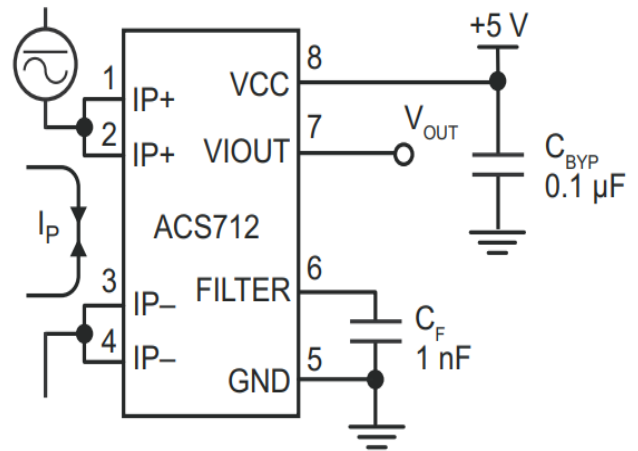
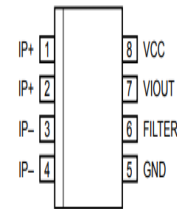

Fig 4.2 ACS 712 Connection

The ACS712 is provided in a small, surface mount SOIC8 package. The leadframe is plated with 100% matte tin, which is compatible with standard lead (Pb) free printed circuit board assembly processes. Internally, the device is Pb-free, except for flip-chip high-temperature Pb-based solder balls, currently exempt from RoHS.



Terminal List Table

Number	Name	Description
1 and 2	IP+	Terminals for current being sensed; fused internally
3 and 4	IP-	Terminals for current being sensed; fused internally
5	GND	Signal ground terminal
6	FILTER	Terminal for external capacitor that sets bandwidth
7	VIOUT	Analog output signal
8	VCC	Device power supply terminal

Fig 4.3 Pin Diagram ACS 712

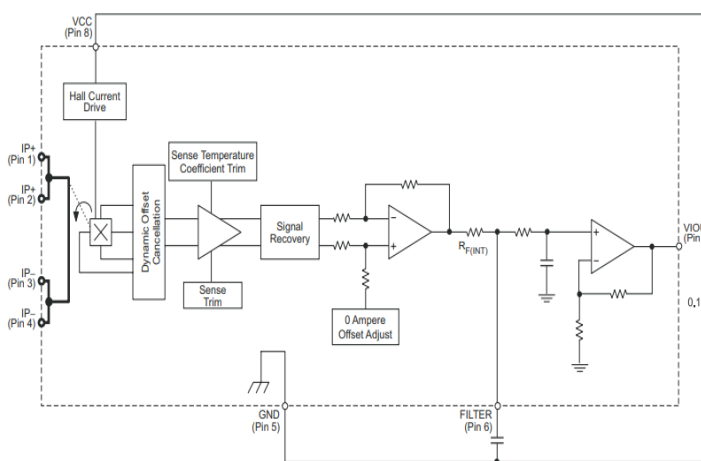

Fig 4.1 Functional Block Diagram

5. CHARGING CHARACTERISTICS OF BATTERY

Charging characteristics shows the time required to charge battery at specific current. Following table 3 shows these characteristics.

5.1 CURRENT SENSOR

The input given to this sensor is 5V. This sensor is placed in gap made in the Iron Dust core. Current carrying conductor is passed through the core, sensor shows the deflection. If the current is in positive direction, o/p vlg varies in between 2.5 to 5 V. Otherwise, it varies in between 0 to 2.5 V.

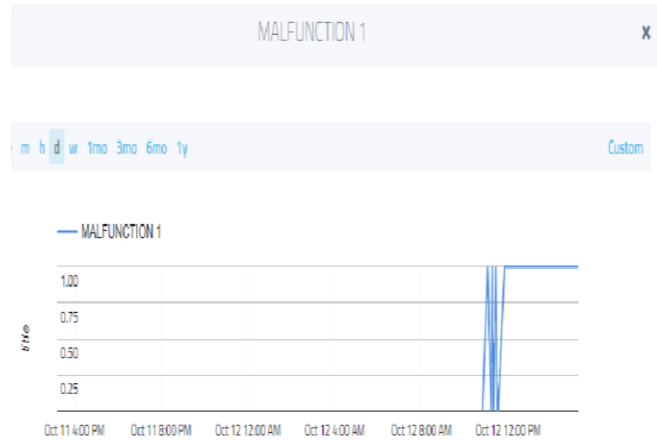
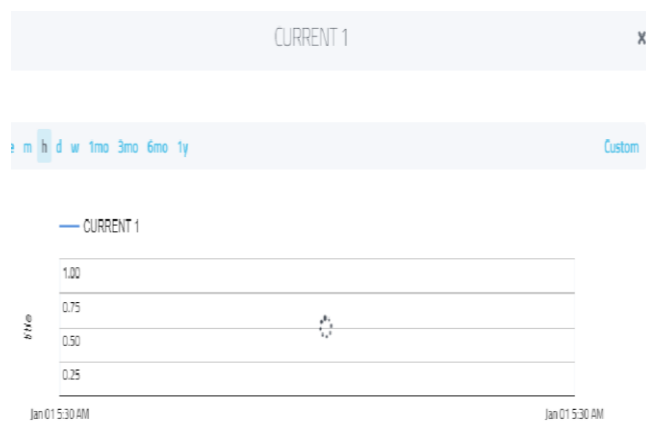

Fig 5.1 Current Sensor



- **BATTERY 1 VOLTAGE WITH RESPECT TO TIME**

It is the value for the measurement of battery voltage, if battery charge or discharge it needs to be monitored.



- **CURRENT GRAPH**

It monitors the ampere of the load. If battery is ON the dc fan will automatically ON. It will measure how much current is consumed through the graph.

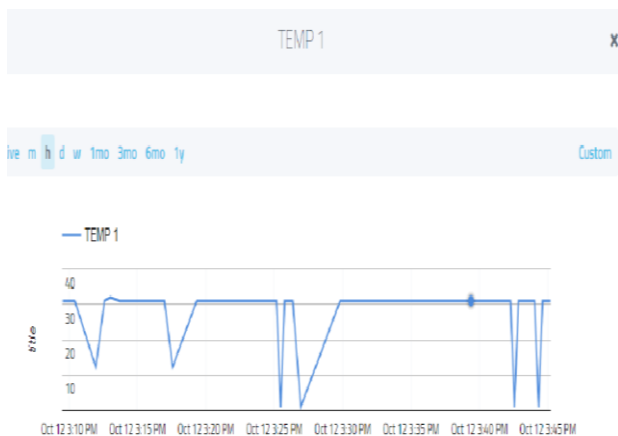

- **TEMPERATURE GRAPH**

This graph monitors the temperature of the battery, when the battery is suddenly charging and discharging the temperature will be increased in the battery. It will be monitored through the graph.

- **MALFUNCTION**

If the battery is not working correctly. It is used to find whether the battery is normal condition or abnormal condition.





ve m h d w 1mo 3mo 6mo 1y Custom



ve m h d w 1mo 3mo 6mo 1y Custom

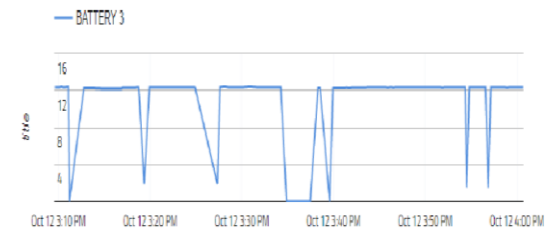

m h d w 1mo 3mo 6mo 1y Custom

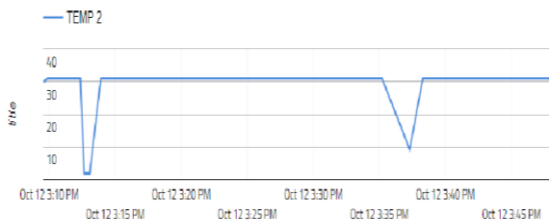

ve m h d w 1mo 3mo 6mo 1y Custom

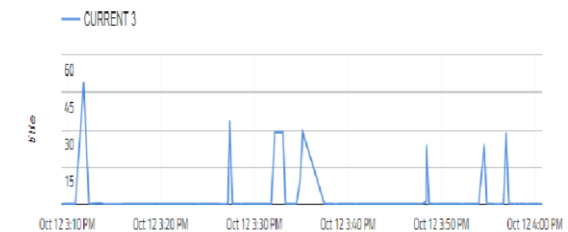

m h d w 1mo 3mo 6mo 1y Custom

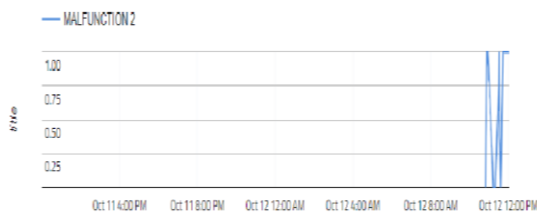

m h d w 1mo 3mo 6mo 1y Custom

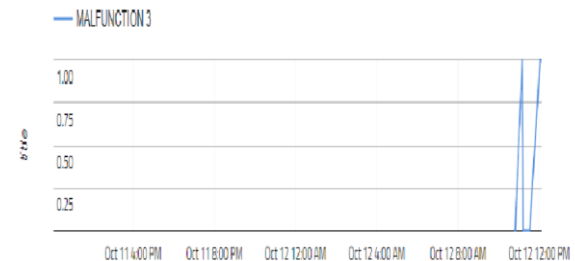

- **BATTERY 2 VOLTAGE WITH RESPECT TO TIME**

It is the value for the measurement of battery voltage.

- **CURRENT 2 GRAPH**

It monitors the ampere of the load.

- **TEMPERATURE 2 GRAPH**

This graph monitors the temperature of the battery.

- **MALFUNCTION**

If the battery is not working correctly.



Fig 5.2.1 Current Sensor

- BATTERY 3 VOLTAGE WITH RESPECT TO TIME**

It is the value for the measurement of battery voltage.

- CURRENT GRAPH**

It monitors the ampere of the load.

- TEMPERATURE GRAPH**

This graph monitors the temperature of the battery

- MALFUNCTION**

If the battery is not working correctly

Advantages

- Performance of Battery bank & their utilization can be assured with Remote monitoring of Single or Multiple Battery Banks - saves time
- Purchasing of Batteries / Cells through planned schedules, not emergency replacement
- Smarter battery management system can achieve a better efficiency and power at the same time
- The proposed system will help us to avoid regular site visits, prevent battery failure, extend battery life, reduce maintenance cost and increase safety.

Application

- Automotive industry
- Household application
- Industrial application

6. CONCLUSION

With the increasing awareness of global warming around the world, the demand for clean fuel/energy is on the rise and as a result there is a continuous shift towards the electric

vehicles (EVs) and hybrid electric vehicles (HEVs). Battery forms one of the most critical systems in any electric vehicle. Battery performance is influenced by factors such as depth of discharge (DoD), temperature and charging algorithm. EVs and HEVs use battery management system (BMS) to address the implementation of monitoring system parameters such as current, voltage and temperature. This paper attempts to provide a measurement of electrolyte temperature, electrolyte level and no of backup hours parameters of lead-acid batteries.

The experimental results for good battery and battery may lead to fail are shown in figure1. This tells the present status of each battery and displays the battery parameters. By using these results the user can know the present condition of battery and if the battery which may lead to fail tells the user that he/she has to remove that battery from the bank and replace with good battery. That removed battery internal resistance has to be checked manually and by this way he/she can determine the battery's operating life.

ACKNOWLEDGEMENT

We would like to thank our guide Dr. A. Karuppasamy, Professor of our department for guiding us to complete our project.

REFERENCES

- [1]. Yong Tian, Dong Li, Jindong Tian, "An optimal nonlinear observer for state-of-charge estimation of lithium-ion batteries", Industrial Electronics and Applications (ICIEA), 2017 12th IEEE Conference.
- [2]. C. Wu, J. L. Sun, C. B Zhu, Y. W. Ge, Y. P. Zhao, "Research on overcharge and overdischarge effect on Lithium-ion batteries", Proc. IEEE Veh. Power Propul. Conf., pp. 1-6, 2015.
- [3]. H. V. Venkatesetty and Y. U. Jeong, "Recent advances in lithium-ion and lithium-polymer batteries," in Proc. 17th Annu. Battery Conf. Applications and Advances, Jan. 2002, pp. 173-178.
- [4]. S. Nakano, Y. Goto, K. Yokosawa, K. Tsukada, "Hydrogen Gas Detection System Prototype with Wireless Sensor Networks", Digest Tech. Papers IEEE Sensors 2005, pp. 159-162, October 31-November 3, 2005.
- [5]. Fraiwan, L.; Lweesy, K.; Bani-Salma, A.; Mani, N. "A wireless home safety gas leakage detection system" in Proceedings of the 1st Middle East Conference on Biomedical Engineering (MECBME), Sharjah, United Arab Emirates, 21-24 February 2011; pp. 11-14.
- [6]. Szumanowski and Y. Chang, "Battery management system based on battery nonlinear dynamics modeling," IEEE Trans. Veh. Technol 2008, vol. 57, no. 3, pp. 1425-1432, May 2008.
- [7]. O. A. Mohamad, R. T. Hameed, N. Täapus, "Design and implementation of real time tracking system based on arduino intel galileo", Electronics Computers and

- Artificial Intelligence (ECAI) 2016 8th International Conference on, pp. 1-6, 2016.
- [8] Rasool Haaris, Rasool Aazim, Rasool Urfa, Raza Ali, Ahmad Waqar, "Centralized Environment and Battery Monitoring System for server rooms", Transportation Electrification Asia-Pacific (ITEC Asia-Pacific) 2014 IEEE Conference and Expo, pp. 1-5, Aug. 31 2014-Sept. 3 2014.
- [9] Atzori, L.; Iera, A.; Morabito, G. Understanding the Internet of Things: Definition, potentials, and societal role of a fast evolving paradigm. *Ad Hoc Netw.* 2017, 56, 122–140.
- [10] Back, J.A.; Tedesco, L.P.; Molz, R.F.; Nara, E.O.B. An embedded system approach for energy monitoring and analysis in industrial processes. *Energy* 2016, 115, 811–819.
- [11] Velandia, D.M.S.; Kaur, N.; Whittow, W.G.; Conway, P.P.; West, A.A. Towards industrial internet of things: Crankshaft monitoring, traceability and tracking using RFID. *Robot.Comput.Integr. Manuf.* 2016, 41, 66–77.
- [12] Xia, M.; Li, T.; Zhang, Y.; de Silva, C.W. Closed-loop design evolution of engineering system using condition monitoring through internet of things and cloud computing. *Comput.Netw.* 2016, 101, 5–18. [15] Qiu, T.; Zhao, A.; Ma, R.; Chang, V.; Liu, F.; Fu, Z. A task-efficient sink node based on embedded multi-core soC for Internet of Things. *Future Gener.Comput.Syst.* 2016. doi:10.1016/j.future.2016.12.024.
- [13] López-Benítez, M.; Drysdale, T.D.; Hadfield, S.; Maricar, M.I. Prototype for Multidisciplinary Research in the context of the Internet of Things. *J. Netw. Comput. Appl.* 2017, 78, 146–161.
- [14] Xia, Z.; Su, H.; Liu, T. Remote Monitoring System of Lead-Acid Battery Group Based on GPRS. In *Proceedings of the 2010 International Conference on Electrical and Control Engineering (ICECE)*, Wuhan, China, 25–27 June 2010; pp. 4023–4026.
- [15] Qiu, T.; Zhao, A.; Ma, R.; Chang, V.; Liu, F.; Fu, Z. A task-efficient sink node based on embedded multi-core soC for Internet of Things. *Future Gener.Comput.Syst.* 2016. doi:10.1016/j.future.2016.12.024.
- [16] López-Benítez, M.; Drysdale, T.D.; Hadfield, S.; Maricar, M.I. Prototype for Multidisciplinary Research in the context of the Internet of Things. *J. Netw. Comput. Appl.* 2017, 78, 146–161.
- [17] Xia, Z.; Su, H.; Liu, T. Remote Monitoring System of Lead-Acid Battery Group Based on GPRS. In *Proceedings of the 2010 International Conference on Electrical and Control Engineering (ICECE)*, Wuhan, China, 25–27 June 2010; pp. 4023–4026.
- [18] "Review Paper on Fault Detection for UPS System using GSM" by Anuradha.G.Deshmukh, Anuj B.Diggikar|JCSMC,vol 2,issue 12, December 2013,pg.344-349
- [19] D. Kastha, B. K. Bose, "Investigation of Fault Modes of Voltage-Fed Inverter System for Induction Motor Drive", *IEEE Transactions on Industry Applications*, vol. 30, n. 4, p. 1028-1038, July/August 1994.
- [20] K. Debebe, V. Rajagopalan, T.S. Sankar, "Expert Systems for Fault Diagnosis of VSI AC Drives", *IEEE Industry Applications Society Annual Meeting*, vol. 1, p. 368-373, 1991.
- [21] J. Breckling, Ed., *The Analysis of Directional Time Series: Applications to Wind Speed and Direction*, ser. *Lecture Notes in Statistics*. Berlin, Germany: Springer, 1989, vol. 61.
- [22] Design of automatic weather station based on GSM module Author(s) Xingang Guo Dept. of Electron. & Inf. Eng., ChangChun Univ. of Technol., Changchun, China Yu Song IV. Published in: *Computer, Mechatronics, Control and Electronic Engineering (CMCE)*, 2010 International Conference on (Volume:5) Date of Conference: 24-26 Aug. 2010
- [23] "Fault Acknowledgement System for UPS using GSM", Aniruddha Dekate¹, Pradip Ramchaware² Electronics And Telecommunication, Amaravti University, Akola, India. *International Journal of Scientific and Research Publications*, Volume 5, Issue 5, May 2015.
- [24] Becker, J.; Lelie, M.; Jansen, M.; Sauer, D.U. Impact of low Temperatures on Performance and Ageing of Lithium-ion Batteries and Strategies for Heating. In *Proceedings of the 11th Symposium on Hybrid and Electric Vehicles*, Braunschweig, Germany, 18–19 February 2014.