

Driver Safety System by Drowsiness Detection using MATLAB

▪ Authors Name/s = Mr. Ratnesh kumar , Ms. Saumya Chaturvedi , Mr. Saurabh singh

▪ Dept. name = Computer Science and Engineering(CSE)

▪ Collage Name = Galgotias University

▪ Greater Noida , India

Abstract— Life is urgent and it is brimming with hazard. Subsequently, security precautionary measure ought to consistently be taken before any sort of disaster writing happens. Street mishap is one of the significant reasons forever frailty in now days. Each and every second is significant or critical to fare thee well while driving. Single minute inconsiderateness can cause lifetime lament. The vast majority of the investigations state that the greater part of the street mishaps happens because of lack of regard and latency of the driver. Drowsiness Detection System has been created, utilizing a machine vision based ideas. The framework utilizes a little camera that focuses legitimately towards the driver's face and screens the driver's eyes so as to distinguish exhaustion or drowsiness. For a situation if weariness is identified, an admonition signs or caution signal is given to make the driver aware of wake up and leave the tired state. As a matter of first importance, the framework recognizes the face and afterward the eyes, and afterward decides if the eyes are open or shut.

Keywords— *Drowsiness Detection; Safety; Driver Safety; Filter; MATLAB; Image Processing*

1. INTRODUCTION

When in doubt a large portion of the people doesn't hold fast to any of the above law and it is amazingly inconvenient in any occasion, for a traffic Police authority to rebuff the driver with any of the above law. [1]-[3] And this is the spot development comes in, there have been a lot of devices that were devised far and wide to diminish this explanation anyway most of them are super costly or not available in the local exhibit. [4] Driver languor discovery is a vehicle prosperity advancement which hinders disasters when the driver is getting worn out. [5] Various assessments have prescribed that around 20% of all road disasters are exhaustion related, up to half on explicit avenues. Driver shortcoming is a basic factor in a gigantic number of vehicle setbacks. [6] Recent estimations check that consistently 1,200 passing's and 76,000 injuries can be attributed to shortcoming related mishaps. The improvement of advances for distinguishing or preventing tiredness in the driver's seat is a critical test in the field of disaster avoidance systems. [7]

Because of the danger that sluggishness presents all over the place, methods ought to be made for killing its belongings. [8] Driver in thought might be the eventual outcome of a nonattendance of sharpness when driving in

view of driver sluggishness and interference. Driver interference happens when a thing or event shields an individual from seeing the driving endeavor. [9] Unlike driver interference, driver tiredness incorporates no initiating event simultaneously, rather, is depicted by a unique withdrawal of thought from the road and traffic demands. Both driver sluggishness and interference, in any case, may have comparable effects, i.e., reduced driving execution, longer reaction time, and an extended peril of crash incorporation. Taking into account Acquisition of video from the camera that is before driver perform consistent preparing of a moving toward video stream to incite the driver's level of fatigue if the laziness is Estimated, by then the yield is send to the ready system and alert is started. [10]

The point of this investigation is to deliver an answer for one of the significant reasons for the street mishap, the driver laziness; the proposed arrangement tracks the driver's eyes and afterward tell him when his eyes get shut so as to abstain from losing the control of the vehicle and causing car crashes.

In a vehicle security innovation, driver drowsiness discovery [1-3] is basic to forestall street mishaps. These days the vast majority of the individuals utilizing cars, there is an expansion in street mishaps too. Driver sluggishness is likewise an explanation behind a portion of the street mishaps. Today the significant test is recognizing Driver sleepiness and cautioning with an alert.

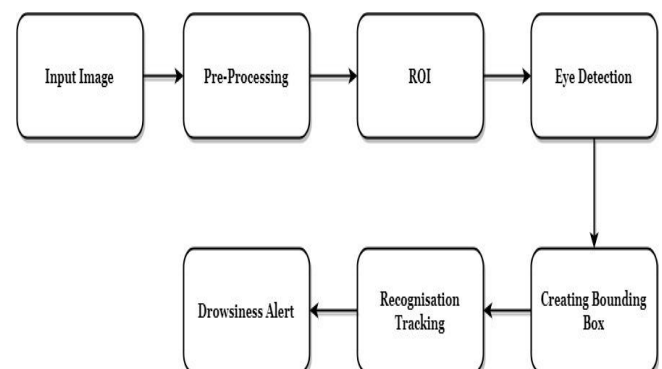

Fig. 1. Typical Drowsiness Detection System

This paper, talks about a framework that utilizes PC vision and picture handling to control the harm brought about by the above expressed marvel.

Drowsiness detection system as shown in fig 1, firstly image is acquired using camera, preprocessing has noise removal steps and, ROI means region of interest checking that is

eyes. Then eye part is segmented, and checked if it is closed or open, bounded by a box, after recognition Drowsiness alert is sent. By utilizing a non-nosy machine vision based concepts, sleepiness of the driver distinguished framework is created. Many existing frameworks require a camera which is introduced before driver [4]. It focuses straight towards the substance of the driver and screens the driver's eyes so as to distinguish the languor. For enormous vehicle, for example, substantial trucks and transports this game plan isn't relevant. Transport has an enormous front glass window to have an expansive view for safe driving. In the event that we place a camera on the window of front glass, the camera obstructs the frontal view of driver so it isn't useful. On the off chance that the camera is put on the casing which is just about the window, at that point the camera can't keep the front perspective on the essence of the driver accurately. The improvement of sleepiness recognition innovations is both a modern and scholarly test. In the car business, Volvo built up the Driver Alert Control which cautions drivers associated with lazy driving by utilizing a vehicle-mounted camera associated with its path takeoff cautioning framework. Following a comparable vein, an Attention Assist System has been created and presented by Mercedes-Benz that gathers information drawn from a driver's driving examples relentlessly discovers if they got data connects with the controlling development and the driving condition close by. The driver tiredness recognition framework, provided by Bosch, takes choices dependent on information got from the sensor positioned at the guiding, the vehicles' driving speed, blinker use, and the path help camera mounted at the front of the vehicle.

2. LITERATURE REVIEW

There are different looks into on this theme. Most of the exploration depends on vision based technique. It incorporates following driver's eyes by distinguishing eyes conclusion state to recognize driver's drowsiness conditions. Eye following technique is finished by utilizing different strategies like layout coordinating, eye squinting identification. A portion of the methodologies incorporate watching driver's conduct by utilizing physiological methodologies like watching brain activities utilizing sensor. It incorporates utilization of terminals to distinguish electric sign from driver's skin. This methodology is utilized for checking driver's wellbeing and eye flickering identification. Another methodology incorporates utilization of bio signs and dynamic Bayesian system to distinguish driver weariness through various sensors. Various methodologies use different strategies to recognize driver drowsiness: histogram based technique to extricate eye shape, skin shading extraction and eyes extraction strategy utilizing car learning and molecule separating calculation. Another methodology depends on the driving conduct. It incorporates guiding movement based observing that is when directing is still for certain divisions of time then it helps to distinguish lazy condition. Right now is cautioned utilizing steering vibration. But

these methodologies do not give exactness to distinguishing driver weariness. In spite of the fact that Electrode ECG, EEG strategies provide accuracy for driver wellbeing observing and eye squinting identification, they are costly and irritating as it expect cathode to be in contact with driver's skin. This framework gives arrangement by eye flicker location technique. Utilizing cell phone which makes the framework savvy and effective.

Convolutional Neural Networks (CNNs) techniques have to a great extent created a freakish presentation in the languor recognizing zone and are additionally a ground-breaking help to different arrangement assignments. Introducing these calculations to viable applications on implanted systems is still oppressive since the model size is commonly huge and requires a significant level of computational intricacy.

The strategies of tiredness/exhaustion discovery can be extensively characterized into three significant classifications: Physiological measures, roundabout vehicle conduct and legitimately perceptible visual behaviors [4], [5]. The best recognition exact methods depend on physiological marvels like mind waves, pulse, beat rate and breath. These systems are meddlesome, since they have to connect a few anodes to the drivers, causing irritation to them. Some agent extends right now the MIT Smart Car [6], and the ASV (Advanced Safety Vehicle) venture performed by Toyota, Nissan [7]. The electroencephalographic (EEG) calculation, which is a physiological drowsiness measure, has been concentrated to recognize sleepiness also. The greater part of these examinations have utilized EEG to approve the presence of languor when different measures are being assessed instead of as an exhaustion discovery measure [8], [9].

The present proposed strategy dependent on two fundamental stages, the main stage is to distinguish and pre-process the eye pictures utilizing the picture handling system and the subsequent stage is to assemble a grouping model that will have the option to characterize whether the eye is opened or shut and afterward start an alert in like manner.

The most significant worth this exploration has added to the writing right now to locate the least difficult and most proficient way to deal with take care of the programmed languor recognition issue; utilizing easiest methodology so as to use this framework in the constant circumstance, so the handling time will be limited.

3. IMPLEMENTATION

The technique depends on the Viola-Jones calculation. The task began with distinguishing the eyes of a static image put away in the PC. The initial step included putting away the image in a variable referencing the area and the

kind of image. From the given image, just the eyes are segmented out and handled to identify for conclusion or exhaustion. The image is handled distinctly to distinguish the eye locale of the image by giving the position, width and tallness of the area as contributions to the square shape() work. The position, width and tallness are gotten by utilizing the Vision class in MATLAB. The inherent item identifier work CascadeObjectDetector is utilized to identify the eyes. The Eye Detect object is given as contribution to the progression work alongside the image and the qualities returned compare to the X-Coordinate, Y Coordinate, Width and Height of the eye district. The image is then edited utilizing the small scale() work with one contribution as the n*4 network and the other being simply the image. The RGB image in this manner acquired is first changed over to its proportionate grayscale structure utilizing the rgb2gray() work. This is trailed by changing over the along these lines acquired dark scale image to its highly contrasting structure utilizing the im2bw() work. The BW image along these lines acquired is then enlarged to get just the eyes. The motivation behind playing out the enlargement work is to improve the closer view highlights. $IM2=imdilate(IM,SE)$ widens the grayscale, paired, or stuffed double image IM, restoring the expanded image, IM2. SE is an organizing component article, or exhibit of organizing component objects, returned by the STREL work. The fundamental impact of the administrator on a parallel image is to bit by bit extend the limits of areas of forefront pixels (white pixels). Therefore, Sleep Detection System Using MATLAB Image Processing zones of frontal area pixels develop in size while openings inside those areas become little. In Fig.1 algorithm for drowsiness detection is shown.

For recognizing the face, since the camera is centered around the vehicle driver, we can abstain from processing the image at the corners along these lines diminishing a lot of processing required. When the district of intrigue is characterized face has been recognized, the locale of intrigue is presently the face, as the following stage includes identifying eyes. To identify the eyes, rather than processing the whole face district, we mark an area of enthusiasm inside the face locale which further aides in accomplishing the essential objective of the proposed framework. Next we utilize Viola Jones calculation for eye detection, and recognize the eyes by processing just the locale of intrigue. When the eyes have been identified, the following stage is to decide if the eyes are in open/shut state, which is accomplished by extricating and analyzing the pixel esteems from the eye district. In the event that the eyes are distinguished to be open, no move is made. Be that as it may, if eyes are distinguished to be shut consistently for two seconds, that is a specific number of casings relying upon the edge rate, at that point it implies that the vehicle driver is feeling lazy and an admonition signal is produced. In any case, in the event that the shut conditions of the eyes are not ceaseless, at that point it is proclaimed as a squint.

4. Methodology

There has been a great deal of approaches in the recognition of sluggishness. The parameters thought about were the enlightening window, the quantity of squints

during a timespan, no. of yawns and so forth there are around 12 facial highlights that can be controlled by the camera mounted on the circuit board. The parameter considered here is just the window of educational. Notwithstanding the 12 parameters, the head movement was likewise mulled over which, thus, added to the improvement of the exactness of the measurement. Driver Drowsiness is one of the genuine explanations behind accidents on the planet.

Right now identify the dozing whole face locale may not be required however just eye district is sufficient for distinguishing sleep. At initial step by utilizing viola-jones face recognition calculation face was identified from the pictures. When the face was recognized, a similar viola-jones face location calculation was utilized to remove the eye region from the face images. In 2001 P Viola and M Jones built up the Viola-Jones object discovery calculation [10-15], it is the principal calculation utilized for face recognition. For the face identification the Viola-Jones calculation having three methods those are Haar-like highlights, Ad a lift and Cascade classifier. In this work, Viola-Jones object location calculation with haar course classifier was utilized and executed utilizing MATLAB.

The methodology algorithm is presented in fig 2, the camera is initialized in first step, the frames are taken as images, then face is detected using viola jones method. After taking the face samples eyes are detected and marked using bounding box. The method used for eye detection is viola jones method. Eyes are tested if are closed for 10 seconds together, drowsiness is detected and alerted using the hardware system.

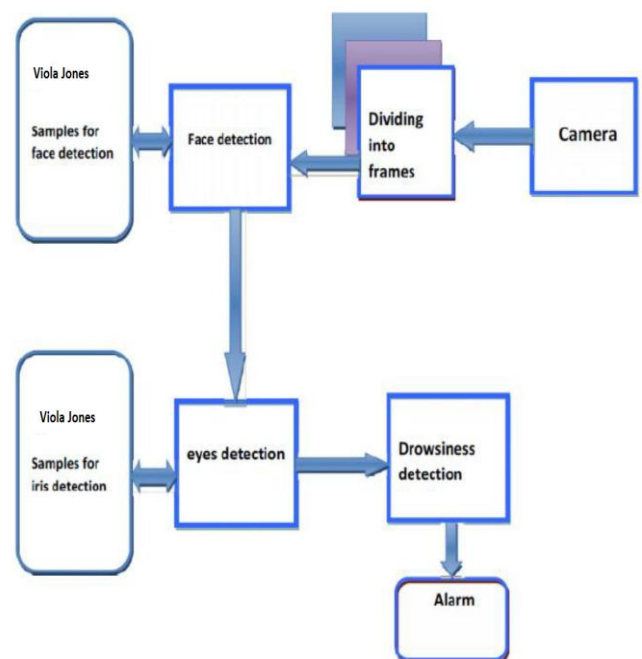

Fig. 2. Algorithm for Drowsiness Detection

Viola-Jones [9] calculation isn't just altogether utilized in face identification, however is as valuable for facial component extraction, for our situation identifying the eye

divide. At first MATLAB was utilized to extricate the eye divide in a face utilizing the EYEPAIRBIG work [10]. The part of eyes was effectively recognized yet we additionally required both the eyes distinguished independently. Much after rehashed runs we couldn't get our ideal outcomes. Here and there the eyes were not recognized independently, now and again any dark spot in a picture was distinguished as eyes. Hence it was inferred that even while being one of the most much of the time utilized calculation for face recognition, these calculations couldn't accumulate the outcomes we needed for our figurings. It was then that we structured another calculation for eye location to fill our need altogether.

The Algorithm in this way structured was named as cropper calculation. The name along these lines given was based on the way that this calculation played out our important editing in a picture.

Driver sleepiness is the most basic reason for car crashes, in this manner sluggishness identification assume an essential job in forestalling car crashes. By building up a programmed answer for cautioning drivers of drowsing, before a mishap happens, this could lessen the quantity of auto collisions. Thusly, this examination proposes a continuous recognition approach for driver languor. The proposed approach has two stages: picture preparing and AI. The job of picture handling stage is to perceive the essence of the driver and afterward removes the picture of the eyes of the driver. This stage utilizes Haar face location calculation that takes caught edges of picture as information and afterward the identified face as yield. Next, Haar is likewise used to separate the eyes picture from the distinguished face which will be utilized as a contribution for the AI stage. The primary job of the AI is to group either the eyes of the driver are shut or opened utilizing Support Vector Machine (SVM). On the off chance that the consequence of the grouping demonstrates that the driver's eyes is shut for a predefined timeframe, the eyes of the driver will be viewed as shut and subsequently a caution will be begun to alarm the driver. The proposed system has been tried on accessible benchmark information. The outcome exhibits the precision and strength of the hybridized of picture preparing strategy with AI system. Consequently, it very well may be reasoned that the proposed approach is a compelling arrangement technique for a constant of driver tiredness discovery.

5. RESULTS

In this section, results are shown in fig. 3 and fig. 4, in fig. 3 the detection of eyeball is not seen, which will trigger the circuit in fig. 4 to produce a buzzing sound which will wake up the driver.

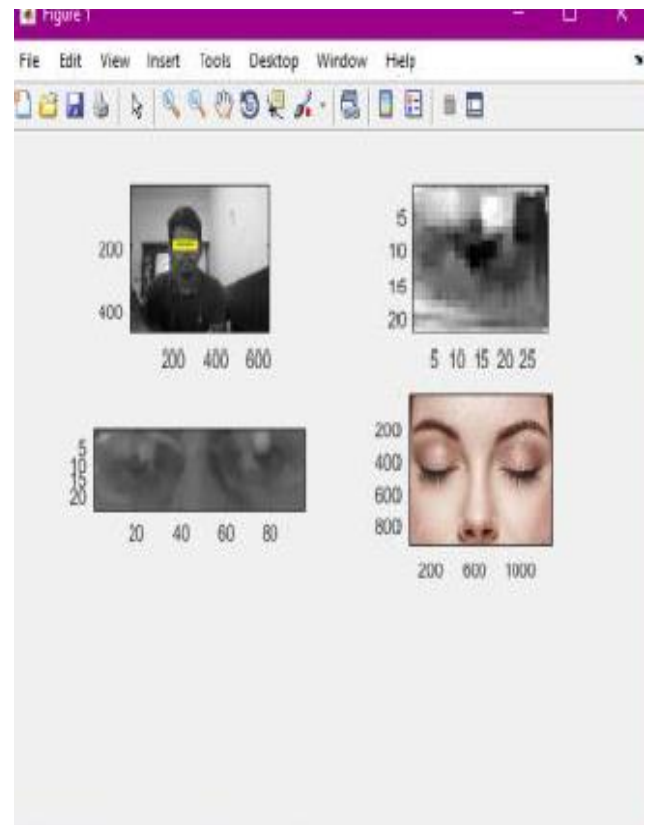
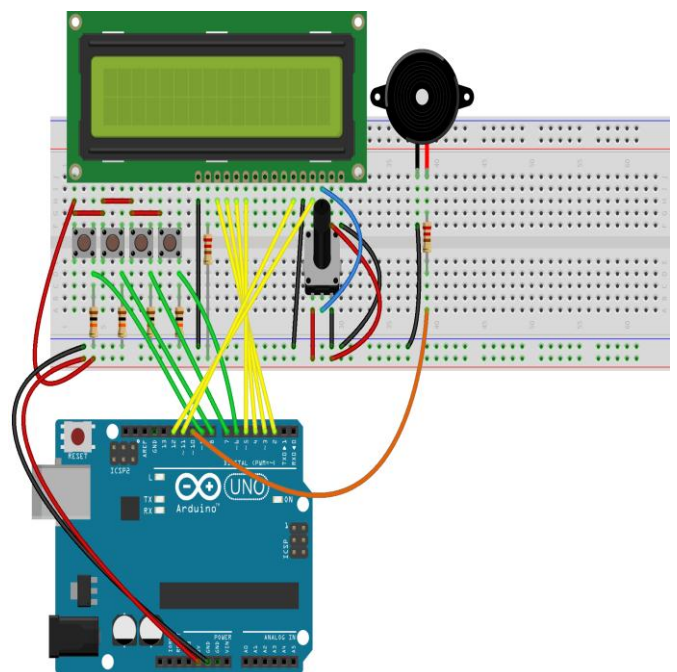

Fig. 3 Output Drowsiness Detection



fritzing

Fig. 4. Circuit Diagram

6. CONCLUSION

Rather than limit drowsiness level it is proposed to structure a ceaseless scale driver weakness detection framework. It screens the degree of drowsiness ceaselessly

and when this level surpasses a specific worth a sign is produced which controls the water powered slowing mechanism of the vehicle. In this way we built up an arrangement of hostile to mishap dependent on languid driving detection and attempts to take a gander at the rising advances and decide the best methodologies in attempting to forestall the main source of deadly vehicle crashes. As of now, the main selling item in the market is just a reed change to identify head edge tilt. Accessible item is incredibly constrained and not extremely compelling.

REFERENCES

- [1] M. Yauri-Machaca, B. M.-C. N. V.-C. a. A. R.-G., 2018. Design of a Vehicle Driver Drowsiness Detection System Through Image Processing using Matlab. San Salvador, IEEE 38th Central America and Panama Convention (CONCAPAN XXXVIII). DOI: 10.1109/CONCAPAN.2018.8596513
- [2] Xu, W. C. a. Y., 2013. Real-Time Driver Gaze Direction Detection Using the 3D Triangle Model and Neural Networks. 7th Asia Modelling Symposium, pp. 41-45.
- [3] Jain, A. K., 2018. Working model of Self-driving car using Convolutional Neural Network, Raspberry Pi and Arduino. Coimbatore, India, 2018 Second International Conference on Electronics, Communication and Aerospace Technology (ICECA). DOI: 10.1109/ICECA.2018.8474620
- [4] Manu, B. N., 2016. Facial features monitoring for real time drowsiness detection. 12th International Conference on Innovations in Information Technology (IIT), pp. 1-4.
- [5] H. Singh, J. S. B. a. J. K., 2011. Eye tracking based driver fatigue monitoring and warning system. India International Conference on Power Electronics 2010 (IICPE2010), pp. 1-6.
- [6] Iridiastadi, V. T. a. H., 2017. Challenges in detecting drowsiness based on driver's behavior. s.l., IOP Conference Series: Materials Science and Engineering. DOI: 10.1088/1757-899X/277/1/012042
- [7] X. Ma, L. C. a. K., 2017. Depth video-based two-stream convolutional neural networks for driver fatigue detection. Singapore, 2017 International Conference on Orange Technologies (ICOT). DOI: 10.1109/ICOT.2017.8336111
- [8] AntoinePicot,SylvieCharbonnier,"On-Line Detection of Drowsiness Using Brain and Visual Information",IEEE Transaction on systems, man and cybernetics part a: systems and humans, VOL. 42, NO. 3,2012
- [9] Boon-Giin Lee and Wan-Young Chung, "Driver Alertness Monitoring Using Fusion of Facial Features and Bio-Signals", (IEEE) Sensors journal, vol. 12, no. 7,2012
- [10] Ralph OyiniMbouna, SeongG. Kong, Senior Member, "Visual Analysis of Eye State and Head Pose for Driver AlertnessMonitoring",IEEE transactions on intelligent transportation systems, VOL. 14, NO. 3 2013
- [11] S. Vitabile, A. D. Paola and F. Sorbello, "A real-time nonintrusive FPGA-based drowsiness detection system", Journal of Ambient Intelligence and Humanized Computing, Volume 2, Issue 4, pp 251-262, December 2011.
- [12] Road safety information, rospa, "driver fatigue and road accidents",www.rospa.com, 2011
- [13] Arun Sahayadhas,Kenneth Sundaraj,"Detecting Driver Drowsiness Based on Sensors A Review",pp.16937-16953, ISSN 1424-8220, Malaysia 2012
- [14] Drowsy Driving, Facts and Stats: Drowsy Driving -Stay Alert, Arrive Alive. <http://drowsydriving.org/about/facts-and-stats/>, 2016.
- [15] J. Qiang and X. Yang, "Real-time eye, gaze, and face pose tracking for monitoring driver vigilance," International Journalof Real-Time Imaging, vol. 8, 2002, pp. 357-377, doi:10.1006/rtim.2002.0279