

Study of Manufacturing of Hydraulic Cylinder Rod

Sadiq sha H A J¹, Geethanjali K.S²

¹Student, Department of Mechanical Engineering, Gitam deemed to be University, Nagadenahalli, Bangalore 561203, India

²Assistant professor, Department of Mechanical Engineering, Gitam deemed to be University, Nagadenahalli, Bangalore 561203, India

Abstract - This Paper represents the various methods and process involved in manufacturing of Hydraulic Cylinder rod for different application. To manufacture Hydraulic Cylinder rod we have selected C45 as a raw material. To strengthen and to make material smoother C45 undergoes some process like preheating at 400°C Post heating at 500°C Quenching (Q) with coolant and Tempering (T) at 900°C. After each and every process Quality check process is implemented to check respective parameters. Straightening of rod is made to remove blandness' which occur during Q and T process. Also Ball peeling is done to remove surface imperfection. After this Rods are cut into required diameter and length dimension given by the operators. Later we have to do some modification on the rod that is creating a slot using slot milling with defined parameter. Induction hardening is done get surface harder. Cylindrical grinding is carried out to get cylindrical surface. Frictionless welding is used to join rod and the created slot. A very well programmed robotic polishing is used to get high accuracy surface finish. Electro plating is carried out to avoid rusting with this all the process have completed. Once Quality check is over final product is ready for future application like construction and earthmoving, lifting/utility, truck hydraulic, forestry, mining, underground haulers and loaders, surface drill rigs, Excavator (Mini, Midi) etc.

Key Words: Bar peeling, cylindrical grinding, Electron plating, Friction Welding, Induction Hardening, Quenching and Tempering, Raw Material, Robotic polishing, Slot Milling, Thread Rolling.

1. INTRODUCTION

Manufacturing of hydraulic cylinder rod is explain about the various methods and process that are involved in the process of manufacturing. In this process of manufacturing material under goes in to varies method like raw material, quenching and tempering, rod straighten, Bar peeling, material cutting, slot milling, etc. hydraulic cylinder rod is one of the most important in excavator it was connected to the bucket and hydraulic cylinder it contain hydraulic fluid

while applied a pressure the hydraulic cylinder rod move up due to the bucket moves. The Wipro is one of the best company for manufacturing of excavators.

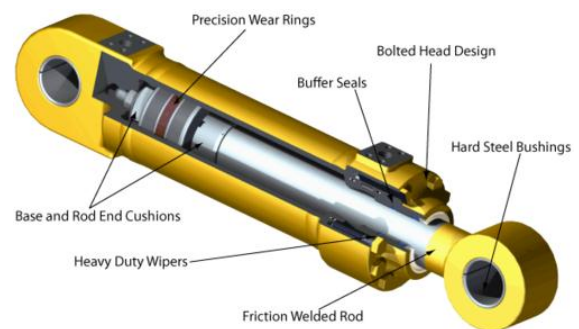

Fig-1: Diagram of hydraulic cylinder rod

2. METHODOLOGY

In this process of manufacturing of hydraulic cylinder rod there are several methods as give below.

3. Raw material

In this manufacturing process raw material is used C45 (medium carbon steel). After getting of raw material it will be send to Quenching and Tempering.

4. Quenching and Tempering

In this process there are four steps are involved.

4.1. Pre-heating

In this process the rod of raw material is heated up to 400 Degrees in two chambers.

1. Pre heating 1
2. Pre heating 2

4.2. Post-heating

In this process the rod of raw material is heated up to 500 Degrees in two chambers.

1. post-heating 1
2. post-heating 2

4.3. Quenching

In this process material is under go to quenching and coolant oil is sprayed on the rod to reduce the temperature of material. The coolant used is motule

4.4. Tempering

After cooling the material in quenching process again reheating take place at 900 degrees to make material strong and hard.

Table-1: Quenching and Tempering Parameters.

Q AND T PARAMETERS FOR C45

DIAMETER (C45)	COIL SELECTION	PRE-HEATING	POST-HEATING	CURING TEM	TEMPERING POWER	TEMPERING TEMP	FEED (M/M)
43-44	5DIA 63	53%	52%	890	29%	650	2036
47-48	5 DIA 63	49.50%	42%	880	12%	650	1808
50-53	5 DIA 63	47%	35%	880	31%	650	1500
53-55	5 DIA 63	47%	35%	880	28.50%	650	1425
55-60	5 DIA63	40%	37%	880	28%	850	1205
62-65	5DIA63	60%	50%	880	37%	850	1360
67-68	5DIA63	41%	54%	880	49%	850	817



Fig-2: Show the process of preheating, post heating, quenching and tempering.

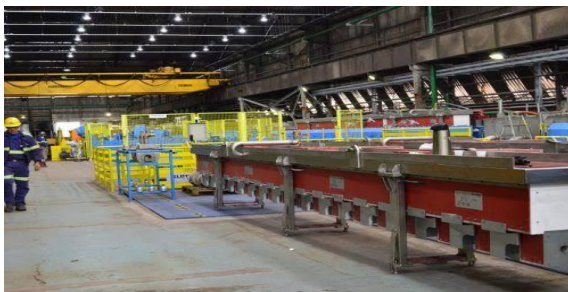

Fig-3: Show that after Q and T material rods are kept In storage for cooling

Table-2: Quality Chuck Parameters.

INSPECTION ANF CONTROL PLAN

CHARACTOR	INSTRUMENTS	LEAST COUNT	REMARK	FEED
POST CUTTING TEM	PYROMETER	1 DEG	RECORD	100%
TEMPERING TEMPERATURE	PYROMETER	1 DEG	RECORD	100%
QUENCH CONCENTRATION	RETRACAO METER	0.2%	RECORD AT H	ONCE IN SHIFT
QUENCH FLOW	FLOW SENSOR	2000L/MIN	RECORD AT H	ONCE IN SHIFT
QUENCH TEMPERATUER	SYSTEM	1 DEG	RECORD	100%

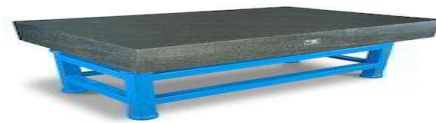

Fig-6: Black granite surface plate mitutoyo is used. For quality chuck of rod.

5.Bar peeling

In the process of bar peeling the material rod is send to machine because after hot rolling process from Q and T. The rod contain cracks after cooling process. On the metal oxide layer is formed. Inadequacy we have to remove metal oxide layer that was formed and raw material should proceed for further processing.



Fig-3: Show the bar peeling process.

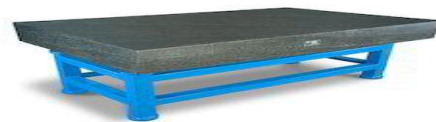

Fig-4.Black granite surface plate mitutoyo is used.For quality chuck of rod.

6. Rod Straitening

After bar peeling rod will occur bends and dents. So due to this bends should be removed in this process. Rod is send in this machine and pressure is applied on it and remove of bend will take place.



Fig-5: Show the rod straightening process.

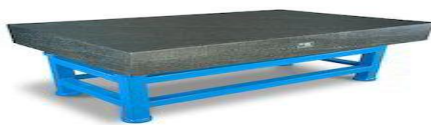

Fig-6: Black granite surface plate mitutoyo is used. For quality chuck of rod.

7. Material Cutting

In this process different size and measurement are given to an operator. And quality maintenance done with vernier calliper. While cutting of material.



Fig-7: Show material cutting machine.



Fig-8: show that vernier calliper is used to quality chuck the length.

8. Slot Milling

After material cutting the rod is send to slot milling. Speed of milling is 412 RPM. The feed given in milling is 0.3 (mm/rev). Slot milling is the process that making a groove in one end side of the rod to hold the material for electro plating process.

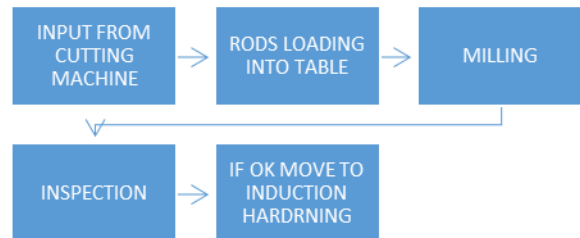

Fig-9: Flow chat show the process of slot milling.

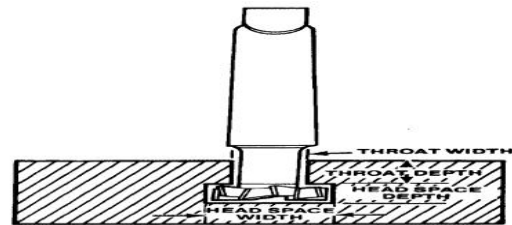

Fig-10: show the slot milling of rod.

Table-3: Parameters of Slot Milling.

SLOT MILLING PARAMETERS

S.NO	DIMENSION	INSTRUMENT	L.C
DISTANCE	16+1,16-1	VERNIER	0.02MM
WIDTH	13+1,13-1	VERNIER	0.02MM
DEPTH	0+0.7	VERNIER	0.02MM

9. Induction Hardening

Induction heating is a process which to bond of soft metals and hard metal in induction heating it has temperature of 900 degrees. Induction heating has high efficiency, high reliability.

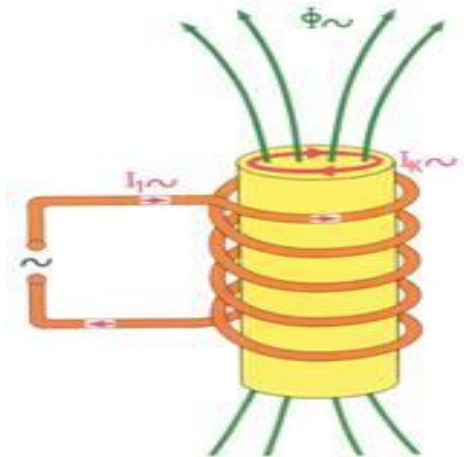

Fig-11: Diagram of induction hardening.

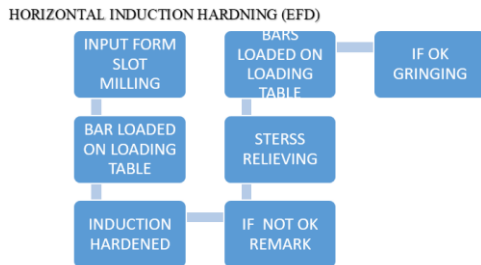

Fig-12:Flow chat show the process induction hardening.



Fig-13: show the machine of induction hardening.

Table-4: Parameters of Induction Hardening.

s.no	diameter	instrument	L.C
HARD ZONE	L+2,L-2	TAPE	1MM
SOFT ZONE	L+2,L-2	TAPE	1MM
HARD NESS	AS PER SCALE	PORTABLE HARDNESS TESTER	0.1 HRC
BOND /STRAIGHTNESS	AS PER SCALE	FEELER GAUGE	0.05MM
Q AND T HARDENING	23-38 DEGREE	SYSTEM DISPLAY	

10. Cylindrical Grinding

The cylindrical grinding machine is used generally for producing external cylindrical surface .The machine is very similar to a center lathe.[3] Typical movement in a cylindrical grinding .the grinding wheel is located similar to

the tool post, with an independent power driven at high speed, suitable for grinding operation.[4]both the work and grinding wheel rotate counterclockwise. The work that is normally held between centers is rotated at much lower speed compare to that of at the grinding wheel.

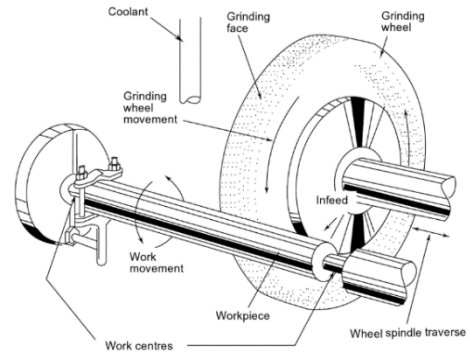

Fig-14: Show the gringing machine.



Fig-15: show the thickness of rod is measurd by mitutoyo 7301 thickness gauge is used to quality chuck

11. Friction Welding

Process of friction welding depend on friction in this welding process, the friction is used to produce heat at the interference surface. This heat is further used to join two work pieces by applying external pressure at the surface of work piece. In this welding process, it is normally 800-1200 degree centigrade for steel. After this heating phase, a uniformly increasing pressure force applied until the both metal work pieces makes a permanent joint. The spindle speed is 500 in the machine.as the rod diameter increases the timing of operation will increased. [2]



Fig-16: show the welding due to friction.

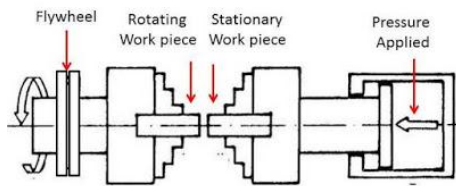

Fig-17: show the welding process.

Table-5: parametes of friction welding.

DIA	40	45	50	60
SPINDLE SPEED	500	500	500	500
SOFT FORCE(T)	2	2	2	2
FRICTION FORCE	12	13	12	12
FRICTION BURNOFF DISPLACE	5.8	6.5	7.2	7.3
UPSET FORCE	17.5	33	27.5	40
UPSET TIME	8	10	10	14
INPUT JOB TOLERANCE	1	1	1	1

12.Thread Rolling

In this process different types of thread are used like sharp v, unified, Whitworth, modified square 10 degree included angle, acme, B and s worm, modified buttress, knuckle, Dardelet.

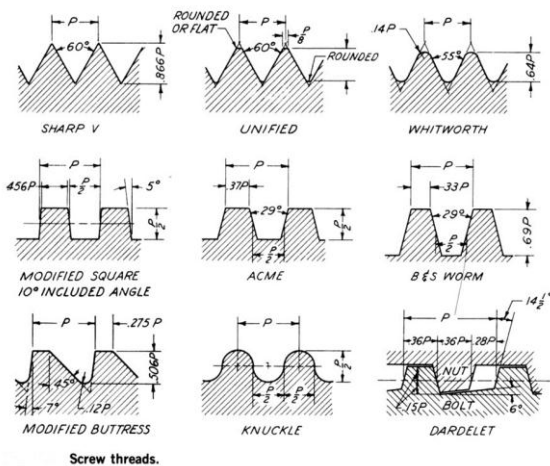

Fig-18:show the different thread types.

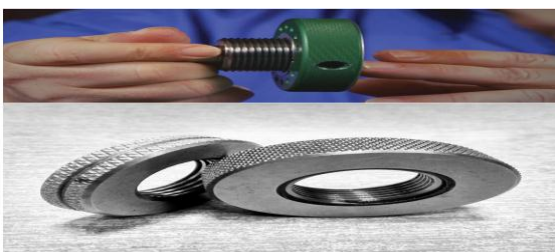

Fig-19.show the ring gauges that are used to measure threading as quality chuck.

13. Robotic Polishing

Robotic polishing is the process of perfect until they are in smooth. Polishing robots are programmed to apply just the right amount of pressure and it give high quality.it moderate the waste age of raw material.it save time and money. The accuracy of robot polishing is 20 micron for small rods And 40 micron for big rods.



Fig-21.show the chrome plating on hydraulic cylinder rod.

14. Electron Plating

The electroplating is the process the anode is positively charged and cathode is negative charged. The term is also used for electrical oxidation. Raw material is dip into an electrolytic solution. At first raw material is immersed in to soap tank after few minutes send to anodic clean to etching tank after an 30 minutes it send to chrome tank.it help raw material as corrosion protection, life of raw material to increases, name of the coating done in this process.

Chrome plated coating is done, Soap tank-clean of rod. Anodic clean- sterocleanse, Etching tank-chrome acid, chrome tank contain-cathode act as material and job act as anode.

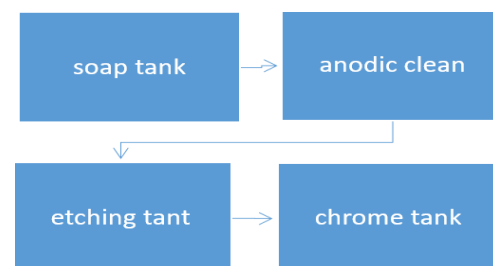

Fig-22.show the process of electron plating.



Fig-23. The thickness of rod measuring by mitutoyo 1301 thickness gauge is used quality chuck.

15. Result

The final product of hydraulic cylinder rod is ready to deliver to another company like hydraulic manufacturing, construction and earth moving, lifting, truck hydraulic etc.

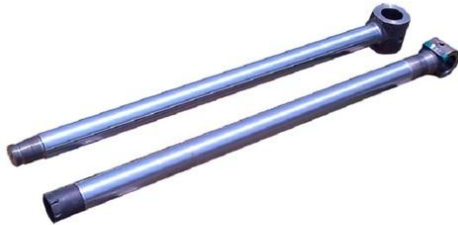

Fig-24. show the final product.

16. CONCLUSION

Here we have implemented Quality check operation after completion of each process. It shows delay in the every operation and Lead time is more. Well Qualified worker needed to have control over the process. So that Inspection operation is avoided. Once Inspection part is avoided we can achieve good economy of manufacturing.

ACKNOWLEDGEMENT

I would like to offer my sincerest thanks and deepest appreciation to all those who helped me to complete my training with a bunch of useful knowledge. Thank full to "WIPRO INFRASTRUCTURE ENGINEERING" for giving me such a golden opportunity of grateful stay in its industry as a trainee. I would like to express my deepest sense of respect and gratefulness T NAGESHWARA RAO, HOD OF MECHANICAL DEPT. RAMAKRISHNA RAO N, HRM JAGAYHT, QUALITY ENGINEER, for all their constant support, guidance.

REFERENCES

- [1] www.mechstudy.com
- [2] Manualzz.com
- [3] www.scribd.com
- [4] I have done my internship in Wipro infrastructure engineering "study on manufacturing of hydraulic cylinder piston".

BIOGRAPHIES



H A J sadiq sha :

Post student, Mechanical Engineering Department, Gitam deemed to be university, Nagadanahalli, Bangalore.