

# Design and Analysis of Core and Outrigger Structural System

Krutagn Patel<sup>1</sup>, Prof.Vishalkumar Patel<sup>2</sup>, Dr. Snehal Mevada<sup>3</sup>

<sup>1</sup>PG student, Structural Engineering Department, Birla Vishvakarma Mahavidyalaya, Gujarat, India

<sup>2</sup>Prof. Vishal Patel, Birla Vishvakarma Mahavidyalaya, Gujarat, India

<sup>3</sup>Dr.Snehal Mevada, Birla Vishvakarma Mahavidyalaya, Gujarat, India

\*\*\*

**Abstract** – In today's modern world as architectural requirement keeps on increasing it demands unique structural solution like core and outrigger structural system. This system basically designed in such a way that more forces are attracted towards the center core of building and less forces are carried by outer periphery of the building. Along with tall structure this system adopted for a building having medium height as well. This paper basically covers design of Core and Outrigger structural system using ETABS software, connection design between RCC core and steel structure, seismic analysis comparison with regular moment resisting framed RCC building, cost efficiency analysis compare to framed RCC building.

**Key Words:** Core and Outrigger structural system, Connection design, Cost efficiency.

## 1. INTRODUCTION

Complex geometry and building height makes job of structural engineer more difficult, so structural engineer needs adopt different structural system, core and outrigger is one of the solution for such complex problems. Basically Core and Outrigger structural system provides a large column free area and better resistance to seismic forces. Taipei 101 (509m), Hong Kong IFC 2(380 m), Hong Kong ICC (450 m), CTF tower (520 m), Capital gate (165 m) are the example of building constructed using Core and Outrigger structural system. Outrigger in this system act as a heavy deep beam and provides large lateral stiffness. By adopting more outrigger at precise position large resistance to lateral force and very less base moment can be achieved.

### 1.1 Experimental problem

For purpose of preparing ETABS model, an architectural plan of a commercial building is considered. Various building parameter used for core and outrigger building are given below.

- Material
  - Concrete grade – M 35
  - Steel grade- Fe410
- Section property
  - Beam sizes
    - ISMB 600
    - ISMB 500
  - Column sizes
    - 1500 x 300 x 40

- 1200 x 300 x 40
- 600 x 300 x 18
- 1200 x 300 x 18

- Core wall thickness – 900 mm
- Floor finish – 1.5 kN/m<sup>2</sup>
- Live load - 4 kN/m<sup>2</sup> (for passage)
- -2.5 kN/m<sup>2</sup> (for office)
- Height – 60 m
- Height of each storey – 3 m

For the purpose of comparison another building having RCC framed structure was prepared and building parameter are as follow;

- Material
  - Concrete grade – M 35
  - Steel grade- Fe500
- Section property
  - Beam sizes
    - 230\*600
    - 230\*450
  - Column sizes
    - 300 x 450
    - 300 x 750
    - 300 x 900
    - 300 x 1200
  - Shear wall sizes
    - 300 x 1500
    - 300 x 1650
    - 300 x 2100
    - 300 x 2250
    - 300 x 2400
- Slab thickness – 150 mm
- Wall thickness – 230 mm
- Floor finish – 1.5 kN/m<sup>2</sup>
- Live load - 4 kN/m<sup>2</sup> (for passage)
- -2.5 kN/m<sup>2</sup> (for office)
- Height – 60 m
- Height of each storey – 3 m

For a seismic and wind analysis following data considered;

- EARTHQUAKE LOAD

Location – Ahmedabad  
Eq. Zone – III  
Seismic Zone Factor- 0.16  
Importance Factor-1.2

Soil – Medium  
Response Reduction Factor- 5.0

- TIME HISTORY ANALYSIS

Bhuj Earthquake-2001  
Uttarkashi Earthquake -1991  
El Centro Earthquake – 1940

- WIND LOAD

Basic Wind Speed -39 m/s

Risk Coefficient(K1)-1.0

Terrain Category (K2)-Category-3

Topography Factor (K3)-1.0

Importance Factor(K4)-1.0

- LOAD COMBINATION

1.5(DL+LL)

1.5DL+1.5EQ-X

1.5DL-1.5EQ-X

1.5DL+1.5EQ-Y

1.5DL-1.5EQ-Y

1.2DL+1.2LL+1.2EQ-X

1.2DL+1.2LL-1.2EQ-X

1.2DL+1.2LL+1.2EQ-Y

1.2DL+1.2LL-1.2EQ-Y

0.9DL+1.5EQ-X

0.9DL-1.5EQ-X

0.9DL+1.5EQ-Y

0.9DL-1.5EQ-Y

1.5DL+1.5WL-X

1.5DL-1.5WL-X

1.5DL+1.5WL-Y

1.5DL-1.5WL-Y

1.2DL+1.2LL+1.2WL-X

1.2DL+1.2LL-1.2WL-X

1.2DL+1.2LL+1.2WL-Y

1.2DL+1.2LL-1.2WL-Y

0.9DL+1.5WL-X

0.9DL-1.5WL-X

0.9DL+1.5WL-Y

0.9DL-1.5WL-Y

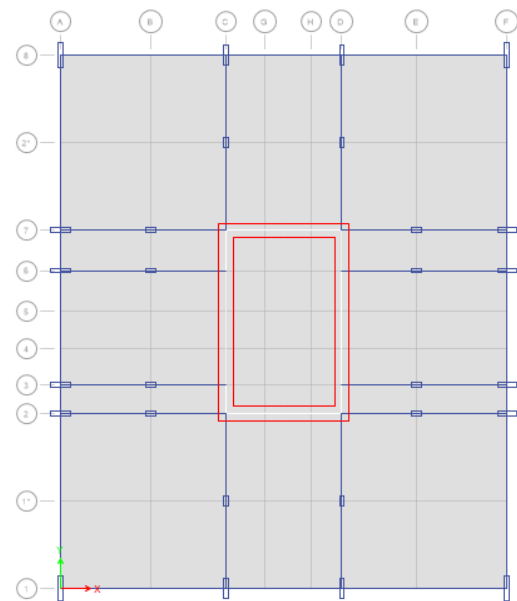

Fig -1: Core and Outrigger Model

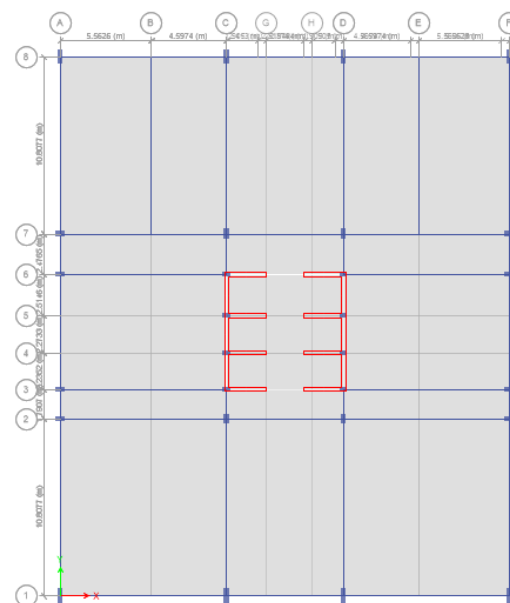

Fig 2 -: RCC frame model

## 2. RESULT AND DISCUSSION

### 2.1 Base Reaction

Basic advantage of adopting core and outrigger structure is to attract more forces towards the center of the building, it can be easily observed by value of reaction at the base. Table 1 shows the comparison of reaction at the base of core and reaction in the surrounding columns. Comparison shows that only approximately around 10% of core reaction are experienced at periphery column and more forces are getting transferred to the core of the building.

Sr.No.	REACTION BELOW CORE(kN)
1	25621.1396
2	25622.5045
3	25580.2238
4	25581.3094

Table -1: Reaction Below Core

MODAL MASS			
X	85.11%	68.72 %	Should be more than 65 %
Y	69.02 %	71.76 %	
MODAL LOAD			
X	93.18	95.33	Should be more than 90 %
Y	91.25	92.83	

Table -3: Seismic Checks

## 2.2 Base Shear Comparison

Base shear for wind analysis gives less values compared to earthquake analysis, So basically here comparison of base shear of Moment Resisting Frame and Core and Outrigger building are shown.

### RCC Building Base Shear in X Direction

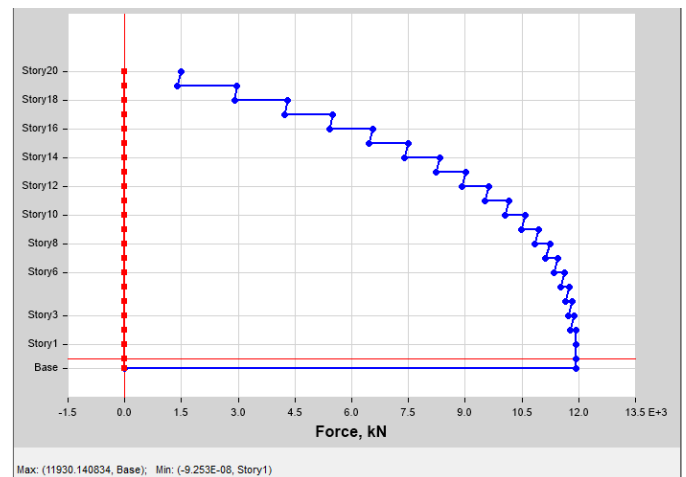

Fig 3 :- Base Shear X direction RCC Building

### RCC Building Base Shear in Y Direction

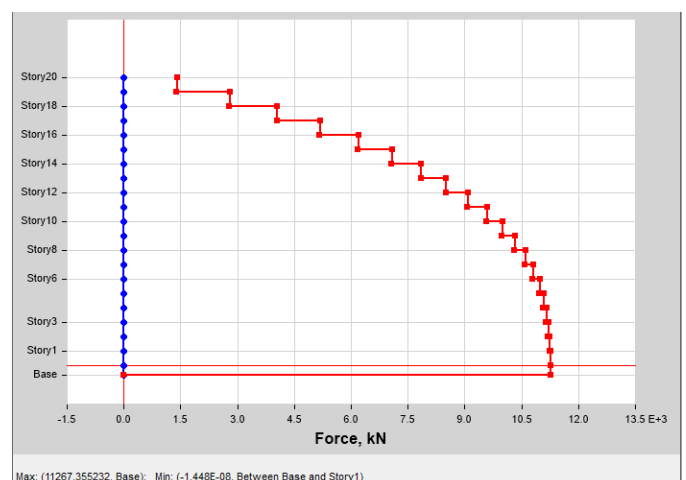

Fig 4 :- Base Shear Y direction RCC Building

Sr. No.	REACTION ON COLUMN AROUND THE CORE (kN)
1	2559.9619
2	2194.8294
3	1928.2753
4	2472.8495
5	3375.0421
6	3376.3136
7	2473.2569
8	1930.4629
9	2193.7754
10	2558.6629
11	3381.0696
12	3382.6445

Table -2: Reaction on Other Columns

For better comparison building parameters like static eccentricity, dynamic eccentricity, modal mass participation ratio, modal load participation ratio, maximum storey drift, maximum storey displacement are kept well below under limit without overlooking architectural requirements, values of all this parameter are given in table-3.

PARAMETER	RCC	STEEL	LIMITS
MAX.STOREY DISP.	31.425	30.191	120
MAX.DRIFT	2.555	2.037	12
ECCENTRICITY STATIC	X-0.012	X-0.330	
DYNAMIC	Y-0.669	Y-0.216	-
	X-1.39	X-1.867	
	Y-2.64	Y-1.969	

### Core and Outrigger Building Earthquake in X Direction

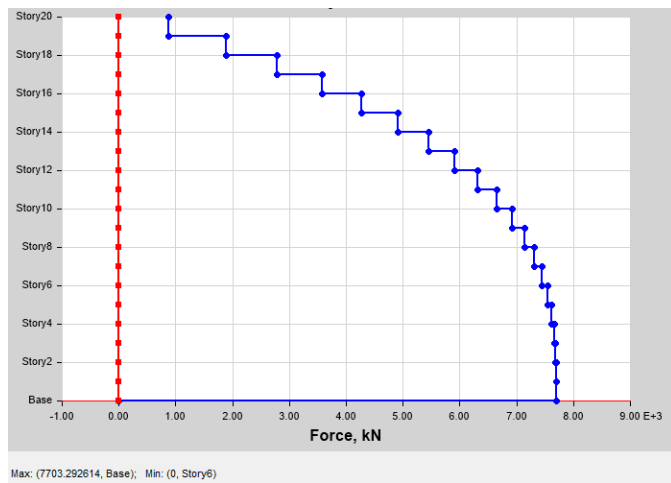

Fig 5 -: Base Shear in X Direction Core building

### Core and Outrigger Building Earthquake in Y Direction

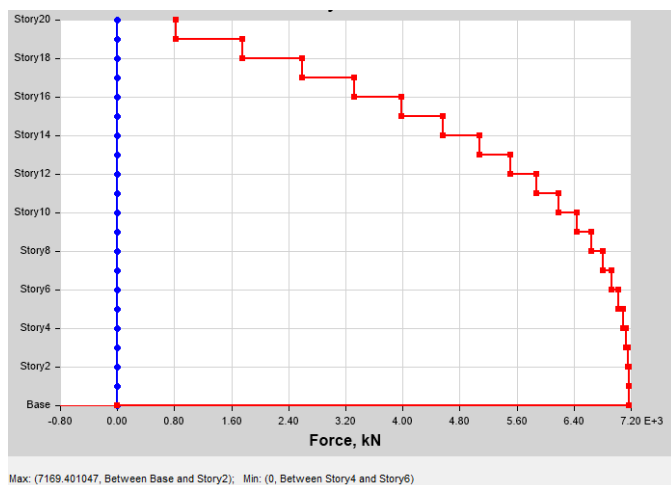

Fig 6 -: Base Shear in Y Direction Core building

From above figures it is clear that base shear in case of Core and Outrigger structural system is around 4000 kN more in both the directions.

### 2.3 Overturning Moment Comparison

Building	X-Direction	Y-Direction
RCC	566.875	535.382
Core	352.153	327.746

### 2.4 Connection Design

In case of Core and outrigger structures connection between RCC core wall and steel periphery structure needs to be designed. It can be done by using an insert plate which transfer forces from outer structure to inner core. Cross

sections of inserts plates are shown in figure (7-a & 7-b). For different values of reactions different thickness and different reinforcement are selected based on required bond stress values.

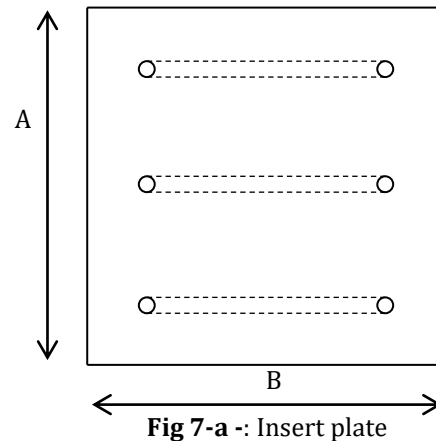

Fig 7-a -: Insert plate

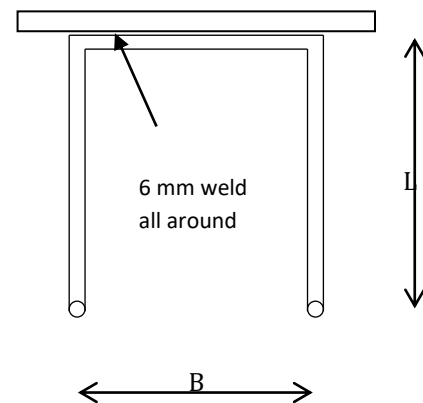

Fig 7-b -: Insert plate

Along with this connection between steel column and steel beam are also necessary to provide. Based on configuration requirement either of moment connection or shear connection are adopted for this purpose. Shear connection and moment connection basically designed from beam end forces received from ETABS. Typical diagram of this connections shown in figure (8-a & 8-b).

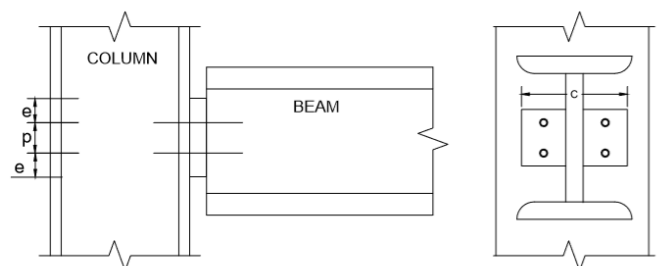

Fig 8-a -: Shear Connection

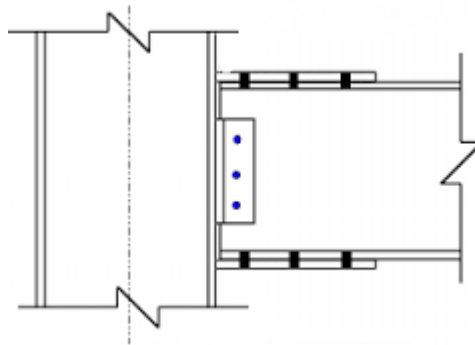

Fig 8-b -: Moment Connection

## 2.5 Time History Plot

### 2.5.1 RCC Building

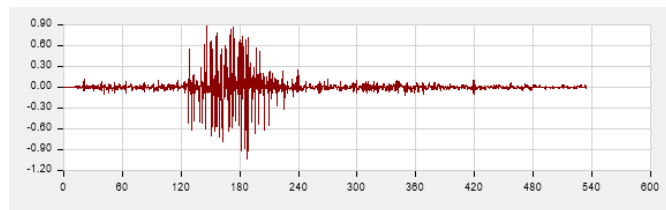

Figure-9-a Time History BHUJ

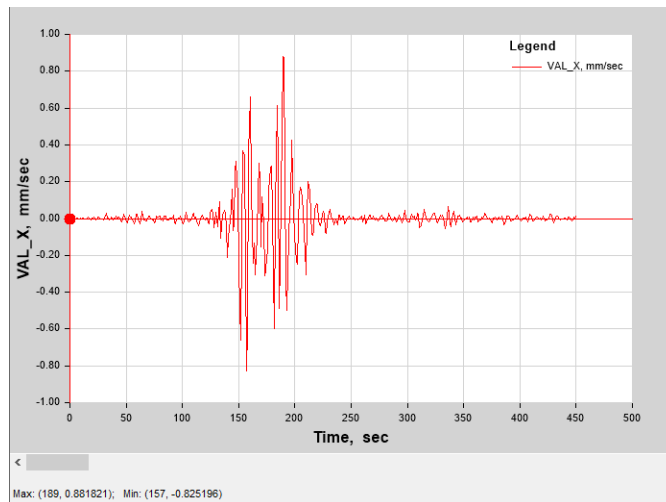

Figure-9-b Velocity vs Time

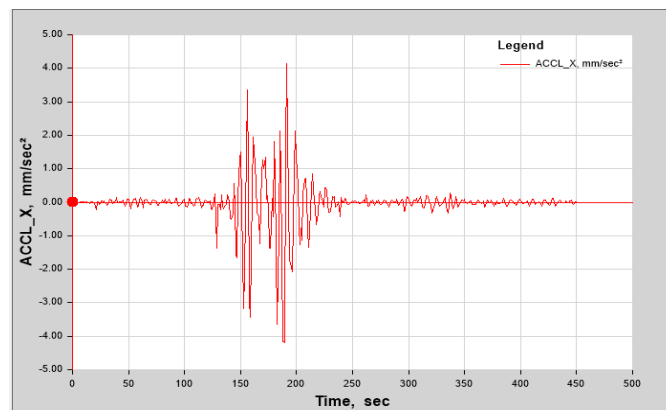

Figure-9-c Acceleration vs Time

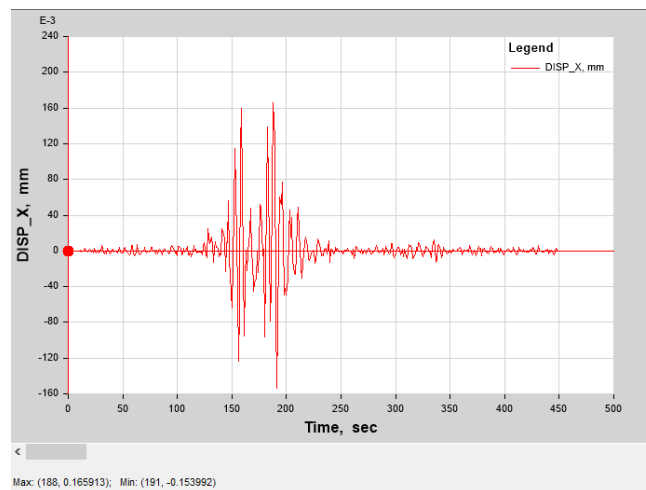

Figure-9-d Displacement vs Time

### 2.5.2 Core and Outrigger Building

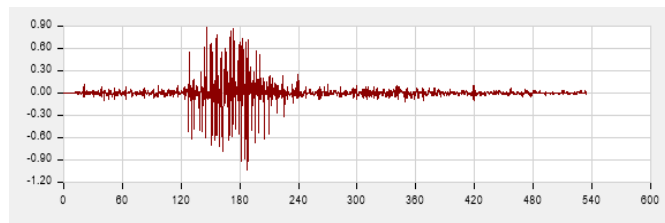

Figure-10-a Time History BHUJ

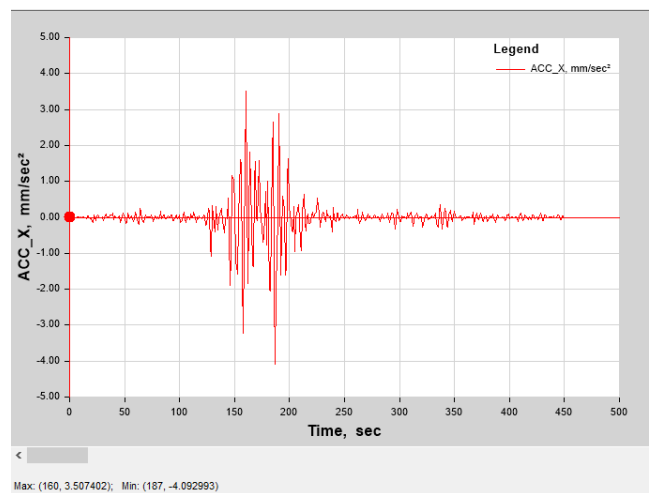

Figure-10-b Acceleration vs Time

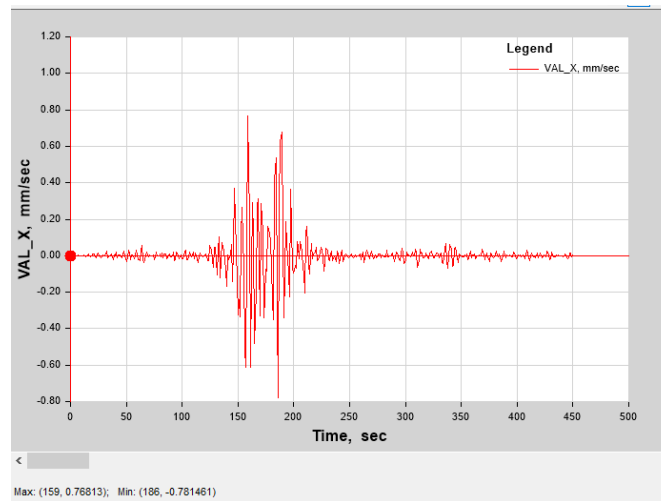

Figure-10-c Velocity vs Time

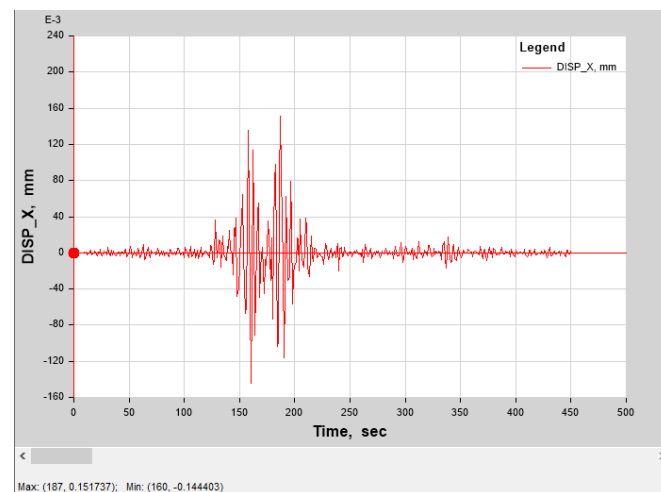

Figure-10-d Displacement vs Time

## 2.6 Cost efficiency analysis

Apart from adopting unique structural system another task is to design an economical structure, for this purpose core and outrigger building is compared with regular RCC frame building. For estimation of quantity in RCC building detailed beam, column and slab scheduling are prepared in RCDC software and based on rate per unit item estimation report is prepared. For steel building based on cross section of beam, column, connection detailing, core wall quantity detailed estimation report is prepared. Conclusion of cost estimation report shows that 5% more cost is needed for steel building construction compared to RCC building.

## 3. CONCLUSIONS

- By adopting core and outrigger structure more forces are attracted towards the centre of the building and less towards outer periphery of the building which proven good for seismic resistance.

- From value of overturning moments, it is clear that the less moment experienced at the base in Core and Outrigger building compared to RCC building.
- Core and outrigger structure makes inner core heavy and outer structure light. So, ultimate base shear generated at the base is very less compared to RCC structure.
- Only steel structure is light structure but steel with core becomes heavy to resist wind loads.
- Alone steel building can be more expensive but adopting core can make it cheaper.
- Around 5% more cost can give better seismic response and architectural requirement can be satisfied.
- Time History scale graph comparison also shows that the ultimate displacements, velocity and

acceleration are more in case of Core and Outrigger structural system compared to RCC structure.

## REFERENCES

- [1] Shieh, S.-S., Chang, C.-C., & Jong, J.-H. (2003). Structural design of composite super-columns for the Taipei 101 Tower. Proceedings of International Workshop on Steel and Concrete Composite Constructions, 25–33. Retrieved from [http://www.sefindia.org/forum/files/taipei\\_180.pdf](http://www.sefindia.org/forum/files/taipei_180.pdf)
- [2] Ho, G. W. M. (2016). The Evolution of Outrigger System in Tall Buildings. *International Journal of High-Rise Buildings*, 5(1), 21–30. <https://doi.org/10.21022/ijhrb.2016.5.1.21>
- [3] Ghangus, S., Sangeet, P., & Gupta, K. (2018). Typical Structural System of Tall RCC Buildings in India. 4305–4309.
- [4] Danani, P., & Parekh, U. (2016). Engineering Study of Structural Systems for Composite Construction in High Rise Building. *Indian Journal of Research*, 5(3), 228–233.
- [5] Sreelekshmi, S., & Kurian, S. S. (2016). Study of Outrigger Systems for High Rise Buildings. *International Journal of Innovative Research in Science, Engineering and Technology*, 5(8), 1489314900. <https://doi.org/10.15680/IJIRSET.2016.0508112>
- [6] Moon, K. S. (2018). Comparative evaluation of structural systems for tapered tall buildings. *Buildings*, 8(8). <https://doi.org/10.3390/buildings8080108>
- [7] Poulos, H. G. (2016). Tall building foundations: design methods and applications. *Innovative Infrastructure Solutions*, 1(1), 1–51. <https://doi.org/10.1007/s41062-016-0010-2>