

# A Review of Metal Inert Gas Welding on Aluminium and Copper Alloys

Syed Aqib Ali<sup>1</sup>, Dr. Ravindra Kumar<sup>2</sup>

<sup>1</sup>M.Tech Scholar, Department of Mechanical Engineering, SRMSCET, Bareilly

<sup>2</sup>HOD, Department of Mechanical Engineering, SRMSCET, Bareilly

-----\*\*\*-----

**Abstract** - The assembling procedure which is completed by joining two comparable and novel or different metals is called welding. The Metal Inert Gas for example regularly called as GMAW is the most well-known or widely utilized welding system or procedure in organizations. By the by, the high conductivity, high specular reflection, high unpredictability and high level of warm exchange render welding aluminum composites testing. The basic prerequisites in GMAW are welding voltage, current and power, while laser rate, laser force and concentrate point goal are the basic parameters in laser welding. The understanding of these measures additionally oversees the advancement of intermetallic components which have been appeared to get a negative impact on the mechanical and oxidation productivity of the few or unique weld joints. Right now checked comparative conditions for aluminum and copper amalgams. This article gives numerous strategies and systems to adjustment which writers use to assess for request to offer the factors it is more shrewd and the interconnected standards. This examines and investigates the MIG procedure for aluminum and copper composites, and the experts likewise talk about the long haul measurements. Such consequences of the discoveries will fill in as direction for welding experts to accomplish the best welding proficiency in vehicle sub-congregations, development, dockyards, and so on.

**Key Words:** Welding; MIG; Intermetallic materials; Aluminium alloys; Copper alloys.

## 1. INTRODUCTION

This Metal inert gas (MIG) welding is a segment of the time mentioned as gas metal twist welding (GMAW). MIG welding is a welding framework wherein an electrical bend advances between replenish able wire terminal and part metal working which incites both blend and joining. Alongside the wire terminal, a securing gas is provided by means of the welding framework which forestalls the framework against contaminants. Metal Inert Gas welding is vigorous and have less materials misfortune all through a large portion of the technique, which can be utilized as un-programmed and completely programmed welding [3].

**MIG Welding** - Metal inert gas (MIG) welding is a section of the time referenced as gas metal wind welding (GMAW). MIG welding is a welding framework wherein an electrical bend advances between replenish able wire terminal and part metal working which incites both blend and joining. Alongside the wire terminal, a securing gas is provided by means of the welding framework which forestalls the framework against contaminants. Metal Inert Gas welding is vigorous and have less materials misfortune all through a large portion of the technique, which can be utilized as un-programmed and completely programmed welding.

**Procedure parameters:** The trying different things with MIG welding relies upon an assortment of parameters which may impact the response to the exhibition. Characteristics of the welding technique essentially advantage the weld globule setup including infiltration, dot quality, dot width and affidavit rate, which is additionally the power of the metal infused per unit time. Such factors are: welding current, welding pressure, speed of flight. A decent decision of welding factors can improve the conceivable outcomes of accomplishing adequate yield welds.

## 2. WELDING OF ALUMINIUM ALLOYS

Aluminum combinations have less dissolving point contrasted and steels. The temperature inputs required for welding aluminum compounds is anyway more noteworthy than the warmth exertion required for welding steels. The more noteworthy warmth misfortune is initiated by the aluminum compounds ' altogether higher warm conductivity. It must be recollected that modern composites oftentimes show noteworthy contrasts in warm conductivity when welding aluminum amalgams. Such dissimilarity in warm conductivity can emerge in various different parameters for the welding.

The warm conductivity of a lower-focus compound, for example, the AA6060 composite, is ordinarily superior to anything the warm conductivity of a higher force combination, for example, the AA5083 amalgam. The AA6060 composite must be welded with more noteworthy circular segment current than the AA5083 combination for a predefined width and development speed of the welding light. Aluminum combinations have decreased dissolving point contrasted and steels.

The warmth exertion required for welding aluminum composites is anyway more prominent than the warmth input required for welding steels. The more noteworthy warmth input is activated by the aluminum compounds ' fundamentally higher warm conductivity. This ought to be recalled that the modern amalgams additionally show critical contrasts in warm conductivity when welding aluminum compounds. Such warm conductivity inconsistency can prompt different parameter settings for the weld. The warm conductivity of a diminished fixation amalgam, for example, the AA6060 compound, is generally a lot of improved than the warm conductivity of a more prominent focus composite, for example, the AA5083 combination. The AA6060 amalgam must be melded with more noteworthy bend flows than the AA5083 combination for a predetermined width and development speed of the welding light.

Table 1: Temperature of liquids and thermal conductivity index for four aluminium alloys

Material and delivery condition	Liquidus temperature (°C)	Coefficient of thermal conductivity (W/m K)
AA5083 O (AlMg4.5Mn)	638	105–120
AA5754 H32 (AlMg3)	645	130–140
AA6082 T6 (AlMgSi1)	649	150–170
AA6060 T6 (AlMgSi0.5)	652	180

### 2.1. Solubility of hydrogen

The generation of hydrogen gas porousness all through weld crystallization is among the most major issues in welding aluminum composites. Surely all aluminum welds contain noteworthy porosity amounts. The expansive porosity is stimulated by this difference among fluid and strong aluminum hydrogen solvency. At Fig. 1, Hydrogen dissolvability is demonstrated to be an outcome of temperatures in unadulterated aluminum. Gas porosity can develop when the hydrogen that has been consumed can't escape through crystallization. This alludes to the quantity of porosity will ascend as the welding speed expands (the light development level). Hydrogen dissolvability is directed by the aggregate of alloying segments and their structure.

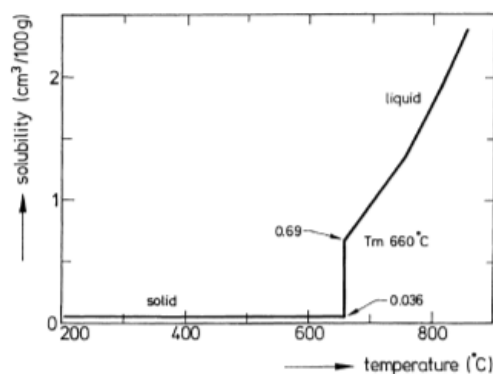

Fig. 1: Hydrogen solubility as a component of temperature in pure aluminium [1].

The variations in hydrogen solubility for technological alloys are low, so welding of dissimilar alloys would offer the very same issues as welding alloys with equivalent content.

### 2.2. Hot tearing

Some aluminum compounds are inclined to hot breaking. There might be additionally liquidation breaking in the affected warmth zone (HAZ), and hardening splitting in the weld. The capacity to break hot depends in addition to other things, on the combination's concoction structure. The 6xxx Standard amalgams, for instance, are more vulnerable to hot splitting than the

5xxx Standard compounds. The near weakness to hot breaking can be seen in Fig.2 for the 5xxx and 6xxx amalgams. The propensity of hardening splitting might be limited by a sufficient depiction of the filler item. For such an explanation the Al-Mg mixes are regularly welded with the ER5356 (AlMg5) filler metal. This is progressively difficult to check the proclivity of hot parting with welds of various aluminum mixes as this lead may rely upon the level of mix with the filler metal of various materials.

Whole of blending isn't really the equivalent for all the amalgams. It therefore implies that undeniably greater exposure must be paid to the hot tearing tendency when welding divergent aluminum amalgams than when welding a comparative compound. This article manages the results of Gas Tungsten Arc Welding of the 5xxx and 6xxx arrangement of disparate aluminum combinations. Welding unwavering quality, powerlessness to hot tearing and weld's mechanical attributes are tended to. Compounds of the 5xxx and 6xxx arrangement have been chosen since these combinations are most regularly utilized in aluminum improvement.

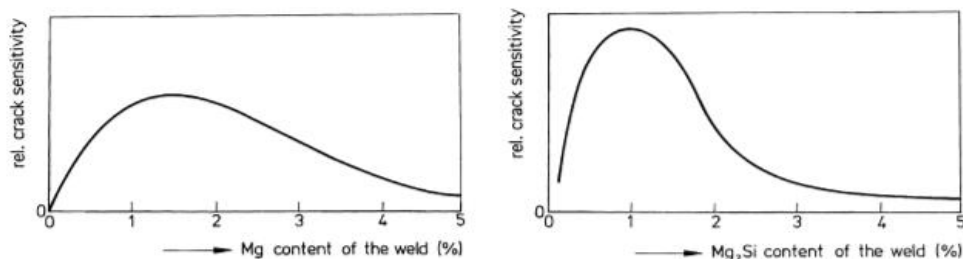

Fig. 2: Effect of alloying addition on hot cracking sensitivity.

### 3. TYPES OF ALUMINIUM ALLOYS

Unadulterated aluminum is a generally delicate metal. In any case, when joined with alloying components it can create a wide scope of mechanical properties. These compounds are arranged into families as per the chief alloying components with a four-digit recognizable proof framework. Here is a review of the of basic groups of aluminum composites and their weldability attributes alongside normal filler metals:

**1000 combinations:** Practically unadulterated aluminum, at 99% with follow components making up the rest. This family is utilized to convey electrical flow or for consumption opposition specifically situations. 1000 arrangement Aluminum composites are promptly weldable with 1100 filler metal.

**2000 composites:** This is a group of high-quality aviation composites. They are amazingly delicate to hot breaking and are the least weldable aluminum combinations. In particular, 2024 is the least weldable. Be that as it may, there are a few special cases, 2219 and 2519, which can be promptly welded with 2319 or 4043 filler metal.

**3000 amalgams:** An assortment of medium-quality aluminum amalgams. They are truly formable and are frequently are utilized for heat exchangers and climate control systems. 3000 arrangement aluminum composites are promptly weld able with either 4043 or 5356 filler metal.

**4000 amalgams:** These are normally utilized as welding or brazing filler combinations instead of base materials. In any case, when they are utilized as base materials, 4000 arrangement aluminum composites are promptly welded with 4043 filler metal.

**5000 compounds:** A group of high-quality sheet and plate compounds. 5000 arrangement aluminum composites are promptly welded with 5356 filler metal. Be that as it may, with more grounded amalgams, for example, 5083, 5183, or 5556, filler metals ought to be utilized.

**6000 compounds:** 6000 arrangement aluminum compounds are dubious to weld since they are inclined to splitting. Be that as it may, with the best possible methods, they can be promptly welded utilizing 4043 or 5356 filler metals.

**7000 compounds:** Another gathering of high-quality aviation compounds. These combinations are generally unweld able because of their powerlessness to hot-breaking and stress-consumption. 7075 is especially helpless. The special cases are 7003, 7005, and 7039, which are promptly weldable with 5356 filler. The compounds can be additionally arranged by being non-heat-treatable or heat-treatable amalgams.

4. WELDING OF COPPER ALLOYS:

Copper and copper amalgams give a magnificent blend of material attributes permitting them appropriate for a few creation conditions. Because of different their uncommon electrical and warm conductivity, eminent erosion obstruction, simplicity of assembling and great anxiety resistance, they are regularly used. Certain valuable highlights like reignite-obstruction, we metal-to-metal wear opposition, poor penetrable and unmistakable paint.

Table 2: Chemical composition of copper elements (mass fraction, %)

Zn	Pb	Sn	P	Ni	Mn	Al	Cu
0,0287	0,0171	0,00109	0,00876	0,00084	0,00028	0,15201	99,7719

Gas-metal circular segment welding is utilized to join of the coppers and copper composites for thickness under 3 mm, while GMAW is favored for area thickness over 3 mm and for the joining of aluminum bronzes, silicon bronzes and copper-nickel combinations.

Copper and its alloys are divided into nine major groups. These major groups are:

- *Coppers*, which contain a minimum of 99.3% **Cu**
- *High-copper alloys*, which contain up to 5% alloying elements
- *Copper-zinc alloys (brasses)*, which contain up to 40% **Zn**
- *Copper-tin alloys (phosphor bronzes)*, which contain up to 10% **Sn** and 0.2% **P**
- *Copper-aluminum alloys (aluminum bronzes)*, which contain up to 10% **Al**
- *Copper-silicon alloys (silicon bronzes)*, which contain up to 3% **Si**
- *Copper-nickel alloys*, which contain up to 30% **Ni**
- *Copper-zinc-nickel alloys (nickel silvers)*, which contain up to 7% **Zn** and 18% **Ni**
- *Special alloys*, which contain alloying elements to enhance a specific property or characteristic, for example machinability.

Alloy	UNS No.	Oxyfuel Gas Welding	SMAW	GMAW	GTAW	Resistance Welding	Solid-State Welding	Brazing	Soldering	Electron Beam Welding
ETP Copper	C11000-C11900	NR	NR	F	F	NR	G	E	G	NR
Oxygen-Free Copper	C102000	F	NR	G	G	NR	E	E	E	G
Deoxidized Copper	C12000 C123000	G	NR	E	E	NR	E	E	E	G
Beryllium-Copper	C17000-C17500	NR	F	G	G	F	F	G	G	F
Cadmium/Chromium Copper	C16200 C18200	NR	NR	G	G	NR	F	G	G	F
Red Brass - 85%	C23000	F	NR	G	G	F	G	E	E	—
Low Brass - 80%	C24000	F	NR	G	G	G	G	E	E	—
Cartridge Brass - 70%	C26000	F	NR	F	F	G	G	E	E	—
Leaded Brasses	C31400-C38590	NR	NR	NR	NR	NR	NR	E	G	—
Phosphor Bronzes	C50100-C52400	F	F	G	G	G	G	E	E	—
Copper-Nickel - 30%	C71500	F	F	G	G	G	G	E	E	F
Copper-Nickel - 10% Nickel-Silvers	C70600 C75200	F G	G NR	E G	E G	G F	G G	E E	E E	G —
Aluminum Bronze	C61300 C61400	NR	G	E	E	G	G	F	NR	G
Silicon Bronzes	C65100 C65500	G	F	E	E	G	G	E	G	G

E=Excellent      F=Fair      G=Good      NR= Not Recommended

Fig. 3: Applicable Joining Processes for Copper and Copper Alloys[9]



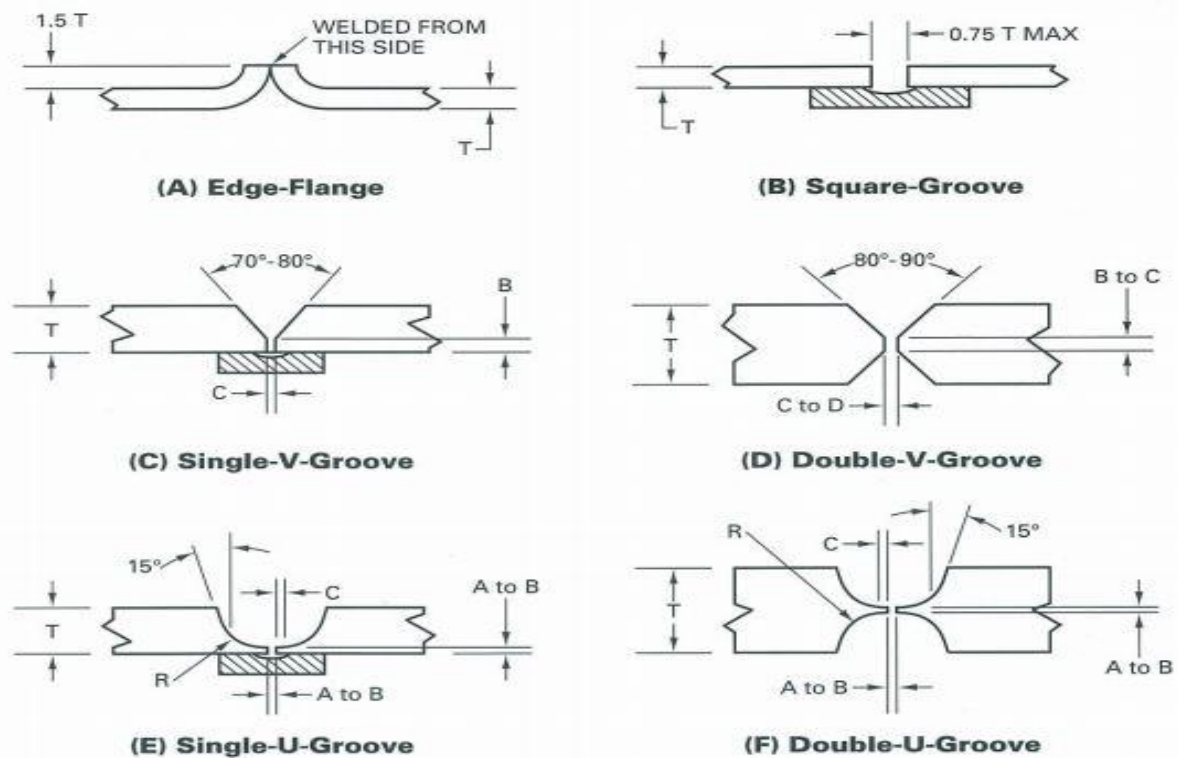

Note:  
 A = 1/16 in. (1.6 mm), B = 3/32 in. (2.4 mm), C = 1/8 in. (3.2 mm), D = 5/32 in. (4.0 mm),  
 R = 1/8 in. (3.2 mm), T = thickness.

Fig. 4: Joint Designs for Gas Metal Arc Welding of Copper [10]

These joints are produced by welding using Gas Metal Arc Welding of Copper Alloys. There are 6 types of joints that are produced using GMAW Welding.

Category	Description	Range of UNS Numbers <sup>a</sup>
	<u>Wrought alloys<sup>b</sup></u>	
Copper	Copper-99.3 percent minimum	C10100-C15760
High-copper alloys	Copper-96 to 99.2 percent	C16200-C19750
Brasses	Copper-zinc alloys	C20500-C28580
Leaded brasses	Copper-zinc-lead alloys	C31200-C38590
Tin brasses	Copper-zinc-tin alloys	C40400-C49080
Phosphor bronzes	Copper-tin alloys	C50100-C52400
Leaded phosphor bronzes	Copper-tin-lead-alloys	C53200-C54800
Aluminum bronzes	Copper-aluminum alloys	C60600-C64400
Silicon bronzes	Copper-silicon alloys	C64700-C66100
Miscellaneous brasses	Copper-zinc alloys	C66400-C69950
Copper-nickels	Nickel-3 to 30 percent	C70100-C72950
Nickel-silvers	Copper-nickel-zinc alloys	C73150-C79900
	<u>Cast alloys<sup>c</sup></u>	
Coppers	Copper-99.3 percent minimum	C80100-C81200
High-copper alloys	Copper-94 to 99.2 percent	C81300-C82800
Red brasses		C83300-C83810
Semi-red brasses	Copper-tin-zinc and copper-tin-zinc-lead alloys	C84200-C84800
Yellow brasses		C85200-C85800
Manganese bronze	Copper-zinc-iron alloys	C86100-C86800
Silicon bronzes and silicon brasses	Copper-zinc-silicon alloys	C87300-C87900
Tin bronzes	Copper-tin alloys	C90200-C91700
Leaded tin bronzes	Copper-tin-lead alloys	C92200-C94500
Nickel-tin bronzes	Copper-tin-nickel alloys	C94700-C94900
Aluminum bronzes	Copper-aluminum-iron and copper-aluminum-iron-nickel alloys	C95200-C95900
Copper-nickels	Copper-nickel-iron alloys	C96200-C96900
Nickel-silvers	Copper-nickel-zinc alloys	C97300-C97800
Leaded coppers	Copper-lead alloys	C98200-C98840
Special alloys		C99300-C99750

Fig.5 Copper and its alloys with their ranges.

## 5. CONCLUSION

Straight forward welding circuit of Al blends with explicit invention association and separating warm conductivity is difficult to accomplish for Gas Tungsten Arc Welding. With ideal execution, the light should be situated over the material's whole surface with the least warm conductivity. Most by a long shot of the physical properties of Cu amalgams, joint softening temperature, warm extension coefficients, and electromagnetic and warm conductivity, are fundamental for the welding strategy. Some alloying components diminish the electrical and warm conductivity of copper and copper combinations significantly. Different metal oxides noticeably affect Cu and Cu composites weld ability. Cu and its composites frequently contain modest quantities of unpredictable, destructive metal oxides. The requirement for a suitable ventilation framework that ensures the welder as well as the welding mechanical engineer is in this way more significant than when welding the ferrous metals.

## REFERENCES

- [1] N.C. Ransley, Jnl. Inst. Met. 74 (1948) 617.
- [2] J.R. Davies, Aluminium and Aluminium Alloys, ASM Speciality Handbook, ASM, OH, USA, ISBN 0-87170-496-X.
- [3] Bipin Kumar Srivastva, Dr. S.P. Tewari, JyotiPrakash "A review on effect of Preheating and/or Post Weld Heat Treatment (PWHT) on mechanical behavior of ferrous metals".International Journal of Engineering Science and Technology, Vol. 2(4), 2010, pp. 625-631.
- [4] G hargopal, PVR ravindrareddy, G Chandra mohanreddy, J V subrahmanyam "Parameter design for MIG welding of AL 65032 alloy using taguchi technique". Journal of scientific and industrial research, Volume: 70, October 2011, pp. 844-850.
- [5] Izzatul Aini Ibrahim, SyarulAsrafMohamat, Amalina Amir, AbdulGhalib "The effect of Gas Metal ArcWelding (GMAW) processes on different welding parameters".Elsevier, International Symposium onRobotics and Intelligent Sensors,2012, pp. 1502 – 1506.
- [6] P. Sivraj, D. Kanagarajan, V. Balasubramanian "Effect of post weld heat treatment on tensile properties and microstructure characteristics of friction stir welded armour grade AA7075-T651aluminium alloy".Defence Technology, Production and hosting by Elsevier, 10 January 2014, pp. 1-8.
- [7] Rakesh Kumar, Satish Kumar "Study of mechanical properties in mild steel using Metal Inert Gas welding".International Journal of Research in Engineering and Technology, Volume: 03, April 2014, pp 1-6.
- [8] Vikas Chauhan and Dr. R. S. Jadoun "Parametric optimization of MIG welding for stainless steel (SS-304) and low carbon steel using Taguchi design method".International Journal of Recent Scientific Research, Vol. 6, Issue 2, February 2015,pp. 2662-2666.
- [9] Bhadeshia HKDH, Svensson LE and Gretoft B. A model for the development of microstructure in low alloy steel (Fe-Mn-Si-C) weld deposits. Acta Metallurgica,1985; 33: 1273 – 1283.
- [10] Bhadeshia HKDH and Svensson LE. Modeling the Evolution of Microstructure inSteel Weld Metal. The Proceeding of the Mathematical Modeling of Weld Phenomenap, Institute of Materials, London, 109 – 182, 1993.