

# UNIVERSAL HARDWARE FOR AGRICULTURE AND WIRELESS DISPLAY

Sarvesh Ingle<sup>1</sup>, Sumit Kosalge<sup>2</sup>, Gaurav Bhavsar<sup>3</sup>, Ramgopal Sahu<sup>4</sup>

<sup>1,2,3</sup>Student, Department of Electronics and Telecommunication Engineering PES's Modern College of Engineering Pune, Maharashtra, India

<sup>4</sup>Asst. Professor, Department of Electronics and Telecommunication Engineering PES's Modern College of Engineering Pune, Maharashtra, India

\*\*\*

**Abstract** - Agriculture plays significant role in overall socioeconomic fabric of world and to turn in more profits in agriculture the important aspect is monitoring. There are several systems deployed to follow back atmospheric conditions using various sensors to monitor field along with irrigation control and compromising IOT and android application to monitor the data on mobile. Our system consists of various sensors to monitor the field and collected data is sent to raspberry pi using IOT and Arduino then displayed on the screen along with the suggestion based on the data. The proposed system is cheaper and easy to install.

**Key Words:** IOT, Raspberry Pi, Agriculture, Arduino

## 1. INTRODUCTION

Agriculture is considered as the basis of life for the human species as it is the main source of food grains and other raw materials. It also provides ample amount of employment opportunities to the people. Growth in agricultural sector is necessary for the development of economic condition of the country. Many farmers still use the traditional methods of farming which results in low yielding of crops and fruits. But wherever automation had been implemented, the yield has been improved. The only solution to this problem is smart agriculture by modernizing the current traditional methods of agriculture. In the proposed system various parameters of agriculture such as ambient temperature and humidity, soil moisture, detection of rain fall, carbonate concentrations in water, gas concentration are sensed through appropriate sensors and values are collected by Arduino and sent to cloud then Raspberry Pi over internet. Any individual would be able to take a prompt action to manage the field based on the data received from field. Basically, the proposed system contains two modules namely Arduino and raspberry pi and cloud acts as bridge between them. These modules can be mold in any applications such as cold warehouse, green house just by changing the sensors to sense appropriate conditions which make it an universal hardware.

## 2. Literature Review

In India about 70% of population depends upon farming and one third of the nation's capital comes from farming. Issues concerning agriculture have been always hindering the development of the country. The only solution to this

problem is smart agriculture by modernizing the current traditional methods of agriculture [1].

Agriculture sector being the backbone of the Indian economy deserves security. The integration of traditional methodology with latest technologies as Internet of Things and Wireless Sensor Networks can lead to agricultural modernization. This paper is oriented to accentuate the methods to solve such problems like identification of rodents, threats to crops and delivering real time notification based on information analysis and processing without human intervention [2].

There is a multidisciplinary model for smart agriculture based on the key technologies: Internet-of-Things (IoT), Sensors, Cloud-Computing, Mobile Computing, Big-Data analysis. Farmers, AgroMarketing agencies and Agro-Vendors need to be registered to the AgroCloud module through MobileApp module. AgroCloud storage is used to store the details of farmers, periodic soil properties of farmlands, agro-vendors and agro-marketing agencies, Agro e-governance schemes and current environmental conditions [3].

Internet of Things (IOT) is being used in several real time applications. The introduction of IOT along with the sensor network in agriculture refurbish the traditional way of farming. Online crop monitoring using IOT helps the farmers to stay connected to his field from anywhere and anytime. Various sensors are used to monitor and collect information about the field conditions. Collective data about the farm condition is sent to the farmer through GSM technology [4].

In this work, a system is developed to monitor crop-field using sensors (soil moisture, temperature, humidity, Light) and automate the irrigation system. The data from sensors are sent to Web server database using wireless transmission [5].

## 3. BLOCK DIAGRAM AND DESCRIPTION

The system contains two modules. One module is placed in field in which 4 sensors are interfaced with Atmega 328p along with ESP8266. The sensors used are DHT11, MQ2, Soil Moisture, Rainfall sensors. These sensors collect the data such as temperature, humidity, soil moisture, gas

concentration, rainfall detection. This data is sent to the ThingSpeak cloud through ESP8266 WIFI module. The data is stored on the cloud account which is password protected. Second module of system contains Raspberry Pi model 3b+ which has inbuilt WIFI and HDMI port through which a Monitor is connected. Here on Raspberry Pi data from cloud is downloaded, processed and displayed on the monitor along with suggestions and alert based on the data.

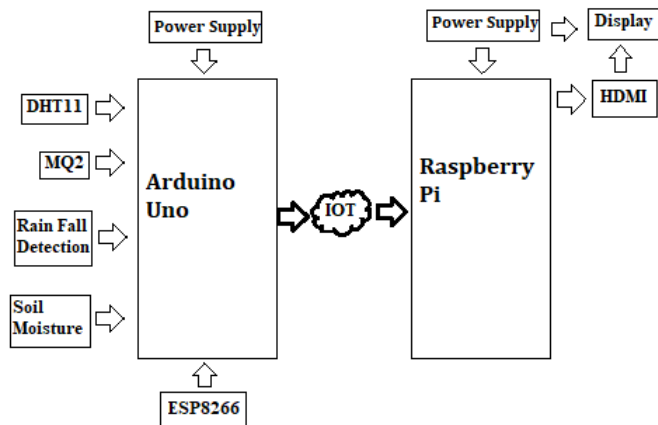

Fig -3.1: Block diagram of the system

#### 4. FLOWCHART

The system works according to the following flow chart.

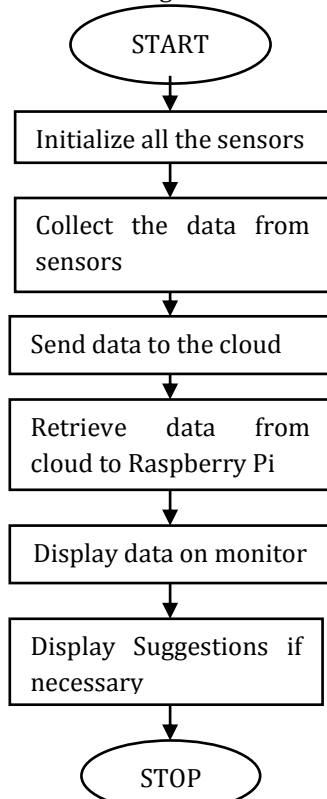

Fig -4.1: Flowchart of the system

The software for the proposed system is based on IOT. Initially, all the data regarding soil moisture, ambient temperature and humidity, rainfall detection sensed by the appropriate sensors. Then the sensed data is sent to cloud using Arduino and ESP module. The sensed data is then processed by the raspberry pi before displaying.

#### 5. RESULT

After successfully analysis of sensor data such as ambient temperature, humidity, gas concentration, rain drop detection along with the suggestions. The mechanism of suggestion in given system is done in such way that when any parameter which has to be analyzed surpasses the threshold value, system gives alert to the user.

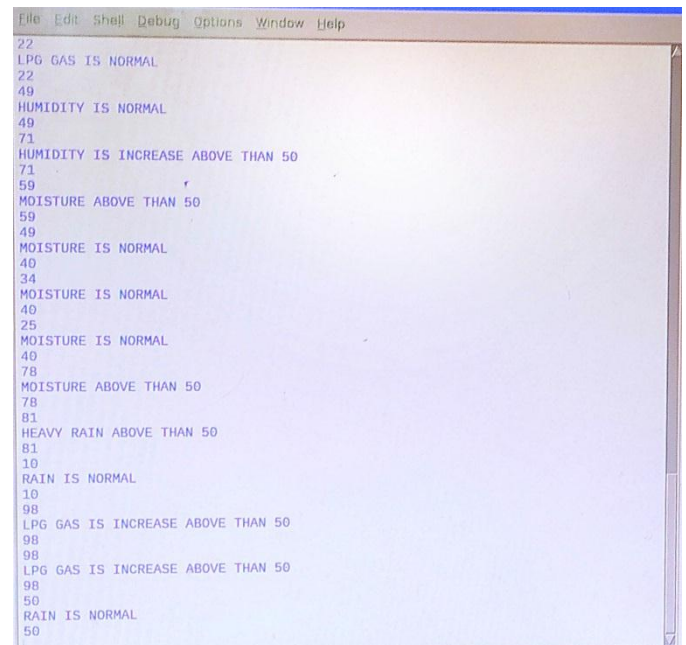

Fig -6.1: Data displayed on monitor after analyzing the sensor values

#### 7. CONCLUSION

This system covers the different aspect of monitoring in agriculture such as moisture of soil, ambient temperature, ambient humidity, detection of rainfall which are considered as important data for better yield of crop. And by analyzing these sensed data, appropriate action can be taken, which increases the productivity of crop. To make system more advanced, we can incorporate machine learning and AI to take intelligent decision while monitoring various parameters.

## 8. REFERENCES

- [1] Nikesh Gondchawar, R. S. Kawitkar, "IoT based Smart Agriculture", International Journal of Advanced Research in Computer and Communication Engineering, vol. 5, no. 6, pp. 2278-1021, June 2016.
- [2] Tanmay Baranwal, Nitika Pushpendra Kumar Pateriya, "Development of IoT based Smart Security and Monitoring Devices for Agriculture" in 6th International Conference - Cloud System and Big Data Engineering, IEEE, pp. 978-1-4673-8203-8/16, 2016.
- [3] Hemlata Channe1, Sukhesh Kothari2, Dipali Kadam3, "Multidisciplinary Model for Smart Agriculture using Internet-of-Things (IoT), Sensors, Cloud-Computing, Mobile-Computing Analysis", International Journal of Int.J. Computer Technology & Applications, Vol 6 (3), May-June 2015.
- [4] Naveen Balaji Gowthaman, V Nandhini, S Mithra, Navya Priya, "Imperial Journal of Interdisciplinary Research (IJIR) 4(1) · January 2018.
- [5] P. Rajalakshmi, S. Devi Mahalakshmi, "IOT Based Crop-Field Monitoring and Irrigation Automation" in 10th International conference on Intelligent systems and control (ISCO) 7-8 Jan 2016, published in IEEE Xplore, Nov 2016.