

A SMART WAY TO LEAVE SPACE FOR AMBULANCE USING RSSI

Mrs. K. Mekala devi¹, Disha.V², Jeyasri.M³, Monisha.S.S⁴

¹Associate professor, B.E-Department of Electronics and Communication Engineering, S.A Engineering college, Poonamalle, Chennai-77.

^{2,3,4}UG student, B.E-Department of Electronics and Communication Engineering, S.A Engineering college, Poonamalle, Chennai-77.

Abstract - With the increase in road density, certain causalities occur as a result of delay in getting a patient to an ambulance at the hospital. Using RSSI (Received Signal Strength Identification) we are intended to overcome this problem. We are all used to this in everyday life. This technique is suitable for overcome this issue. Node MCU acts as Receiver and Server acts as transmitter. Node MCU has inbuilt Wi-Fi (ESP-8266) module. It receives the signal from server and identifies that signals strength.

Key Words: RSSI, Node MCU, Transmitter, Wi-Fi, ESP-8266.

1. INTRODUCTION

Traffic congestion in many major cities around the world is a serious problem and has become a nightmare for the commuters in those towns. Large red light delay can also cause traffic congestion, etc. In traffic light, the delay of the respective light is hard coded, and it is not based on traffic. It is therefore important to model and automate traffic control in order to better meet this increasing demand. Ambulance is one of the big issues facing heavy traffic. As we all know, ambulances are the most critical transportation medical means in every country because they take patients to nearby hospitals. Yet due to heavy traffic, ambulances can often be seen stuck in traffic for long periods of time, thereby causing danger to the safety of patient. So our project is aimed at solving this ambulance issue. Once an ambulance approaches the vehicles other vehicles slow down automatically.

2. SYSTEM WORKING

We have Arduino microcontroller in our system that serves s the brain of our system, hence the whole

system program is stored in it. We have two units over here. There is one ambulance unit. Many cars have a separate model. RSSI technology helps to adjust the behavior if there are changes in the gap between two. The vehicle unit has one DC motor for showing vehicle speed, APR for playing pre loaded voice messages, and buzzer for alerting the driver. Therefore once the ambulance reaches the vehicles on the road it warns them, and the vehicle speed is controlled using PWM (Pulse Width Modulation). Then the by adjusting the duty cycle of the pulse width modulation, we can slow down the other vehicles.

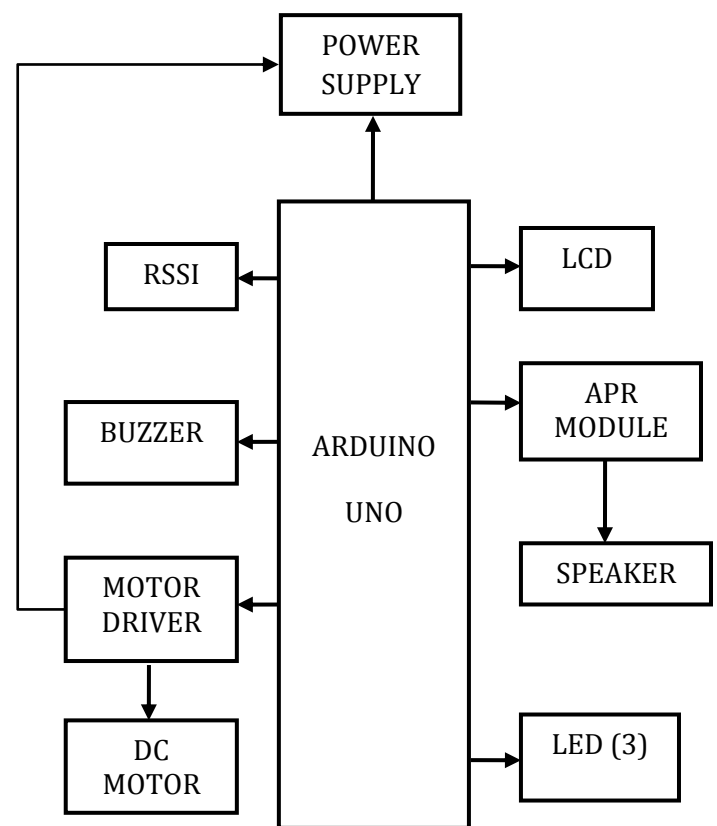

Fig -1: Transmitter section

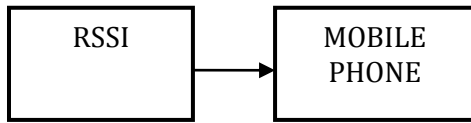

Fig - 2: Receiver section

3. COMPONENT DESCRIPTION

3.1 Arduino UNO

The UNO is the best board for getting electronics and coding going. If this is your first taste with platform tinkering, the UNO is the most powerful board you can start playing on. The UNO is the most commonly used and recorded board within the entire Arduino family.



Fig - 3: Arduino UNO microcontroller

Arduino Uno is a board based on the ATmega328P (datasheet) Microcontroller. It has 14 digital input / output pins (of which 6 can be used as PWM output), 6 analog inputs, a 16 MHz quartz crystal, a USB link, a power jack, an ICSP header and a reset key. It includes everything you need for microcontroller support.

Microcontroller	ATmega328P
Operating Voltage	5V
Input Voltage	7-12V
Input Voltage	6-20V
Digital I/O Pins	14 (of which 6 provide PWM output)
PWM Digital I/O Pins	6
Analog Input Pins	6

DC Current per I/O Pin	20 mA
DC Current for 3.3V Pin	50 mA
Flash Memory	32 KB
SRAM	2 KB
EEPROM	1 KB
Clock Speed	16 MHz
LED_BUILTIN	13
Length	68.6 mm
Width	53.4 mm
Weight	25 g

Table - 1: Arduino technical specification

3.2 RSSI

RSSI, or "Input Signal Strength Indicator," is a measure of how well an access point or router can detect a signal from your computer. It's a feature that helps to decide whether you've got enough signal to get a decent wireless link.

RSSI is a concept used to quantify, but has no absolute meaning, the relative quality of a transmitted signal to a client computer. The IEEE 802.11 standard (a broad documentation book for manufacturing WiFi equipment) specifies that RSSI should be on a scale of 0 to 255 and that each manufacturer of chipsets should determine their own "RSSI Max" value.

In an IEEE 802.11 device, RSSI is the relative signal intensity obtained in arbitrary units, in a wireless setting. RSSI is an indicator of the power level the transmitting radio receives after the antenna and a potential loss of the cable. The higher the RSSI number, then, the stronger the signal.

3.3 ESP-12E based Node MCU

The ESP8266 is the name of an Espressif Systems engineered micro controller. The ESP8266 itself is a self-contained Wi-Fi networking system that provides the ability to run self-contained applications as a bridge from existing micro controller to Wi-Fi, too. This module comes with a built in USB connector and a rich pin-out range. You can connect NodeMCUdevkit to your

laptop with a micro USB cable, and flash it easily, just like Arduino. It's breadboard friendly right away, too.



Fig - 4: ESP-12E based Node MCU

3.4 Buzzer

A buzzer or beeper is a electronic, electromechanical, or piezoelectric (piezo for short) audio signaling device. Typical uses of buzzers and beepers include warning systems, clocks, and user input validation, including a mouse click or keystroke.



Fig - 5: Buzzer

3.5 LCD

LCD screen is an electronic display board, and a wide range of applications are found. A 16x2 LCD display is a very simple module, and is commonly used in various devices and circuits. These modules are preferred to seven segments, and other LEDs in multi section. The reasons are: LCDs are economical; they are easily programmable; they have no limitation on showing different & even custom characters (unlike in seven segments), animations, etc.

3.6 APR 9600 voice IC

APR9600 is a low-cost, high-performance record / replay sound IC using analog flash storage technique. Also after power supply is removed from the module registered sound is maintained. The sound replayed shows high quality, with low noise. Sampling rate for a

recording time of 60 seconds is 4.2 kHz which provides 20Hz to 2.1 kHz of sound record / replay bandwidth.



Fig - 6: APR 9600 voice IC

3.7 Motor driver

Popular DC gear head motors need a current greater than 250mA. There are other built-in circuits, such as ATmega16 Microcontroller, 555 timers IC. But, this amount of current can not be supplied by the IC 74 series. If the motor is then connected directly to the o / p of the above-mentioned ICs, they may harm. A motor control circuit is required to overcome this issue, which can act as a bridge between the above mentioned motors and ICs (integrated circuits). H-bridge motor control circuit, such as using transistor, relays and using L293D / L298, is rendered in different ways.

3.8 DC Motor

Nearly every mechanical invention we see around us is done via an electric motor. Electrical devices are energy conversion methods. Engines take electrical energy and produce mechanical energy. Hundreds of machines that we use in our everyday lives are powered by electric motors.

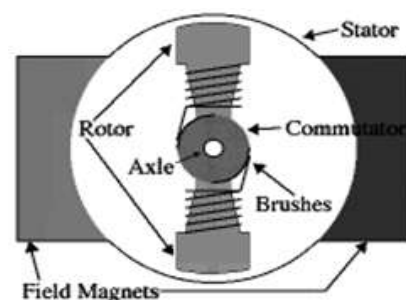

Fig - 7: DC Motor

A DC motor is an electric motor which operates with direct current. Operation is based on basic electromagnetism in any electric motor. A current carrying conductor produces a magnetic field when put in an external magnetic field, a force equal to the current in the conductor and the strength of the external magnetic field will be experienced. It is an apparatus that transforms electrical energy into mechanical energy. It operates on the fact that an actual carrying conductor put in a magnetic field is experiencing a force that causes it to rotate in relation to its original location.

4. FUTURE ENHANCEMENT

This model is being developed with the goal of helping the ambulance enter hospital as soon as possible. There are also ways it can be further improved. None of them do the following,

- Consideration of different traffic situations and how the system should respond to them.
- Safe contact between the emergency app and the server, so that only approved personnel can do the same thing. For example, a Login System
- Before entering the hospital, we can send the patient details to the hospital, so that the appropriate arrangements can be made.

5. CONCLUSION

Now a days, this program is most needed and beneficial for all people to avoid the unnecessary death due to late therapy. So, this program is built mainly for the purpose of an emergency and to give the patient care at the right time. The drivers are also quickly locating the ambulance when the driver with the APR voice is given the warning at nearby distances and the network. The driver must identify the ambulance and respond to give the ambulance the way forward. Here, the emergency selection will be split into three sections to take the steps required to prevent the accident. This device is so simple to use via smart phones on all ambulances and it is compulsory to repair all vehicles at the production companies.

REFERENCES

- [1] Michel Ferreira and Pedro M. d'Orey, Ieee Transactions On Intelligent Transportation Systems, Vol. 13, No. 1, March 2012.
- [2] Moises Diaz-Cabrera¹, Pietro Cerri and Javier Sanchez-Medina 15th International IEEE Conference on Intelligent Transportation Systems, 2012.
- [3] Nathaniel Fairfield Chris Urmson, IEEE International Conference on Robotics and Automation, 2011.
- [4] Stewart A. Birrell, Mark Fowkes, and Paul A. Jennings, IEEE Transactions on intelligent transportation systems, Vol. 15, No. 4, August 2014.
- [5] Nurulhuda J., Ho J.S. and Jamilah M.M. 2010. A survey of risk of accidents in Malaysia. In: of Miros Road Safety Conference, 9 pages.