

ADVANCED AUTOMATIC IRRIGATION SYSTEM WITH DAY AND NIGHT SENSING AND AUTO CONTROLLING OF MOTOR

Piyush V. Baviskar¹, Nikhil R. Chaudhari², Nitin P. Koli³, Akshata s. Kirtiwar⁴

¹(Electrical Engineering, G.H Rasoni Institute of Business Management, Jalgaon)

²(Electrical Engineering, G.H Rasoni Institute of Business Management, Jalgaon.)

³(Electrical Engineering, G.H Rasoni Institute of business Management, Jalgaon.)

⁴(Assistant Professor (Electrical Department)G.H. Rasoni Institute of Business management, Jalgaon.)

Abstract - This paper addresses the advanced system which improves agriculture processes by monitoring parameters like Temperature, Humidity and Soil condition based on IoT and Arduino uno. We going to design a proposed model which is runs on solar power by converted it to electrical form using solar PV cells and model which having a circuit with integrated temperature & humidity sensor and IoT with the help of NodeMCU (ESP-12). The system will continuously monitor the all parameters like Temperature, humidity and Soil Condition. All the processing of algorithm, calculation, processing, monitoring is designed with Arduino and NodeMCU (ESP-12) microcontroller. The dc powered motoring Pump is used to pump water and it can be operated over cloud using android phone equipped with Blynk application. Also there will be charge controller given for charging battery through AC power supply. In addition to that, user can monitor real time atmospheric parameters on his/her android mobile on Blynk app.

Key words: GSM, Arduino uno, solar panel moisture sensor, humidity sensor..

1. INTRODUCTION

INDIA'S major source of income is from agriculture sector and 70% of farmers and general people depend upon the agriculture. Irrigation requirement depends on soil properties like moisture and temperature and the type of crop which is grown in the soil. Technologies are developed for efficient use of water for irrigation purpose. In India, agricultural area receives power supply usually in non-peak hours; also frequent power cuts and low voltage supply creates a big problem to farmers. In India generally off-peak hours are usually at night times after 11 pm. If farmer fails to attend the irrigation, there's chance of wastage of water and electricity. Also, excess watering leads to soil damage. In order to regulate and monitor the irrigation process, smart and automatic irrigation system is developed, Implemented and tested. There is a need for automated irrigation system because it is simple and easy to install. This system uses values ON and OFF to control water motor.

The evolution of information technology has opened door to many impossibilities. Over years, our cell phones, tablets, automobiles, the increase of "smart" technology have

consumed the market and became the new standard within the industries. Smart irrigation is one such technology which have attracted interest of the various researchers and is evolving and improving from a couple of decade. This smart irrigation industry where water waste is minimized and is no longer sustainable socially, economically and conventionally as well. The idea and development of smart irrigation is essentially focused onto reduce human efforts also as reduce resources (water) and power consumption (electricity).

Water may be a very precious resource and must be properly utilized. Agriculture is one of those are as which consume a lot of water. Irrigation is a time consuming process and must be done on a timely basis. The aim of the article is to develop an auto irrigation system which measures the moisture of the soil and automatically activates or off the water system system.

The project requires less maintainance once it is installed installed. The circuit is based on arduino uno and also a soil moisture sensor. A properly configured soil moisture sensor can save to 60 percent of water utilized in irrigation. The designed system are often utilized in turf grass or with small garden plants. Irrigation is the most important part of agriculture there are two things that are need to be kept in mind while doing agriculture, to acquire information about the soil fertility and to measure content of moisture in soil.

This paper proposes not only to measure the soil content in the soil, but also to provide the required water to the soil automatically, when the moisture content is below the threshold value basic architecture of IOT. IOT is the big. Revolution for the next generation. A network which enables various physical devices, vehicles, home appliances or various electronic items embedded with software, sensors, actuators, to connect and exchange data is referred to as Internet of Things (IOT). Remote sensing and controlling of objects in an existing infrastructure is done with the help of IOT. With the help of this, more opportunities are created for integrating the physical world directly, into the computer based systems which results in increase in the efficiency, accuracy and economic benefits.

1.2. NECESSITY

In recent years, with the increasingly serious energy crisis and environmental pollution, solar energy, wind energy and other distributed renewable energy for its abundant resources, little pollution will play an important role in the future energy landscape. Owing to the randomness and volatility of solar and wind, the energy storage system is essential. As the energy storage element, battery have a large energy density to facilitate long-term storage of electrical energy and other characteristics, but it have such disadvantages of small power density, low charge and discharge efficiency, high power, and frequent charging and short discharging cycle life. as a power storage element, A solar photovoltaic (SPV) powered brushless DC (BLDC) motor drive and which is controlled by the arduino. The fundamental frequency switching pulses are generated to operate the VSI so as to minimize the switching losses and to reinforce the efficiency of proposed system. This system is also used in rural areas and hilly areas where there is no electrical power available for utilisation

2. LITRATURE REVIEW

Joaquín Gutiérrez, Juan Francisco Villa-Medina, Alejandra NietoGaribay, and Miguel Ángel Porta- Gándara, "Automated Irrigation System employing a Wireless Sensor Network and GPRS Module" soil moisture sensor, temperature sensors placed in root zone of plant and gateway unit handles the sensor information and transmit data to an internet application. One algorithm was developed for measure threshold values of temperature sensor and soil moisture sensor that was programmed into a microcontroller to manage water quantity. For power photovoltaic panel was used. Another facto like cellular-Internet interface used that allowed for data inspection and irrigation scheduling to be programmed through a web page. The automatic system was tested for 136 days and save 90% compared with traditional irrigation system. Three replicas of the automated system are used successfully in other places for 18 months. Because of its energy autonomy and low cost, the system has the potential to be useful in water limited geographically isolated area.

Samy Sadeky, Ayoub Al-Hamadiy, Bernd Michaelisy, Usama Sayedz, "An Acoustic Method for Soil Moisture Measurement" This paper describe that, soil moisture content has been detected using acoustic based technique was developed. The main propose of this system is development for measure soil moisture in real time method. The technique based on relationship between two quantities i.e. speed of sound and the degree of saturation with water in soils. This experiment found that the speed of sound decreases with the moisture content following, counting on the type of soil.

Jia Uddin, S.M. Taslim Reza, Qader Newaz, Jamal Uddin, Touhidul Islam, and Jong-Myon Kim, "Automated Irrigation

System Using Solar Power" This paper design a model of automatic irrigation system which is predicated on microcontroller and solar energy was used just for source of power supply. Various sensor are placed in paddy field. Sensors sense water level continuously and provides the knowledge to farmer through telephone. Farmer controls the motor using telephone without getting into paddy. If the water level reaches at danger level, automatically motor are going to be off without conformation of farmer.

Ms. Sweta S. Patil, Prof. Mrs. A.V. Malvijay, "Review for ARM based agriculture field monitoring system" The automatic system based on ARM and for communication GSM technology was used. Irrigation system provides foe adequate irrigation especially area which is real time. Soil moisture sensor placed in root zone in paddy and sense water level. The system was found out using ARM7TDMI core and GSM. GSM is a crucial a part of these this technique. System communicates using GSM. GSM operate through SMS and may be a link between ARM processor and centralized unit. This system detects climate condition and field condition in real time. This information send to user in the form of SMS and GSM modem is controlled with the help of standard set of AT (Attention) commands. These commands are wont to control majority of the functions of GSM model.

Zhang Feng Yulin, " Research on water-saving irrigation automatic control system based on Internet of things Institute of Information Technology" In the paper, automatic irrigation technique irrigated using wireless sensor network i.e. Zig-bee and internet technology. The idea was developed for improve irrigation system and reduced cost of irrigation water. Sensors are placed in farm and sense continuously and collect he information. This information stored at center monitor and also passes to data collection interface and then transmits to the wireless sensor node. Using this data system was control automatically using internet.

3. PROPOSED MODEL

I) BLOCK DIAGRAM

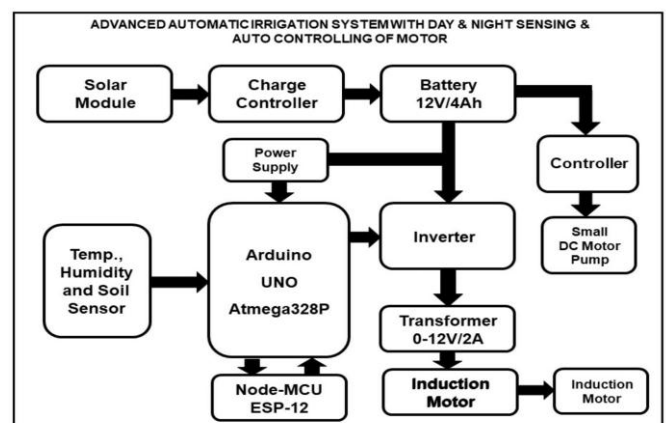

Fig. 1 block diagram of proposed system.

II) BLOCK DESCRIPTION

1) solar module



Fig. 2 solar module

Also called solar panels, a solar module may be a single photovoltaic panel that's an assembly of connected solar cells. The solar cells absorb sunlight as a source of energy to get electricity. An array of modules is wont to supply power to buildings. A solar module is generally consisting of an assembly of 6x10 solar cells. The solar cells' efficiency and wattage output can vary counting on the sort and quality of solar cells used. A solar module can home in energy production from 100-365 Watts of DC electricity. The higher is the wattage output, the more energy generation per solar module. A solar battery of modules consisting of upper energy-producing solar modules will, therefore, produce more electricity in less space than an array of lower producing modules. However, the cost is higher for greater producing modules.

2) Charge controller

A solar charge controller is generally a voltage or current controller to charge the battery and keep electric cells from overcharging of battery. It directs the voltage and current hailing from the solar panels setting off to the electrical cell. Generally, 12V boards/panels put call at the ballpark of 16 to 20V, so if there's no regulation the electrical cells will damage from overcharging. Generally, electric storage devices require around 14 to 14.5V to urge completely charged.

A charge controller basically controls the device voltage and opens the circuit, halting the charging, when the battery voltage ascents to a particular level. More charge controllers utilized a mechanical relay to open or shut the circuit, halting or beginning power avoiding to the electrical storage devices.

Generally, solar power systems utilize 12V of batteries. Solar panels can convey far more voltage than is obliged to charge the battery. The charge voltage might be kept at the simplest level while the time needed to completely charge the electrical storage devices is lessened. This permits the solar

systems to work optimally constantly. By running higher voltage within the wires from the solar panels to the charge controller, power dissipation within the wires is diminished fundamentally. The solar charge controllers also can control the reverse power flow. The charge controllers can find out when no power is originating from the solar panels and open the circuit separating the solar panels from the battery devices and halting the reverse current flow.

3) Sensors used

There is three sensors which are we going to used for our project temperature sensor, humidity sensor, soil moisture sensor

Temperature sensor is used for measurement of the soil temperature and the output of sensor id given to the Arduino uno.

Humidity sensor is used to detect the humidity present in the soil and its output is also given to Arduino uno.

Soil moisture sensor is used to detect moisture present in soil.

4) Arduino uno

It is used in our system for controlling of motor pump and for monitoring different parameters of the system.The Arduino Uno is an open-source microcontroller board supported the Microchip ATmega328P microcontroller and developed by Arduino.cc. The board is provided with sets of digital and analog input/output (I/O) pins which will be interfaced to varied expansion boards (shields) and other circuits. It has 20 digital input/output pins (of which 6 are often used as PWM outputs and 6 are often used as analog inputs), a 16 MHz resonator, a USB connection, an influence jack, an in-circuit system programming (ICSP) header, and a push button.

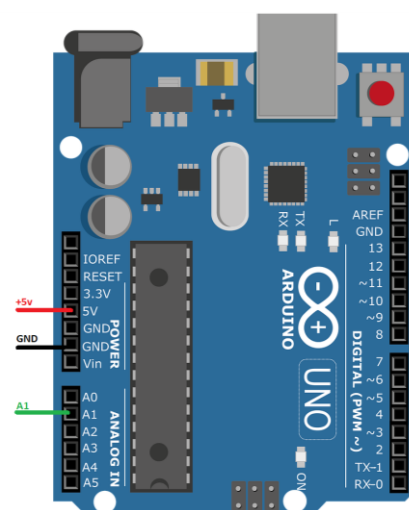

Fig. 3 Arduino uno

5) Battery

In this system we are going to use lead acid storage battery with capacity of 12V/4aH. The battery which uses sponge lead and lead peroxide for the conversion of the energy into electric power, such sort of battery is named a lead acid battery. The lead acid battery is most ordinarily utilized in the facility stations and substations because it's higher cell voltage and lower cost.[4] The lead acid battery uses the constant current constant voltage (CC/CV) charge method.

6) DC Motor's

There are two dc motors are needed for system one is of capacity 5V dc motor and another motor is of 12V DC motor pump, 5V motor pump is used for filling the water storage tank and 12V motor is used for to provide controlled water supply to the dry soil by using motor driver which is operates by Arduino uno

4. WORKING IDEA OF PROPOSED MODEL

The main aim of this project was to provide water to the plants or gardening automatically using microcontroller (Arduino Uno). We can automatically watering the plants when we are going on vacation or don't we have to bother my neighbors, Sometimes the neighbors do too much of watering and the plants end up dying anyway. By using timer based devices which used for watering the soil on set interval. They do not sense the soil moisture and therefore the ambient temperature to understand if the soil actually needs watering or not. Our purpose of project is that the synthetic application of water to the land or soil it's wont to assist in the growth of agricultural crops, maintenance of landscapes, and re vegetation of disturbed soils in dry areas and through periods of inadequate rainfall. When a zone comes on, the water flows through the lateral lines and ultimately finally finishes up at the irrigation electrode (drip) or mechanical device heads. Several sprinklers have pipe thread inlets on the lowest of them that permits a fitting and also the pipe to be connected to them. The sprinklers are usually used in the highest of the top flush with the bottom surface. As the method of dripping will reduce huge water losses it became a well-liked method by reducing the labor cost and increasing the yields. When the components are activated, all the components will read and gives the output signal to the controller, and the information will be displayed to the user (farmer). The sensor readings are analog in nature therefore the ADC pin within the controller will convert the analog signals into digital format. Then the controller will access information and when the motors are turned On/Off it'll be displayed on the LCD Panel, and serial monitor windows. There are many systems are available to water savings in various crops, from basic ones to more technologically advanced ones. For instance, in one system plant watering status was monitored and irrigation scheduled supported temperature presents in soil content of the plant

5. ADVANTAGES AND DISADVANTAGES

Advantages

1. High operational Accuracy
2. Automatic operation
3. We can operate motor by using GSM technology.
4. Solar control of motor gives saving of energy.
5. This system operate on DC supply or AC supply by using of charge controller.
6. This technology is endorsed for efficient automated irrigation systems and it may additionally provide a valuable tool for conserving water planning and irrigation scheduling which is extendable to different comparable agricultural crops. Maximum absorption of the water by using the plant is ensured by spreading the water uniformly.
7. This assignment can be used in large agricultural vicinity where human effort desires to be minimized. Many elements of the system can be personalized and fine-tuned thru software for a plant requirement.

Disadvantages

1. High cost of solar module.
2. It requires high power inverters for operation of motor

6. RESULT

This system which improves agriculture processes by monitoring parameters like temperature, humidity and soil condition based on IOT platform. We will developed a circuit with integrated temperature and humidity sensor and IOT using Node MCU (ESP-12). By all the counts and proven result we conclude that these is huge development in agriculture using IOT platform. It was mentioned earlier that this system is made especially for the people in remote areas. In those areas there is minimal or no power grid connection and the people irrigate their fields with the help of diesel engine. However, if we use smart irrigation system with electrical AC pump, then the farmers will not have to pay the fuel cost. Moreover, the maintenance cost of the smart system is very cheap. Now the following table compares between traditional system and smart irrigation system with respect to their fixed and variable costs.

REFERENCES

1. Samy Sadeky, Ayoub Al-Hamadiy, Bernd Michaelisy, Usama Sayedz, "An Acoustic Method for Soil Moisture Measurement", IEEE 2004.
2. Jia Uddin, S.M. Taslim Reza, Qader Newaz, Jamal Uddin, Touhidul Islam, and Jong-Myon Kim, "Automated Irrigation System Using Solar Power" IEEE 2012.

3. Ms. Sweta S. Patil, Prof. Mrs. A.V. Malvijay, "Review for ARM based agriculture field monitoring system", International Journal of Scientific and Research Publications, February 2014.
4. Zhang Feng Yulin, "Research on water-saving irrigation automatic control system based on Internet of things Institute of Information Technology", IEEE 2011.
5. Joaquín Gutiérrez, Juan Francisco Villa- Medina, Alejandra NietoGaribay, and Miguel ÁngelPorta Gándara,"Automated Irrigation System Using a Wireless Sensor Network and GPRS Module" IEEE, 2013.
6. M.S. Ghute, S. Soitkar and K.P. Kamble, "Smart Irrigation System using GSM Module", International Journal of Advanced Research in Computer and Communication Engineering (IJARCCE), Vol.6, July 2017.
7. E. U. Singh, M. Vyas, G. Sharma, S. P. Singh and S. Khan, "Solar Based Smart Irrigation System", International Journal of Recent Research Aspects (IJRRA), Vol. 3, pp. 105-108, Issue 1, March 2016.
8. M.S. Ghute, S. Soitkar and K.P. Kamble, "Smart Irrigation System using GSM Module", International Journal of Advanced Research in Computer and Communication Engineering (IJARCCE), Vol. 6, pp. 158-161, Issue 7, July 2017.
9. RANE, SHARVIN. "Automated irrigation system using x-bee and labview" 3rd International Conference on Electrical, Electronics, Engineering Trends, Communication, Optimization and Sciences (EEECOS)-2016.
10. Alamgir Mahzabin, Chowdhury Alma Taziz, Mullick Homaira Amina, Mollah Gloria, "Design and Implementation of an Automatic Irrigation System", IARJSET, Vol. 3, Issue 10, October 2016.
11. Joaquín Gutiérrez, Juan Francisco Villa-Medina, Alejandra NietoGaribay, and Miguel Ángel Porta-Gándara "Automated Irrigation System Using a Wireless Sensor Network and GPRS Module"IEEE 2013.
12. Piyush baviskar,nilesh N. sonar, vaishanavi N. Patil, Akshata s. kirtiwar, "advanced automatic irrigation system with day and night sensing and auto controlling of motor", IJET ,2020.