

# SMART HAND GLOVES FOR BLIND AND DUMB PEOPLE

Anshika Goel<sup>1</sup>, Pragati Mishra<sup>2</sup>, Samiksha Sahu<sup>3</sup>, Shivangee Jaiswal<sup>4</sup>

<sup>1,2,3,4</sup>Student, Electronics and Communication Engineering, Babu Banarasi Das National Institute of Technology and Management, Uttar Pradesh, India

\*\*\*

**Abstract** -In our life we meet many disable people, some of them are partially and some are completely disable. The partially impaired people like dumb, deaf and blind manages their life with difficulties and feel separated from others. Here communication plays a major role and make them feel better and help them to indulge in an activity where they can see themselves as an independent person.

This undertaking proposes a technique to structure an Electronic Hand Glove for Blind and Dumb individuals which will help them in setting up correspondence between Blind/Dumb and the outside world. The glove utilizes a ultrasonic sensor to distinguish an encompassing object and create a humming sound with the assistance of signal to alarm the Blinds and for a Dumb it utilizes metal contact, Bluetooth Module, Micro controller (Arduino Nano ) to build up correspondence with others by giving them a 'virtual voice'. The entire arrangement works with Android application by means of Bluetooth. The gloves utilize 12 distinct orders that are both perceptible and visual on any Android cell phone by means of an application.

**Keywords:** Ultrasonic sensor, Arduino nano, Bluetooth hc-05, buzzer, conducting metal(Push buttons)and a toggle switch.

## 1. Introduction

Disabilities to cope up with everyday activities. Since dumb person Smart Hand Gloves support people with is unable to speak, this smart glove allows him/her to turn their movement into both image and audible form. This also helps normal individual to understand what they're trying to say and respond accordingly. This Smart Gloves has a Home Appliance control facility from which a physically disabled person becomes independent to live. The fundamental objective of the actualized venture is to make a sheltered, simple to-utilize, light-weight keen hand gloves framework that can diminish obstructions for individuals with incapacities where they can remain with the race. A definitive motivation behind the framework is to furnish the visually impaired and idiotic with a basic and safe approach to explain their ordinary challenges.

By this motivation the project smart hand gloves are developed for disabled. The smart gloves provide the ability to the blind person to walk freely without anyone's help.

## 2. Literature Survey

In the course of the most recent couple of decades, new contraptions and advances have been investigated to design an average, Strong, and able structure to distinguish hindrances and to caution people about obstacles and to assist quiet with peopling to convey. There are a variety of structures that have certain limitations and clampdown.

D. Demonology, N.G. Average, "Wearable Obstacle Avoiding Electronic Travel Aids for Blind: A Survey"

proposed that a similar overview of compact/wearable impediment identification/shirking frameworks ought to be led with an end goal to educate the examination network and clients about the abilities of these frameworks and the advances in visual guide technology Handicapped individuals. The review depends on various framework highlights and execution boundaries which arrange them into classes, giving subjective quantitative measures.

A few specialists have thought of an assortment of likely alternatives. Hattie ET AL created a hand glove on the LCD screen with text support through a gadget interface with a PIC 18F8680 micro controller with DC power gracefully rather than battery. Enid ET AL had manufactured a mechanical hand to handle and raise different things. Wald created Automated Editing Apparatuses Recognition of discourse for the hard of hearing and hard hearing individuals progressively. Simone ET AL built up an ease strategy for figuring the scope of movement by hand and finger. Zhao ET AL built up a prosthetic hand framework with five fingers.

Hugo Fernandez, Jo Barbarossa "Dazzle Guide: a ultrasound sensor-based body region arrange for the direction of visually impaired individuals" This paper gives a correlative answer for the recognition of obstructions for daze individuals who as a rule utilize the white stick or the Seeing Eye hound and an answer for the location of impediments for as of late visually impaired individuals who don't utilize the white stick or the direct dog yet. This technique relies upon an arrangement of ultrasound sensors in the Body Area that gives sound-based input. The Network body field is canvassed in attire texture, permitting the oblivious in

regards to continue utilizing white stick or seeing eye hound.

### 3. Scope

The extent of this undertaking is resolved to accomplish the destinations. Ultrasonic sensors will be utilized as a sensor for the equipment so as to recognize snags on the front and it will impart a sign to the Arduino nano that goes about as a smaller scale controller. At that point the miniaturized scale controller forms information and imparts the sign to the bell that will direct its vibrating criticism. The application is produced for the product, with the assistance of the creator of the MIT application. That, as well, will create:

- Place easy to access
- Way to explore the surrounding area better.
- Low cost device easy to handle
- Versatile device and safe to use
- Time saves and interdependency reduces.

### 3.1 Proposed System

The framework proposed comprises of the accompanying fundamental parts: 1) smaller scale

#### INPUT COMMUNICATION OUTPUT

controller 2) ultrasonic sensor 3) Bluetooth module H C-05 4) Vibration engine 5) flip switch 6) Buzzer. Figure shows calculated machine square outline. The circuit utilizes Arduino nano as the focal small-scale controller that handles the sensor location and gives input on the signal and vibration engine gadgets. Arduino offers a ultrasonic sensor with 5 v dc to the V CC board. Pin no D 11 is called M O SI (Master out Slave in) pin which acts as an ace line for sending information to Arduino-associated peripherals. The controlling information is sent from the S PI pin in Arduino no D 11 to trigger sensor input. In like manner, the information that is gotten when the sensor detects the article's nearness inside its range is transmitted as a sign from the sensor's information reverberation pin to the Arduino's pin no. D 1 0. Both pin number D 8 and pin number D 7 Arduino fills in as the yield sticks that transmit the signs to the engine and the bell, in this manner initiating them until the sensor distinguishes an item. Utilizing a flip switch and a DC male force jack the force flexibly is given to the Arduino from a 9 V battery. Utilize the flip change to check if the bell and the vibration engine works impeccably. Arduino nano furnishes Bluetooth module hc-05 with 5 v to V CC pin. Both Arduino nano module and Bluetooth h c-05 G ND Connections are comparative. Bluetooth module hc-05 RX associates through voltage divider to Arduino nano pin 3 (TX). Bluetooth module hc-05 TX associates straightforwardly to Arduino nano pin 2 (RX).

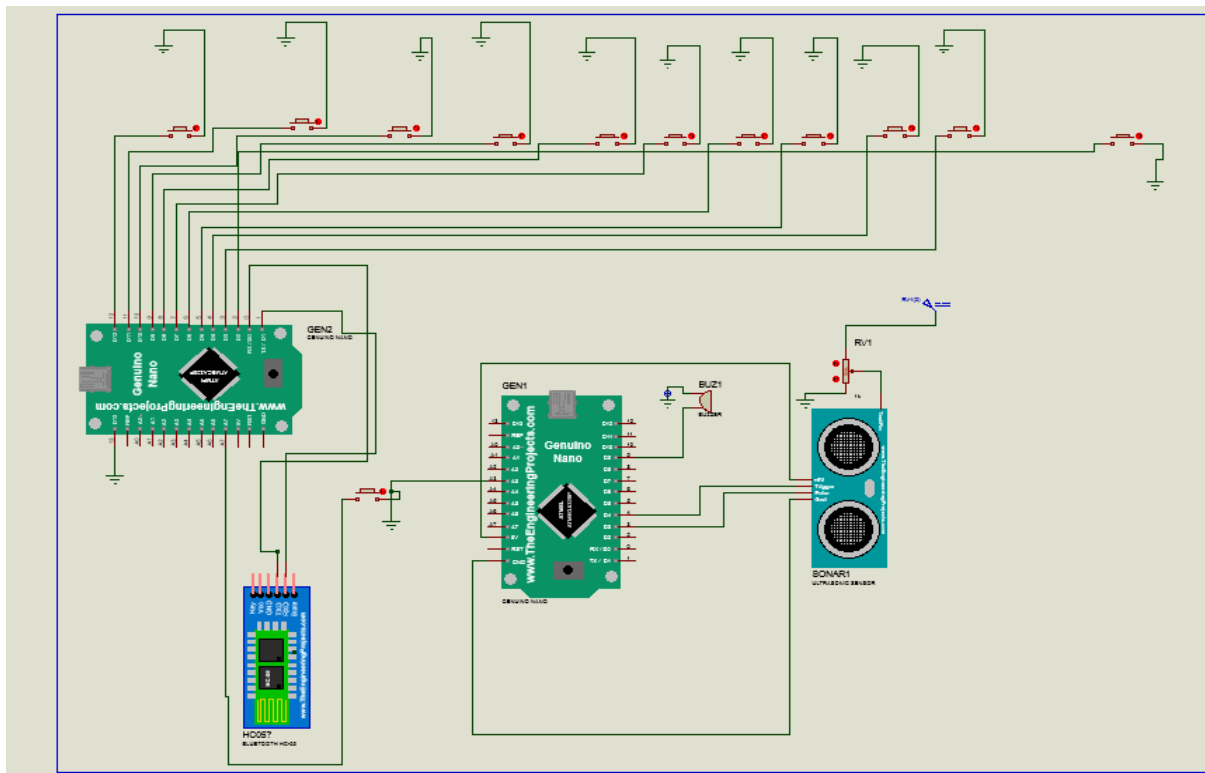

Fig-1: Circuit Diagram for proposed hand glove for blind and dumb

#### 4. Methodology

This project is proposed specifically to help the blind, deaf and dumb so that they can interact with other people. We will design a small and light Smart-Glove, so it can be carried comfortably by them.

##### 4.1 Hardware Assembly

The genuinely incapacitated individual needs to wear this glove on his hand, the glove is good with any left or right hand. There will be a few contacts on the fingers, one on the thumb and three contacts on each finger. These contacts are associated with the Arduino and the controller is customized to have a touch between the thumb contact and any of the contacts on the fingers at that point unravelling a particular order compares to that specific contact. The decoded order is at that point sent via Bluetooth to the app where it responds accordingly.

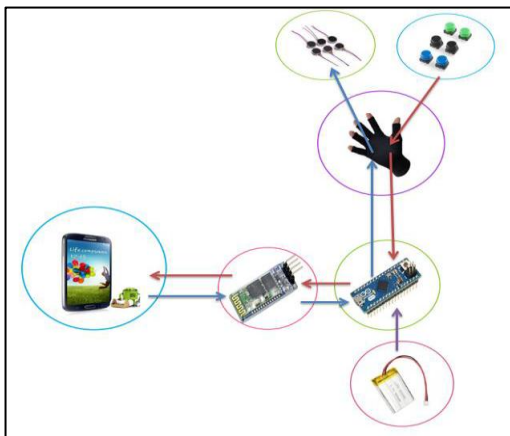
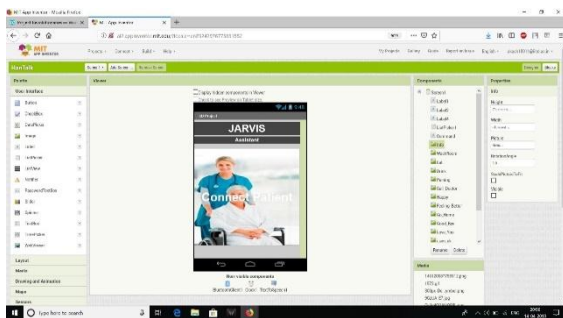

Fig-1.2 Smart glove using metal contacts

##### 4.2 Software Assembly:

The application that we use in our venture is created utilizing MIT App Inventor, which gives an online stage to assemble the applications with no coding information. Simplified applications are anything but difficult to utilize, and support. The gadget is intended to transmit the message sent by the glove in both discernible and



This gadget will likewise assist the visually impaired with navigating without holding a stick that is somewhat irritating to them. They can wear it as a glove and it can work well indeed, they simply need a smidgen of preparing to utilize it. We've fabricated an uncommon Wearable gadget dependent on Arduino board that can be worn by blinds like a material. This framework is likewise fitted with a ultrasonic sensor, when the ultrasonic sensor recognizes hindrances, the gadget will tell the client by means of vibrations and blares with a sound. Vibration force and blaring rate increment with decline in separation and this is a completely computerized gadget. Both the gadgets will switch between each other utilizing a flip switch with the goal that a similar glove can serve for dual purpose.

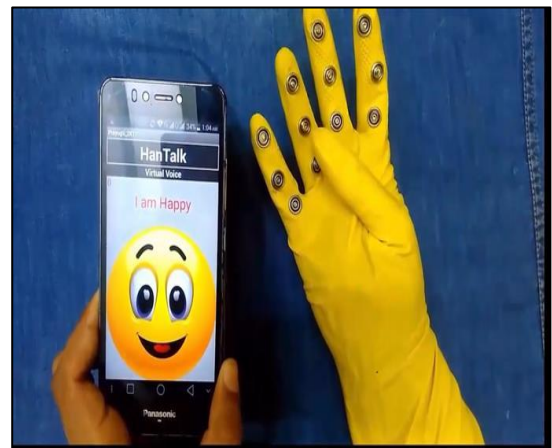

Fig-1.3 Smart glove design

picture, with the ex-presser having around 12 unique articulations. It is exceptionally easy to utilize, and effectively join to the glove through Bluetooth. At the point when combined, it can work unaltered as long as the telephone is inside the Bluetooth's go and furthermore offers arrangement highlights relying upon the subject's need.



Fig-1.4 Third eye for blind

#### 5. Conclusion

In the end, with this project, we aim to support the largest number of blind, deaf and dumb people. There

are several features that can be improved to achieve this. The system should mainly be extended to support other languages, and the system can use multiple ways to Communicate, you can use Bluetooth connection, which allows you to connect faster and with a better range. The most obvious advantage of this is its widespread use worldwide.

This undertaking portrays the structure and working of the framework that is valuable to speak with each other

#### **References**

- [1] Shraga Shovel, Ulrich Iowan, Johann Bornstein. Nav Belt and the Robotics & Automation Guide Cane, IEEE Transactions. 2003; paragraph 10(1):9-20.
- [2] The D. Demopoulos, N.G. Bourdais, "Electronic Travel Aids for Blind Wearing Obstacle Avoidance: A Survey," IEEE Trans. Man and Cybernetics systems Part C: Applications and Reviews, vol. 40, number 1, pp. 25-35, 2015.
- [3] Hugo Fernandes, João Barroso "Blind Guide: a body area network based on ultrasonic sensors to guide Blind people's 6th International Software Development and Enhancement Technologies Conference Exclusion of accessibility and Info Fighting (DSAI 2015).
- [4] Sabari's S. Visually Impaired Navigation Device using Microcontroller, International Journal of Engineering and Advanced Technology (IJEAT), 2013; 2(4):139-143.

and the typical individuals for the visually impaired, moronic and hard of hearing. The imbecilic individuals utilize their standard communication via gestures which the average citizens can't comprehend and their motions are difficult to comprehend. With this wearable keen glove, stupid individuals or patients can discuss effectively by basically tapping the specks on the glove with their thumb bringing about 12 sound and picture orders on any android cell phone through an application.