

“IoT BASED SMART MANGEMENT AND MONITORING SYSTEM FOR AGRICULTURE ACTIVITIES”

Jay P Patel¹, Vatsal Bhoir², Praful Khaniya³, Vipul Patel⁴

^{1,2,3}Students of B.E Electronics & Communication Engineering in Laxmi Institute of Technology, Sarigam

⁴Assistant Professor, Department of Electronics & Communication Engineering in Laxmi Institute of Technology, Sarigam

Abstract— Internet of Things (IoT) System is a system which can be used to solve a lot of issues which is caused due to the far distance communication. It is the system which can connect many peoples to their issues which is caused very far away from where they are. In villages there are people who are affected due to the issues which they can't see through their naked eyes. Issues like they can't exactly know the temperature around them and they can't even measure the soil moisture by seeing the farm and they can't even check the humidity in the air. So in this paper we proposed a design through which the farmer can easily be able to know the parameters of the nature like temperature, humidity and soil moisture level and they can even get the notification through text message and e-mail. And they can even control the water pump through anywhere in the world through the website. The system we designed is know as “IoT BASED SMART MANGEMENT AND MONITORING SYSTEM FOR AGRICULTURE ACTIVITIES”

Keywords—IOT, GSM, MONITORING, MANAGEMENT, AGRICULTURE

i. INTRODUCTION

This paper proposed a design which will help the farmers to know their field even better. They can even check the whole farm's temperature, humidity and soil moisture of their grounds through the system we designed. Our design consist of two major steps which is monitoring of the parameters of the field and second management of the parameters according to the farmers choice.

Monitoring: This system will help the farmers to know the environment parameters like temperature, humidity and soil moisture level.

Management: Through this system user can control the water pump by sending the command through the webpage using IoT System.

ii. LITERATURE SURVEY

This section includes the literature survey for this system.

A. Smart AGRO Using ARDUINO and GSM:

The aim of this project is to minimize the manual intervention by the farmer, which is why we are using a ARDUINO UNO. If the wild animals is entering inside the farm land means will be altered. So this project is very useful to modern agriculture.

B. Agriculture Crop Monitoring using GSM in WSN:

The aim of this project is by using GSM, the farmer will be able to monitor whenever he is unavailable to maintain his land. The farmers can access their land from anywhere. He will be asked to monitor using GSM so that it will avoid placing the substitute for his land. He can also monitor his crop by control over his mobile phones.

C. Smart Agriculture Monitoring and Security System:

The aim of this project is to use various sensors integrated to an embedded controller for performing monitoring services and security. It is expected that it would be a low cost, reliable smart system catering to the needs of rural mass.

iii. DESIGN

Circuit Diagram of the proposed design:

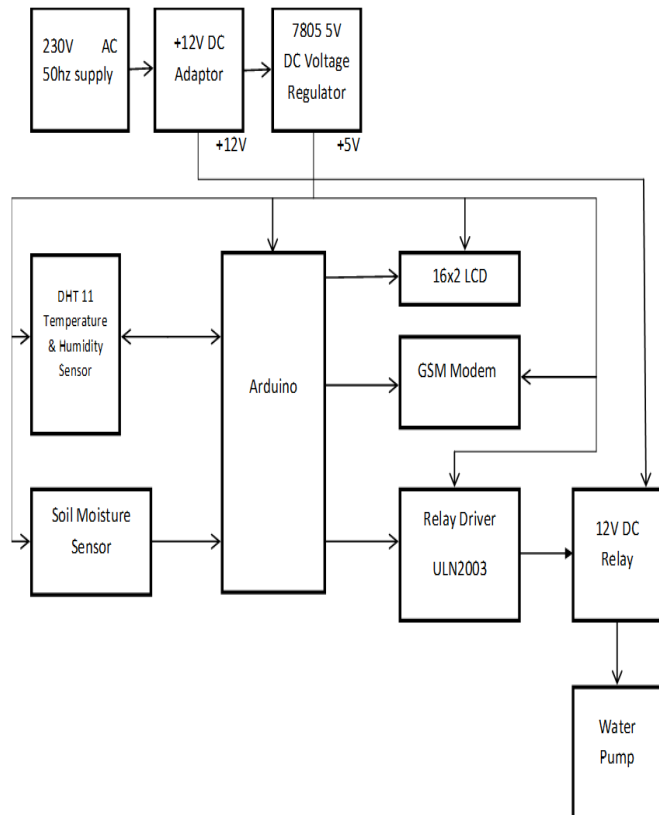

iv. WORKING PRINCIPLE

In this design we are using many equipments to simultaneously work according to the design. For power supply we are using 12V DC Adaptor and to regulate the required voltage we are using DC Voltage Regulator. To sense the temperature around the field and humidity in the air around the field we are using DHT11 Temperature & Humidity Sensor. To sense the soil moisture in the soil we are using Soil Moisture Sensor. Both the sensor will be connected to the Arduino. We are also using a GSM Modem in the design to send the information about the parameters to the mobile phone of the user. In this we have designed the system in that way that if the parameters go high than the threshold value than it will send the user a text message about the parameters going high and it will alert the user about the field. We are using a LCD display in the system which will be connected to the project. In this display it will continuously keep on showing the parameters. In this we are using a Relay which is connected to the Relay Driver. The Relay driver will control the relay. And the will control the water pump. When the parameters will go high it will automatically on the relay and the relay will trigger the water pump. In this we have programmed the computer language in the

arduino. In that program we have connected all the components to give the value and send it to the server. We have designed a website for this system. In that website all the data of the parameters will be recorded. And through the website the user can start and stop the pump by just clicking a button. This is the whole working procedure of our design. Through this the user will be connected to its field even if he is very far away from the field.

v. FLOW CHART

The following is the process flow of the system.

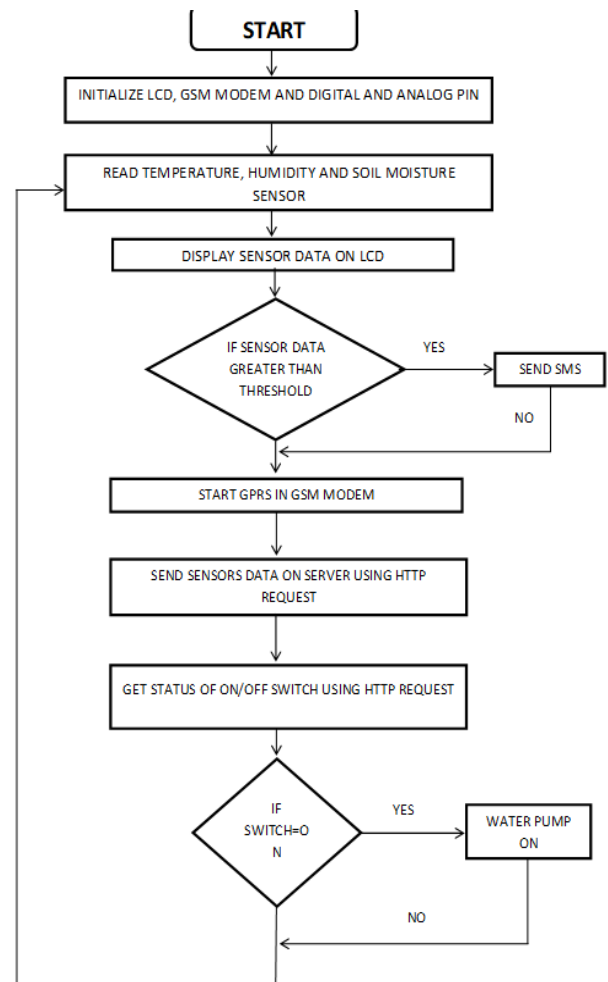

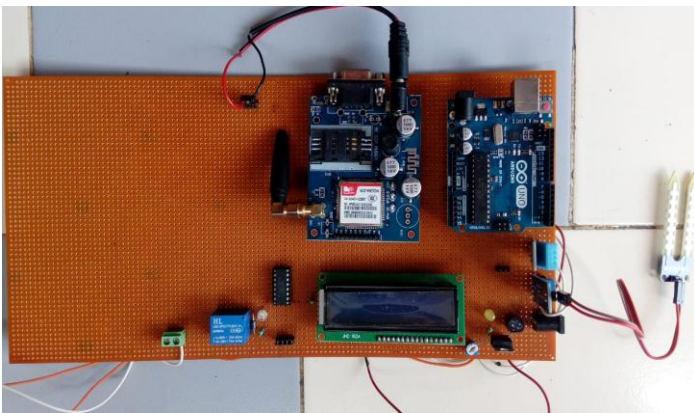
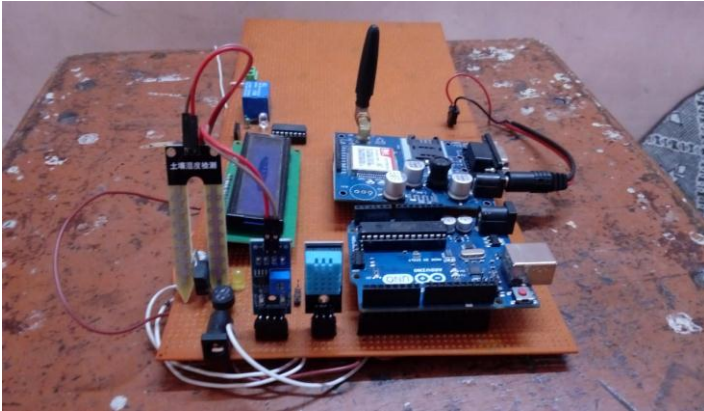
vi. HARDWARE PHOTO**vii. EQUIPMENTS USED****a) DHT11 - Humidity and Temperature Sensor:**

The DHT11 is a basic, low-cost digital temperature and humidity sensor. It uses a capacitive humidity sensor and a thermistor to measure the surrounding air, and spits out a digital signal on the data pin (no analog input pins needed). Its fairly simple to use, but requires careful timing to grab data. The only real downside of this sensor is you can only get new data from it once every 2 seconds.

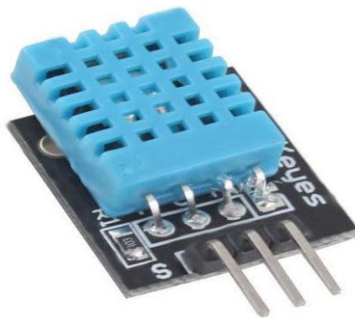
**Working principle of DHT11 Sensor:**

- DHT11 sensor consists of a capacitive humidity sensing element and a thermistor for sensing temperature. The humidity sensing capacitor has two electrodes with a moisture holding substrate as a dielectric between them. Change in the capacitance value occurs with the change in humidity levels. The IC measure, process this changed resistance values and change them into digital form.
- The measuring temperature this sensor uses a Negative Temperature coefficient thermistor, which causes a decrease in its resistance value with increase in temperature. To get larger resistance value even for the smallest change in temperature, this sensor is usually made up of semiconductor ceramics or polymers.
- The temperature range of DHT11 is from 0 to 50 degree Celsius with a +/-2 degree accuracy.
- Humidity range of this sensor is from 20 to 80% with 5% accuracy.
- The sampling rate of this sensor is 1Hz .i.e. it gives one reading for every second.
- DHT11 is small in size with operating voltage from 3 to 5 volts.

b) Soil Moisture Sensor

This sensor can be used to test the moisture of soil, when the soil is having water shortage, the module output is at high level, else the output is at low level. By using this sensor one can automatically water the flower plant, or any other plants requiring automatic watering technique. Module triple output mode, digital output is simple, analog output more accurate, serial output with exact readings.

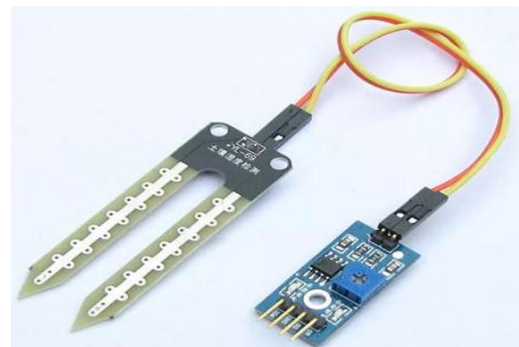

Working of Sensor:

- The soil moisture sensor consists of two probes which are used to measure the volumetric content of water.
- The two probes allow the current to pass through the soil and then it gets the resistance value to measure the moisture value.
- When there is more water, the soil will conduct more electricity which means that there will be less resistance.
- Therefore, the moisture level will be higher. Dry soil conducts electricity poorly, so when there will be less water, then the soil will conduct less electricity which means that there will be more resistance.
- Therefore, the moisture level will be lower.
- This sensor can be connected in two modes; Analog mode and digital mode.

c) **Arduino UNO R3**



The Arduino Uno is a microcontroller board based on the ATmega328. It has 14 digital input/output pins (of which 6 can be used as PWM outputs), 6 analog inputs, a 16 MHz ceramic resonator, a USB connection, a power jack, an ICSP header, and a reset button. It contains everything needed to support the microcontroller; simply connect it to a computer with a USB cable or power it with a AC-to-DC adapter or battery to get started.

The Uno differs from all preceding boards in that it does not use the FTDI USB-to-serial driver chip. Instead, it

features the Atmega16U2 (Atmega8U2 up to version R2) programmed as a USB-to-serial converter.

Revision 2 of the Uno board has a resistor pulling the 8U2 HWB line to ground, making it easier to put into DFU mode.

Revision 3 of the board has the following new features:

- 1.0 pinout: added SDA and SCL pins that are near to the AREF pin and two other new pins placed near to the RESET pin, the IOREF that allow the shields to adapt to the voltage provided from the board. In future, shields will be compatible both with the board that use the AVR, which operate with 5V and with the Arduino Due that operate with 3.3V. The second one is a not connected pin, that is reserved for future purposes.

- Stronger RESET circuit.
- Atmega 16U2 replace the 8U2.

Pin Description of Arduino Uno

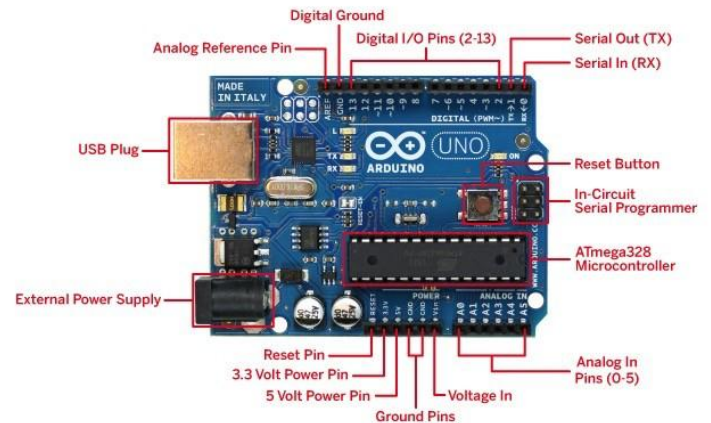

d) **Relay Driver ULN2003**

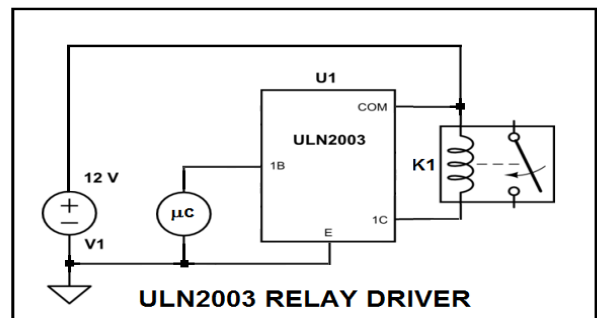

In general, while designing electronics projects the loads are controlled (switched ON or OFF) using microcontroller block. But, for this purpose the circuit requires relays, acting as controlled switches (for different circuits different types of relays are used). Depending on the signals received from the microcontroller or other control circuits the relay controls the load. The relay consists of continuous power supply and whenever it gets driven or gets control signal then the relay gets activated and loads can be turned ON or OFF. But, primarily we must know what is a relay driver circuit.

e) GSM/GPRS MODEM-SIM900

The SIM900 is a complete Quad-band GSM/GPRS solution in a SMT module which can be embedded in the customer applications. Featuring an industry-standard interface, the SIM900 delivers GSM/GPRS 850/900/1800/1900MHz performance for voice, SMS, Data, and Fax in a small form factor and with low power consumption. SIM900 can fit almost all the space requirements in your mobile application, especially for slim and compact demand of design.

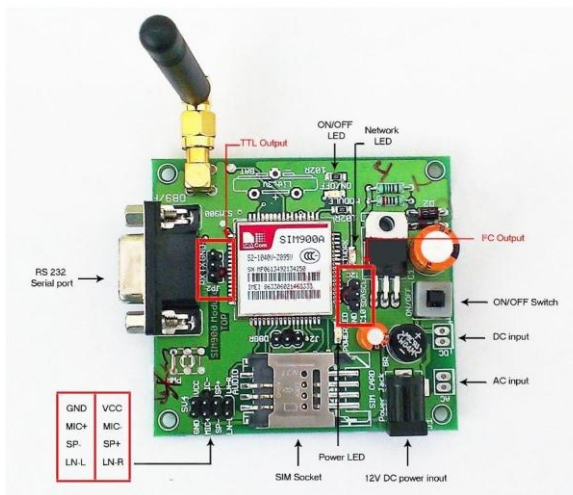

In GSM Modem we are going to use only four pins.

This four pins are as follows:

- Vcc (Power Supply)
- TxD (Transmit Data)
- RxD (Receive Data)
- GND (Ground)

viii. RESULT

The result is as expected the user gets notification about the parameters as it see changes in the parameters, the system sends the data to the website, the website shows the reading of the parameters as we open the website, through the website the control of water pump is also successful.

ix. CONCLUSION

The conclusion of this project is that the user can check on his field at any time and from anywhere in the world. The user can also connect the whole farm and control it from anywhere in the world through the website and get all the notifications through the text message sp that he can be notified even if its internet is not working.

A. Future Scope

This project can be extended in the future in many ways like making it fully automatic. So it can automatically control the pump according to the parameters. We can also add commands through which if there is no internet it can also work through text message. And at last we will try to make it for a bigger area and will try to make it fully wireless by making a wifi connected sensors so that it can cover a larger area.

B. References

1. International Journal of Trend in Research and Development, Volume 5(2): Smart Agriculture Monitoring and Security System.
2. International Journal of Advanced Research in Computer and Communication Engineering Vol. 5, Issue 3, March 2016: Agriculture Crop Monitoring using GSM.
3. International Journal of Emerging Technologies in Engineering Research (IJETER) Volume 5, Issue 3, March (2017) : Smart AGRO Using ARDUINO and GSM.