

PORTABLE BICYCLE ACCESSORIES TO REDUCE HUMAN EFFORT AND TO INCREASE RANGE AND SPEED OF BICYCLE

Darshan Bhuva¹, Sagar Bhuva²

^{1,2}Government Engineering College, Rajkot, Affiliated to Gujarat Technological University

Abstract - The invention of bicycle has had a large impact on community, both in terms of culture and of advancing modern industrial methods. Cycling is a healthy, low-affect exercise that can be performed by people of all ages, from young children to older adults. It is also amusing, low-cost and loss impact on environment. To reduce human effort for a riding bicycle uses an electric motor for purpose of moving. On this bicycle, people do not have to use their muscular power to move. It uses electric energy for motion. It is also known as e-bikes. Electric bicycle is driven by the friction driving along wheel and pulley. As per design of portable kit, that have a rechargeable battery. This makes it easy to power the bicycle whenever you want. We can use stored electrical energy as main form of energy. This electrical energy is converted into mechanical energy by motor pulley assembly and transferred to the rear wheel of bicycle. The parameters of the battery are vary according to the voltage and capacity required for the bicycle. The design of portable kit is very important. This bicycles are more powerful, fast and convenient than regular once.

Key words: Portable Electric kit, Electrical Bicycle (E-bike), Human effort, CAD, Motor, Battery, Motor Controller, Speed sensor.

1. INTRODUCTION

E-bikes are the electrical motor-powered version of motorized bicycle, which are in use since the late 19th century. The portable accessories are used for electrical bicycle to scale back human effort and also to form more convenient kit for users. An electrical bicycle is additionally referred to as e-bike. It's a bicycle with an integrated motor which is employed for propulsion. Main problem during this kit size and weight of all components. It's very difficult to suit of these components in compact size box. Second problem is that the minimum voltage of the battery. During this kit, motor is extremely depended on voltage of battery and it's very difficult to realize exact voltage from battery due to the fluctuation of load on bicycle. Third problem is that the diameter pulley because it's utilized in the varied forms of bicycle tires. In spite of everything this type of problems on portable kit we have got small motor to help rider's pedal to create somewhat more powerful e-bikes which tends closer to moped-style by means of function. However, to retain the power of bicycle, which is pedaled by the rider, by meaning it's not electric motorcycle. The portable kit for bicycle is employed to form better-off to hold and it will be attached moreover as removed easily by the user of bicycle.

1.1 Aims & Objectives

To scale back effort in pedaling of the bicycle and to enforce the comfort of consumers. This Project promotes the clean and energy efficient vehicle. Purpose of e-bikes is to deliver goods and to move passengers among privet and public bodies like Delivery Company. E-bikes aim to vary in behavior of groups during which areas are manifested in their decision to exchange their conventionally fuelled vehicles with e-bikes. We are able to enable the demonstration of measurable effects in terms of reduction of co2 emission and energy saving by inclusion of e-bikes in urban transport.

1.2 Problem Statement

Power Losses of battery due to the friction produced between outside surface of motor hub and tires and also because of friction produced in tires due to road surfaces. Second problem is that kit is losing its connect with tire on rough rod.

Following are main losses which we are concerned as follows:

- 1) Friction Losses.
- 2) Power Losses.
- 3) Energy Losses due to the fluctuation of load carrying.

- 4) Contact Losses because of the friction between motor hub surface and tires.
- 5) Battery power losses due to the speed of bicycle.

2. LITERATURE REVIEW

By the assistance of Research papers, Planning of Manufacturing Companies, Numbers of vehicles employed in now a days in all over a world, the main problems are pollution and greenhouse effect. So, now the solution on behalf of the fuelled vehicle is e-bike with no emission and to reduce human effort by portable bicycle accessories.

2.1 The German Naturalistic Cycling Study – Comparing cycling speed of riders of different e-bikes and conventional bicycles

Objective of this paper is to explore the acceleration and speed of orthodox and electrically powered bicycles under truthful status. Authors distinguished between electric bicycles which deliver provision up to 45 km/h (as called as S-pedelects) and 25 km/h (speed of pedelects). Additionally, as speed limits of 30 km/h might influence especially on the execution of speedier cyclists (e.g. Spedelect rider), the potential mean speed may be even advanced under various situations. Authors also given the variance within the user population, it is not irrational to admit that at present, e-bikes don't cause any revolution in cycling mean speed at all. The growth of e-bikes in younger cyclists is still there. It has even been embraced that the e-bicycle is going from being a "recovery vehicle" to a classy frill. By this authors gave the vision that this may change two wheeled activity and street security in the center and long stretch.

2.2 An Improved & Efficient Electric Bicycle System with the Power of Real-time Information Sharing

Firstly they're using sun based board as a hotspot for E-bicycle. Therein they utilized the 20 KW sunlight based board and it's related to the 12 v battery. So, the sun powered board is used to charge the battery. Here basic concept is that they applied solar power and it's converted into electric energy by using photovoltaic effect. They connected the solar panels within the series and it creates the extra voltage, which is used to charge battery.

The second source of energy is that they're convert the mechanical energy into electrical energy by using dynamo. Dynamo is an electrical device which generate the power with the assistance of commutator. In this paper they mentioned the procedure of how mechanical energy is converted into electrical energy and it will utilized to run the electrical bike. They connect the dynamo in the front wheel of E-bike. As the wheel of bike is rotate along the wheel commutator is also rotate and it will generate the power. Therefore the mechanical energy is converted into electrical energy and it will store in dynamo. Whenever it will be required, it will supply energy to E-bike. The diagram of their design requirements is shown in fig.

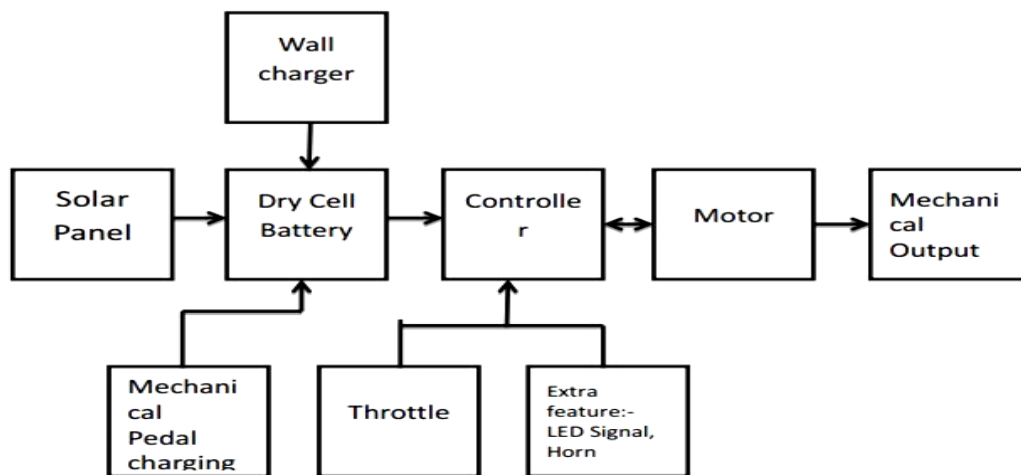

Fig -1: Process of Electric Bicycle

2.3 Electric Bike Outfitters Front Range 2.0 Kit Review

A durable, high-powered, gearless hub motor electric bike kit, custom-spoked into a wide range of rim sizes 20" to 28" and multiple hub spacing's, you choose black or silver accents. The stock display provides abundant choices for setting the top speed, pedal assist sensitivity. A flexible geared hub motor e-bike kit with rear rack-mounted battery pack, integrated tail light keeps you visible and may be used even if the motor is display is turned off. Many options in different colored hub motors, rims, and racks, front or rear mount design. A powerful internally geared hub motor that is well-suited to cargo bikes and climbing applications. It weighs more and produces more noise but offers more torque Comes with motor-inhibiting mechanical brake levers, an eight magnet cadence sensor, and a fancy LCD display with integrated USB charging port. This kit is often setup as Class 1, 2, 3, or off-road. You can adjust the top speed and determine how quickly the cadence sensor responds, choose from half-grip, full-grip, or trigger throttle.



Fig -2: ebo 2.0

3. PLAN OF WORK

3.1 Tools Required

1. **Cad of modeling**
 - NX 9.0
 - Auto Cad
 - Solid works
2. **Machining Operation**
 - Bending
 - Drilling
 - Cutting
 - Grinding
 - Welding
3. **Paint**
 - Spray paint
4. **Measurement tools**
 - Measurement tap
 - Voltmeter
 - Ammeter
 - Vernier calipers
 - Steel rule

4. ELEMENTS AND CONSTRUCTION

4.1 Motors: -

As now Kit requires one motors in vehicle. DC Motor is electrically driven which drives the pulley through belt. The motor is operated by the power of 48V battery. Now a days we have plenty of Vehicle which already give Electric drive to bikes, and a few of that’s mentioned below....

- Revolt RV 400 AI motorcycle
- Ather 450
- Hero Electric Nyx E5
- Okinawa i-Praise
- Tronx One

4.1.1 Specification

Table -1: specification of motor

Rated Voltage	48 V
Rated Power	>350 W
Design	Brushless, gearless DC motor
Wattage	350 W
Maximum speed	25-32 km/h
Weight	3.9 kg
Operation temperature	Maximum 120
Colour	Black, Silver
Maximum efficiency	Min 85%
Maximum RPM	350 RPM
Freewheel	Yes
Type	BLDC PAS sensor
Position	Rear
Ampere	0.42A



Fig -3: DC electric motor

4.2 Battery

Kit required a 48 volt lithium-ion battery, which contains 39 cells. It is very convenient to recharge the battery and it’s portable too. At the time of change or recharge we are able to take it out easily from the portable kit of the e-bike.

4.2.1 Features of our battery pack

- Compact size and simple design
- Flexible and variant dimensions
- Specially designed cabinet for various battery packs
- Different types of connectors for variant connectors
- Light weight
- Highly advanced integrated battery management system
- Advanced thermal management system
- Certification like ISO.

4.2.2 Specification

Table -2: specification of battery pack

Rated voltage	48 V
Corn. Protocol	UART
BMS	Smart BMS
Voltage scope	44-51 V
Charge mode	CC-CV(3 pin pro-movec charger)
Operation temperature	0-45
Charging light	Yes
Weight	2.8 kg
Position	Carrier
Controller position	Centre
Capacity	8.8 Ah
Material	Lithium-ion
Application	E-bike, laptop
Energy	316 Wh
Warranty	1 years
Cycle running	1000 cycle



Fig -4: Battery pack

4.3 Motor controller

The motor controller is used for saving the power of the battery by controlling the motor power which is transmitted to pulley and wheel. Motor controller takes signal from the pedal assist sensor and cut off or carry on the power supply which is depended upon the load on the motor to rotate tires of e-bike.

4.3.1 Specification

Table -3: specification of motor controller

Voltage	48 V
Power rating	350 w
Light output	Yes
Brake cut-off support	Yes
Bb pedal sensor type	Speed
Display protocol	V1
Speed limit	36 km/h
Walk assist	Yes
Battery communication	Yes
Battery connection	Integrated
Light cable	3 pin circular



Fig -4: Motor controller

4.4 Speed sensor or pedal assist sensor

The pedal assist sensor is specifically used to measure the speed of the e-bike at any time of running duration. It gives a signal to motor controller, here in project a sensor is used to measure speed to control the speed of motor.

4.4.1 Specification

Table -4: specification of speed sensor

Pluses per rpm	12 pcs
Plug type	IPX4

Wire length	Optional
Assembly position	Left



Fig -5: Speed sensor

4.5 Charger

Charger is selected on the basis of required power and ampere of battery.

4.5.1 Specification

Table -5: specification of charger

Voltage	36/48 V
Charging	2 A
Plug type	Pin



Fig -6: Charger

5. WORK FLOW OF THE PORTABLE E-BIKE KIT

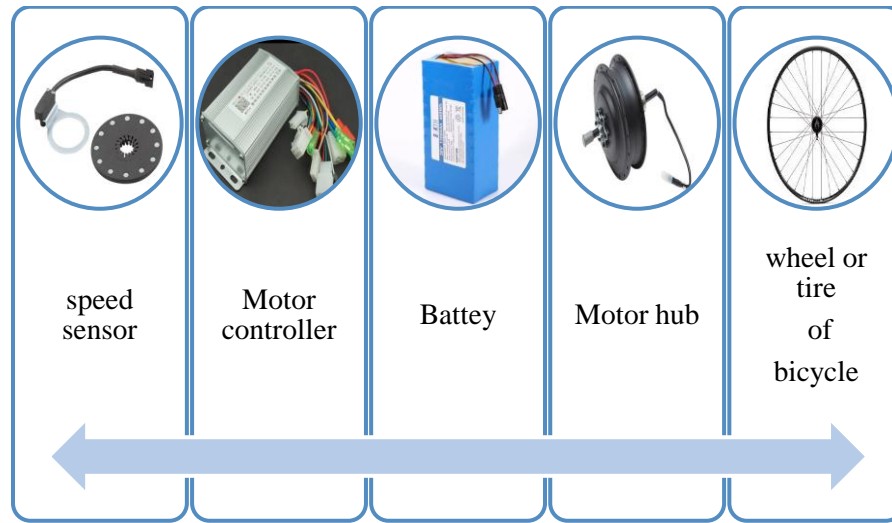

Fig -7: Working diagram of the portable kit

5.1 Operations of all components

5.1.1 Speed sensor or peddle assist sensor

Pedal Assist is an operating mode on e-bikes designed to start the e-bike motor to assist you in pedalling. Most e-bikes have inbuilt pedal-assist feature that lets you to activate the motor by pedalling rather than employing a twist or thumb throttle. The advantage is simple, rather than twisting or pressing a throttle to activate your e-bike motor, just start pedalling and also the motor will power up automatically.

Pedal Assist sensor is employed to sense that you're pedalling at the time of operation, by using one in every of (or a combination of) two types of sensors – a speed sensor or a torque sensor. The e-bike manufacturer installs the speed sensor, like the torque sensor, within the bottom bracket of the bike – the axle or shaft that connects the two pedals and allows them to rotate; the sensor may also be found inside the motor for “mid-drive” e-bikes. The speed sensor detects some forward pedal rotation or a certain rotational speed and activates the motor to power your ride. A setting on the e-bike display determines what quantity of power the motor uses to help in pedalling. The torque sensor detects the force of your pedalling before motor activation. Again, a setting on the e-bike display determines what proportion of power motor will use to help you. Lots of pedal force, like when you're pedalling up a hill, will produce more motor power than a touch force like when you're pedalling downhill.

5.1.2 Motor controller

The speed controller of an electrical bike is an electronic circuit that not only controls the speed of an electrical motor but also is a dynamic brake. This controller unit uses power from the battery pack and drives it to the hub motor. Different types of controllers are used for brushed and brushless motors. For adaptive e-bikes, a conversion kit is employed and therefore the controller is that the main component of that kit.

The electrical bike speed controller sends signals to the bike's motor hub in various voltages. These signals detect the direction of a rotor relative to the starter coil. The right function of a speed control depends on the utilization of varied mechanisms. In an exceedingly purpose-built electric bike, Hall Effect sensors help to detect the orientation of the rotor. If your speed controller doesn't include such sensors and the speed controller on an adaptive bike might not. The emf of the undriven coil is calculated to urge the rotor orientation.

5.1.3 Battery

Mounting your battery pack to your e-bike will be a challenge, there are ideal locations and there are convenient ones, rarely do they are available together as unit. Depending on your bike of choice and riding style, inside the frame and between the wheels is good for the simplest possible weight distribution and ride comfort... while on a rear rack or saddle bags is simple and convenient but can have an adverse effect on handling.

Battery packs in aluminum cases and mounting brackets make the task of mounting to your e-bike much easier while also protecting the pack from impacts, but it adds cost, weight and bulk.

Table -6: Watt hour and running capacity

Battery energy Watt hour	Load	Run time
500 wh	250 w	3 hours
500 wh	500 w	1.30 hours
500 wh	1000 w	45 minutes

Table -7: Range of running capacity

Lithium ion battery weight (lbs.)	Range (km)
6-8 lbs.	36 km

5.1.4 Motor hub

The two most typical types of hub motors utilized in electrical bicycles are brushed and brushless. The 48 volt 350 watt motor is largely used in portable bicycle kit to supply power to pulley which is mounted in last of the kit and attached to the wheel of bicycle. The power of motor output is depends on the load carrying capacity and variation on the speed of bicycle. The motor and pulley of kit joined by the timing belt, so power or motion transfer from motor to pulley is by belt driven.

The various capacity of motor is depends on the load carrying capacity of e-bike. The brushless motor is also used to convert the power of battery to in motion. After the longtime of running of motor in portable kit you have to only change the motor and easy then rigidly attached to wheel hub.

By motor controller varying power transfer to pulley is controlled. It applies to brake motor and clutch effect to motor. So, motor is main parts in portable e-bike kit which fitted next to the battery to transfer motion to pulley easily and run the wheel of the bicycle. So, the various type of operations are made by the motor in e-bike which depends on the use of the different situation because of the various design of e-bike changes the fitting place of motor.

6. TESTING PROCEDURE

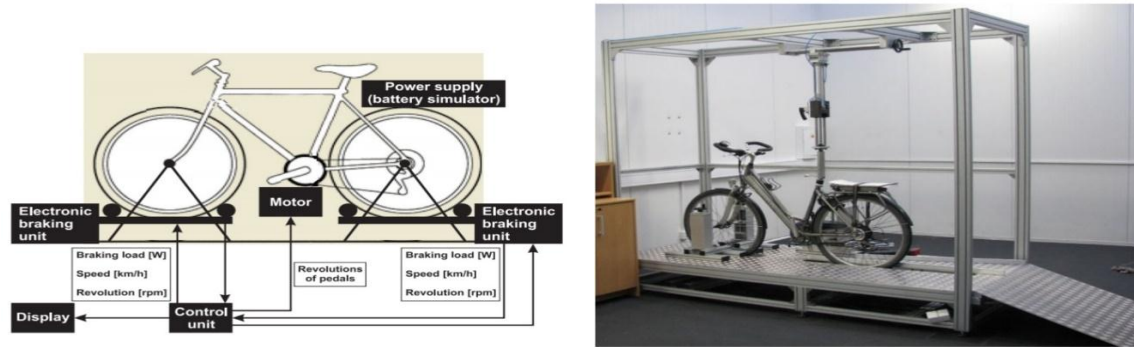

Fig -8: Experimental setup of testing procedure

6.1 Construction

6.1.1 Hardware construction

E-bike testing station is built as modular system. Flexibility is one of the important properties. Hardware chassis is assembled from metal profiles and serves as stand. The tested E-bike is fixed into this stand.

Main module cares for timing, measuring and data collecting from electronic brakes and measuring modules. The electronic brakes are connected wireless via Nordic chip. Moreover, measuring modules are often connected to testing station. During this case one measuring module is connected. Another measuring module is possible to link E-bike motor and to scale its power. Functionality, this is not suitable for testing station, because it has to open the E-bike chassis and to connect measuring module between E- bike motor and E-bike control unit. The E-bike motor and pedal motor need low voltage to control. Two power sources MANSION are available in E-bike testing station. This power sources are often controlled by the main module. The pedal motor revolution is controlled that way.

6.1.2 Electric construction

The E-bike testing station is used as measuring station for design and developing. The heart of the E- bike testing station is main control unit designed on Freescale Kinetics K60 processor tower system is employed. The electronic is planned as elevator to Freescale tower system. It is not required to take care of processor, because we are using tower development kit. The main control unit is powered by 12 V power source and it also provides power source to CAN bus. Two another power sources are used.

The E-bike control unit is additionally connected to Main Control unit. This feature allows to check motors separately. It also allows to manage support and it allows to measure motor in entire range of use automatically. The main control unit is capable to connect with electronic brake. The E-bike testing stand includes two electronic brakes. The primary brake will be connected to the front E-bike wheel and also the second brake will be connected to the rear E-bike wheel. The communication line is wireless.

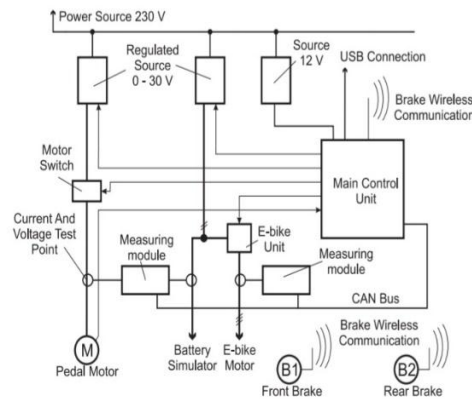

Fig -9: Construction of electrical module

6.1.3 Module construction

To calculate AC power is vital to detect period. The measuring module is able to detect periods from each voltage and current channel. To produce better functionality, the calibration is mandatory. The calibration must be done directly in measuring module, because it calculates power in each step and then sum for one period. The power calculation shows equation (1).

$$P = \frac{1}{N} \sum_{x=0}^N u_x \cdot i_x$$

N number of samples during one period
 u_x instantaneous voltage
 i_x instantaneous current

$$P = \frac{1}{N} \sum_{x=0}^N (K_u u_x + Q_u) \cdot (K_i i_x + Q_i)$$

where K_u , Q_u , K_i , Q_i are calibration constants.

Likely the computation capacity should be height. The direct memory access is used to decrease of computation power. One hundred samples are measured and then are processed. The processor should process 100 values in one millisecond. It should calibrate voltage and power, then calculate power, detect period, all for three phases and finally it should calculate total voltage, total current, total power and send it to the CAN bus. One value should be processed in less than 1.5 μ s. It is clear, the computation power is high. The processor load reach up to 98 % during measurement. To summarize the measuring module parameters:

- Calculate three current phases -40 A to 40 A 100 kSPS each
- Calculate three voltage phases -40 V to 40 V 100 kSPS each
- Calculate total 3 phase power
- Calibrate each sample (linear approximation is used)
- Provide DC measurement
- Supply AC measurement, trigger on each channel, up to 125 Hz
- Fully isolated current channels

- Voltage channels with common ground

6.2 Reading Procedure

The four basic tests are presented in this article.

- 1) Support test
- 2) Quick stop test
- 3) Reverse pedals spinning test
- 4) Load test

The first test checks the whole E-bike functionality. The pedal motor starts spinning and the support should start. The second test is quick stop test. The support should switch off in very short time maximum 280 ms after the pedal motor stop. After that test the pedal motor starts spinning in inverse direction. During this test the support should not start. The last test measures E-bikes total performance.

7. CAD MODEL

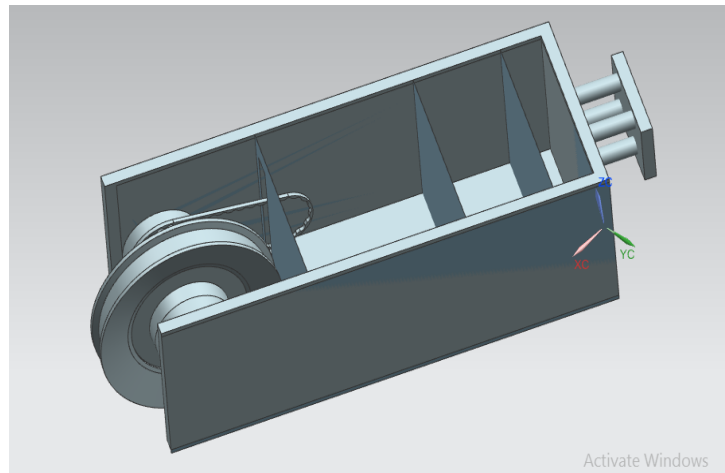

Fig -10: Assembly of motor and battery compartment

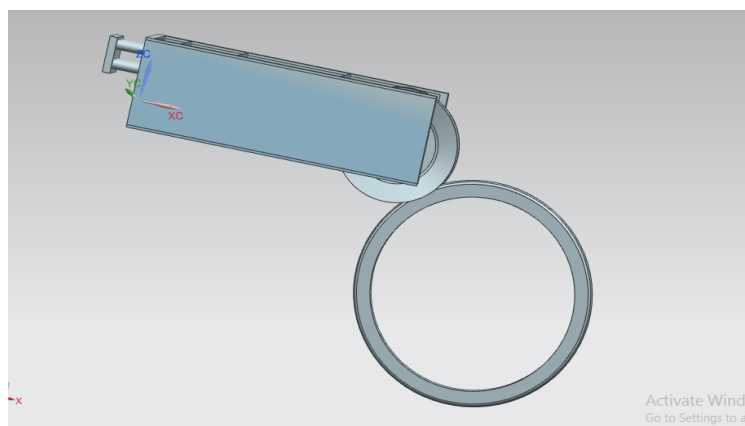

Fig -11: Assembly of portable kit and wheel

8. RESULTS

	3 battery module	2 battery module	1 battery module
Speed	48 km/h	36 km/h	25 km/h
Power	350 w	250 w	250 w
Range	48 km	32 km	16 km
Charge time	2.5 h	1.5 h	45 min
Weight	4.0 kg	3.4 kg	2.8 kg

9. CONCLUSION

By the utilization of this portable kit we will convert regular bicycle into electric bicycle (E-bike). E-bikes are zero-emission vehicles, as they emit no combustion by-products. E-bikes also provide a source of exercise for people who have trouble in exercise for an extended time (due to injury or excessive weight) because the bike can allow the rider to require short breaks from pedaling and also provide confidence to the rider that they will be able to complete the chosen path without becoming too fatigued or without having forced their knee joints too hard (people who have to use their knee joints without wearing them out unnecessarily may in some electric bikes adjust the level of motor assistance consistent with the terrain). A University of Tennessee study provides evidence that energy expenditure (EE) and oxygen consumption (VO₂) for e-bikes are 24% below that for conventional bicycles, and 64% lower than for walking. Further, the study notes that the difference between e-bikes and bicycles are most pronounced on the uphill segments. Because the number of e-bikes are increased and more powerful motors are used, capable of reaching up to 30 miles per hour (48 km/h). The cost effective portable kit is modeled for the common use of local public who can use this kit for the exercise, to save lots of time and to reach at work destination.

REFERENCES

- 1) "Electric Bikes Now Constitute 10 Percent of German Market". EVworld.com. Archived from the original on 10 September 2013. Retrieved 3 April 2013.
- 2) <https://www.indiamart.com/proddetail/60-8v-43-4ah-lifepo4-battery-pack-20511065162.html>
- 3) Kathy Chu (2010-02-12). "Electric bikes face long road in U.S."USA Today. Retrieved 2010-05-31.
- 4) "Power assisted bicycles". VicRoads website. VicRoads. Archived from the original on 28 March 2013. Retrieved 25 August 2013.
- 5) <https://www.kickstarter.com/projects/1732543648/make-your-bike-electric-the-new-rubbee-x>
- 6) <https://www.rubbee.co.uk/>
- 7) <https://auto.ndtv.com/news/revolt-rv-400-electric-motorcycle-launch-date-revealed-2072205>
- 8) <https://www.amazon.com/Olyeem-Bicycle-Motorcycle-Portable-Multifunctional/dp/B074J4P87B>
- 9) https://promovec.com/?gclid=CjwKCAjwlovtBRBrEiwAG3XJ-0vPboJGxjQlkEqG11Z_tcRREbQBPKLGDJCGVO7EBTu_3BEkTyjRMRoChFYQAvD_BwE

10) <https://www.geeky-gadgets.com/rubbee-x-electric-bike-battery-16-11-2017/>

11) <https://www.creatus.lt/rubbeex>

BIOGRAPHIES



Darshan Bhuva. He is under graduate student and pursuing degree in automobile engineering under Gujarat Technological University. His interest in manufacturing technology and design.



Sagar Bhuva. He is under graduate student and pursuing degree in automobile engineering under Gujarat Technological University. His interest in manufacturing technology and design.