

Study of Renesas Controller for the Development of PLC

Chanchal P. Jadhav ¹, Dr. Rakesh G. Shrivastava ²

¹Student, Department of Electrical Engineering, MCOERC Nashik, SPPU, Pune

²Professor, Department of Electrical Engineering, MCOERC Nashik, SPPU, Pune

Abstract - Programmable Logic Controller i.e. PLC is a special computer in the term consists various programs and capable of controlling various functions in industrial productions. Like computers, PLC contains a hardware component which includes input and output modules, central processing unit or processor, co-processor modules, power supply and peripheral devices. PLCs are demanded to work flawlessly for years in industrial environments that are hazardous to the electronic components that modern PLCs are made from. PLCs must be robust and designed for immunity to electrical noise, resistance to vibration, impact, wide range of temperature ranges and moisture. A PLC is nothing but the hard real-time system. Output must be produced in response to the input conditions provided within a limited time. In this way, related equipment can implement various production tasks based on program design and instructions. In this paper, the study of hardware and software used for the development of PLC using Renesas controller is discussed.

Key Words: Programmable logic controller, Renesas controller, Low cost, Low power consumption.

1. INTRODUCTION

Automation is the key to innovation and has been hypothetically understood as a way to increase efficiency and to improve productivity. The process of machine following predefined sequence of operation with less or no human labor, using special equipment and control devices that perform and control manufacturing processes is known as automation. The benefit of automation includes labor savings, savings in electricity costs, savings in material costs, and improvements to quality, accuracy, and precision. In the past, automation is done through relays and contactor logics. Since the human interference was more, the scope of errors was also more. But with the invention of microprocessors & microcontrollers several new tools as PLCs (Programmable Logic controllers) came in to use. These have reduced human interference, which in turn has increased correctness, accuracy, precision and efficiency.^[1] For example, PLC (Programmable Logic controller) can be used to automate the industrial fixture, to reduce the complexity of the

process. A PLC based control system can be used to simulate the automation of an industrial fixture and analyzed it for safety.^[2]

PLC's technical features when effectively combined with information technology are the key to promote the rapid development of electrical engineering automation. In current stage, electrical equipment has higher demand for calculation speed and information storage. The effective application of PLC technology can satisfy the operation demand of modern electrical engineering automation because R&D and application of PLC technology is closely related with people's life and industrial production so that it has strong practicability.^[3] PLCs are demanded to work perfectly for years in industrial environments that are hazardous to the electronic components that modern PLCs are made from. ^[4] The paper discusses about the manufacturing of the PLC using Renesas Controller. RL78 microcontrollers (MCUs) from Renesas Electronics are an advanced family of general-purpose and application-specific MCUs, combining true low power and high performance operation.

This paper thus discusses the development of PLC using Renesas controller which would be in low cost with higher performance operation.

1.1 PROBLEM DEFINATION

PLCs available nowadays in the market are having high initial cost, ladder logic programming which is hard to understand, high cost license software and requires more time when the failure occurs. Automation is the basic need in every industry to get efficient work within defined period of time. To have automated system, it is not always possible to buy the PLCs which are of higher cost. So, our aim is to develop the PLC using Renesas Controller which in other hand having low cost, no need of purchase the licensed software, can easily identify and fix the problem and it is based on Digital logic gates programming which is more easier than ladder logic programming. The basic aim of this

paper is to use of PLC in low power consumption with lower cost.

1.2 Renesas Controller

1.2.1 Basic block diagram of PLC with renesas controller

The basic block diagram of renesas controller RL78 is shown in figure 1.1

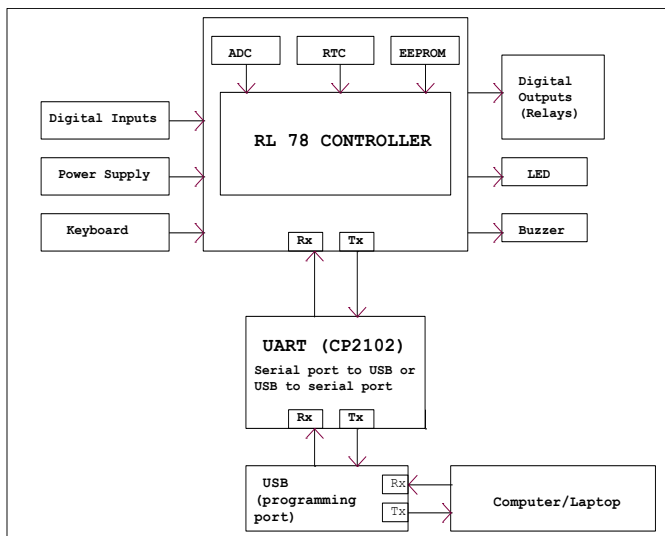

Figure 1.1 Basic Block Diagram of PLC with Renesas controller

1.2.2 Description of Block Diagram

1. Renesas RL78:

RL78 microcontrollers (MCUs) from the Renesas Electronics are an advanced family of general-purpose and application-specific MCUs, combining true low power consumption and high performance operation.

2. Relays:

A relay is a type of switch used in automation system to control various operations. The relay consists of three contacts: NO, NC and COM. The SPST relay as a way of switching: when voltage is applied to the coil of the relay the internal switch goes to the open position of the contact and disconnects the power from the load. The SPDT relay is a way of switching between 2 circuits: when there is no voltage applied to the coil one circuit "receives" current, the other one doesn't and when the coil gets energized the opposite is happening.

3. EEPROM:

EEPROM (Electrically Erasable Programmable Read-Only Memory) is in-built user-adaptable and user-modifiable read-only memory (ROM) that can be erased and reprogrammed (written to) repeatedly through the application of higher than normal electrical voltage. Unlike EPROM chips, EEPROM doesn't need to be removed from the computer to be modified.

4. Input:

Inputs are of two types: Analog and digital. Renesas is provided with digital inputs.

5. UART CP2102

A UART (Universal Asynchronous Receiver/Transmitter) is the microchip with programming for asynchronous serial communication in which the data format and transmission speeds are configurable. Specifically, the program is fed into the Renesas controller using USB via CP2102 which transmits and receives data to or from the computer.

6. LED and buzzer

LED and Buzzers are connected to the output side of the controller and specially used for indication purpose.

7. ADC

In electronics, an analog-to-digital converter (ADC, A/D, or A-to-D) is a system that converts an analog signal, such as a signal sensed by infrared sensor or light entering a digital camera, into a digital signal. This is in-built device in Renesas controller. An ADC may also provide an isolated measurement such as an electronic device that converts an input analog voltage or current to a discrete output representing the magnitude of the voltage or current.

8. RTC

A real-time clock (RTC) is a computer clock (most often in the form of an integrated circuit) that maintains the track of the current time. Although the term often refers to the devices in personal computers, servers and embedded systems, RTCs are present in almost any electronic device which needs to keep accurate time.

9. Keyboard

A keyboard as an input is a set of buttons arranged in a block or "pad" which bear digits, symbols or alphabetical

2.3 OrCAD

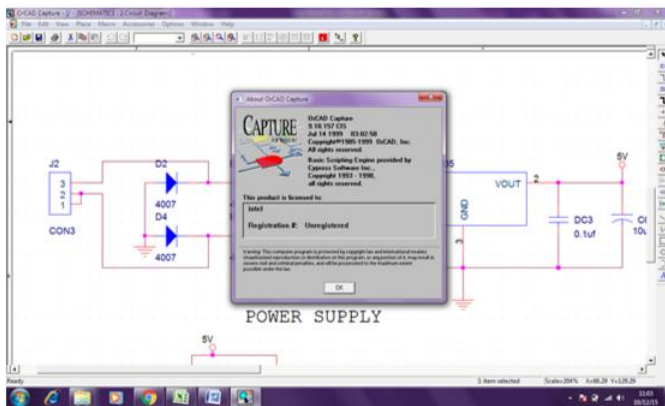

Figure 2.3 OrCAD Software opening window

OrCAD is a proprietary software tool suite used primarily for electronic design automation (EDA). The software is used mainly by electronic design engineers and electronic technicians to create electronic schematics and electronic prints for manufacturing printed circuit boards.

3. CONCLUSION

As the automation is today's need in almost all industrial and electrical applications, there is demand of PLC with reasonable cost also it must be user friendly, programming easy to understand and should have less maintenance. Thus, in this paper, we discussed about the hardware and software required for the development of PLC.

REFERENCES

- [1] Gavali Amit Bhimrao, Patil Mahadev S., "PLC Based Industrial Automation System", International Conference on Recent Trends In Engineering And Management Science - RTEM ISBN: 978-3-642-24819-9, April 2014.
- [2] Abhishek Gaikwad, Saurabh Shind, Prof. S .P. Jagtap, "PLC Based Control System Applied To Industrial Automated Fixture with Category 4 Safety", OSR Journal of Electrical and Electronics Engineering (IOSR-JEEE) e-ISSN: 2278-1676,p-ISSN: 2320-3331, Volume 9, Issue 1 Ver. IV (Feb. 2014).
- [3] Luxian Fang, "Application of PLC Technology in electrical engineering and automation control", Advances in Engineering Research (AER), volume 107 2nd International Conference on Materials Engineering and Information Technology Applications (MEITA 2016)

- [4] Yogesh R. Shelake , Devashish A. Kapadnis, Ajay R. Maile, Prof. N.M.Pawar, "PLC USING RENESAS CONTROLLER", International Research Journal of Engineering and Technology (IRJET) e-ISSN: 2395-0056 Volume: 06 Issue: 04 | Apr 2019 www.irjet.net p-ISSN: 2395-0072