

# DESIGN AND FABRICATION OF MULTIPURPOSE AGRICULTURAL MACHINE

Nair Ashwin.A<sup>1</sup>, Nair Gokul.G<sup>2</sup>, Nair Sudheeshkumar.S<sup>3</sup>, Nishad Vishal.H<sup>4</sup>

Vaishali S. Kumbhar<sup>5</sup>

<sup>1234</sup>B.E Mechanical Engineering Student, Pillai College of Engineering, New Panvel

<sup>5</sup>Professor, Dept. of Mechanical Engineering, Pillai college of Engineering, New Panvel, Maharashtra, India

\*\*\*

**Abstract** - The conditions of most agricultural labourers in India are far from satisfactory. This pushes the wage rates below the subsistence levels. The method of cultivation in most areas of India are still primitive. Most farmers continue to use native plough and other accessories. However, the problem is not one of shortage of modern machinery. The real problem is that the units of cultivation are too small to permit the use of such machinery and the existing machineries are bulkier. So, we are thinking that human and animal efforts can be replaced by some advance mechanization which will be suitable for small scale farmer from economical and effort point of view. So we are developing this equipment which will satisfy all this needs by being less bulky and to solve labour problem. In this equipment, we used a 98 cc bike engine for tilling and weeding operation and a 12V battery for seeding operation. Next two operations are manual base which is ploughing and levelling. This machine perform five farming operation (ploughing, tilling, weeding, seeding, levelling) which is used in small scale farming. By using above attachments in a modular way one may perform various farming operations in less time and economical.

**Key Words:** Ploughing, Levelling, Weeding, Seeding,

Tilling, Modular, Multipurpose.

## 1. INTRODUCTION

Agriculture has been the backbone of the Indian economy and it will continue to remain so for a long time. Agricultural sector is changing the socio-economic environment of the population due to liberalization and globalization. About 75% people are living in the rural area and are still dependent on agriculture. About 43% of geographical area is used for agricultural activity. Agriculture has been the backbone of the Indian economy. As Indian population is growing continuously, the demand for producing crop per hector is also increasing, this requires efficient and high-capacity machines. So mechanization in agricultural industry plays an important role in Indian economy. These tools are used in ploughing, levelling, tilling, for sowing of

seeds and weeding. Modern agricultural techniques and equipment's are not used by small land holders because these equipment's are too expensive, bulky and difficult to acquire. By adopting scientific farming methods maximum yield and good quality crops which can save a farmer from going bankrupt but majority of farmers still uses primitive method of farming techniques due to lack of knowledge or lack of investment for utilizing modern equipment. The use of hand tools for land cultivation is still predominant in India because tractors require resources that many Indian farmers do not have easy access too. The need for agricultural mechanization in India must therefore be assessed with a deeper understanding of the small holder farmer's activities. The seed feeding and crop cutting are the important stages in the agriculture field. The design of multipurpose agriculture equipment machine will help Indian farmers in rural side and small farm. It will reduce the cost of weight of the machine, seed feeding and crop cutting the field and will help to increase economic standard of an Indian farmer.

### 1.1 Major Challenges Faced By Small-Medium Scale Farmers

1. Traditional methods for production as traditional technology is the main cause of low production because it takes more time and more manpower is needed.
2. The Modern agricultural techniques and equipment's are not used by small land holders because these equipment's are too expensive, bulky and difficult to acquire.
3. High cost of Farm Inputs as over the years rates of farm inputs have increased. Farm inputs include fertilizer, insecticide, pesticides, farm labour cost etc.
4. Impact of Globalization: This is due to the rising input costs and falling output prices. This reflects the combination of reduced subsidy and protection to farmers.

5. Providing Food Security as before the introduction of green revolution in India, the food grain production were not self sufficient in terms of production.

## 2. LITERATURE REVIEW

The following chapter discusses the literature survey done in Multipurpose Agricultural Machine. The chapter further describes history, background and different types of Multipurpose Agricultural Machines,

Mr.Sheikh Mohd Shahid Mohd Sadik and Mr.H.A.Hussain published a paper on multipurpose farming machine which has a considerable potential to greatly increase productivity of crops.[1]

Mr.Humbade A.B., Mr.Kalingwar C.M., Mr.Kadam. N.S.,Davargave,Mr.M.M.,Prof. Lande.S.B published a paper on,this Project represents work on multipurpose vehicle for farm, which can easily use for digging, seeding, spreading, fertilizer.[2]

Mr. Nitin kumar Mishra, Mr.Shashwat Khare,Sumit, Mr.Singh, Mithun Dabur published a paper on this,project which represents the top concentration of our design is the cost and operational ease in case of small farm units.[3]

Prof.S.N.WAGHMARE, Rashmi S.Chimote, developed the Concept to design a project for small scale farmers. Paper number-IRJET V319177 [4]

## 3. METHODOLOGY

This is the following functions of Multipurpose Agricultural Machine,

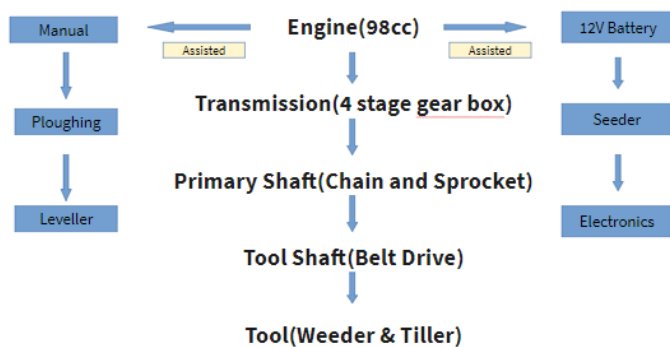

Fig 1: Flowchart of the Functions of Machine

For the process of Multipurpose Agricultural machine, The frame is made up of mild steel which gives the desired strength. It includes all the equipments together in a modular way i.e 98 cc engine, seeder tool and rest of the tools depending upon the functions. There is a handle placed at the end part of the machine where the engine is mounted, so manpower will be required to push the

machine forward for the land preparation process but effort required will be less as there will be assistance from the engine power. Now starting from the process of weeding,

A primary shaft is placed in the front side of the machine supported with a pillow bearing where it gets driven by a 98 cc bike engine through a chain drive whereas the tool shaft gets driven by the primary shaft through a belt drive. As the weeding process is done for the removal of unwanted plants in the field crops. After the weeding process, the next three process i.e tilling, ploughing and seeding will be functioning simultaneously. So now the weeder tool can be replaced by a tiller tool to mix organic matter into soil, help eliminate weeds, break up crusted soil, or loosen up a small area for planting. For the next process, the plough tool is attached using fasteners to the both sides of the frame parallel to the tilling tool. It will function the process of breaking or loosening the soil before sowing seed and turning it over for uprooting weeds and aerating the soil which will require manpower but the effort required will be less because of the power assistance from the engine to the tool shaft. The seeder tool is also placed at the side of the engine, as the tool is gaining power from a 12V battery. The tool basically performs sowing which is the process of introducing seeds into the soil simultaneously after ploughing is done. By this mechanism it offers greater precision as the seed is sown evenly and at the desired rate. After the process of digging by using plough tool and seeding, the final step of covering the soil is to be done by the use of this leveller. The leveller tool is also attached at the same place where plough tool was attached at both sides of the frame. As levelling is also done manually, it helps in the uniform distribution of water in the fields during irrigation. After completion of all the process, all these parts can be connected in such a way that in every stage of agriculture the equipment can be rearranged or easily assembled with fasteners to required specifications of field operation in a modular way, so this makes the machine less bulky and more efficient.

## 4. CONSTRUCTION

In this project, the design and analysis of main frame is shown as Frame Dimensions:

Length: 500 mm

Width: 250 mm

Height: 400 mm

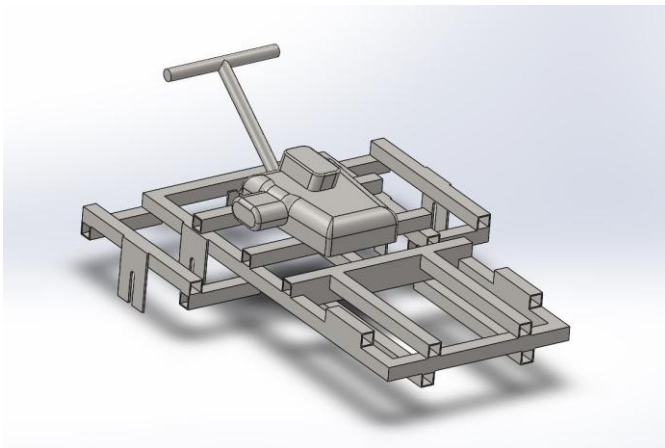

**Fig 2: Frame Design**

The tools which used in the agriculture process are,

#### 4.1. Weeder Tool

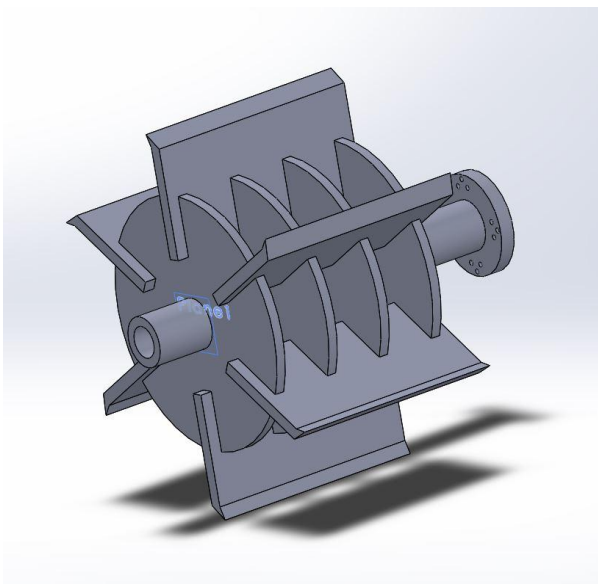

**Fig 3: Weeder Tool**

Specifications:

- Blades Diameter:-300mm
- Shaft Bore:-25mm
- Shaft Diameter:-50mm
- Tool Material:- M.S
- Shaft Length:-325mm

Weeding is the removal of unwanted plants in the field crops. The tool is placed in the tool shaft at the front of the machine and it is assisted by a 98 cc engine through a chain drive and also from primary shaft through a belt

drive. Weeding is one of the critical stages in rice cultivation and affects yield and quality of rice. As the manually operated weeder is operated between the rows of rice crop by pushing and pulling action of weeder, this power operated weeder is operated in between the crop rows in forward direction only. The weeds were cut, uprooted and thoroughly mixed in to the soil by rotary cutter blade.

#### 4.2. Tiller Tool

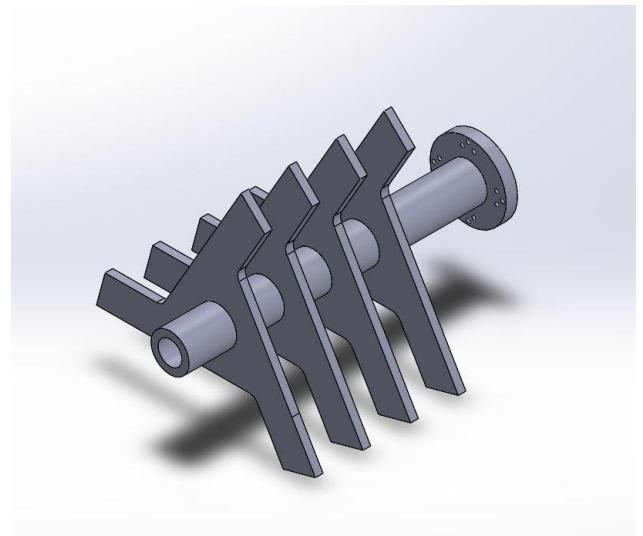

**Fig 4: Tiller Tool**

Specifications:

- Blade Diameter:-280mm
- Shaft Bore:-25mm
- Shaft Diameter:-50mm
- Tool Material:- M.S
- Shaft Length:-325mm

A Tiller tool is a agricultural equipment fitted with rotary tillers is placed in the tool shaft at the front of the machine which gives a smooth resistance to all farm activities assisted by a 98 cc engine through a chain drive and also from primary shaft through a belt drive. One of the most important functions of tiller tool is that it prepares an accurate seeded for the crop to be planted & warms the soil before planting by burying its remnant into it. By controlling weeds it helps in the proper growth of the crops. Power tiller has made possible the harvesting of every kind of crop. It not only improves soil aeration, eliminates weeds, maintains soil moisture levels, stimulate the microorganisms to become more active but also develops the provision of nutrients in the soil

### 4.3. Plough Tool

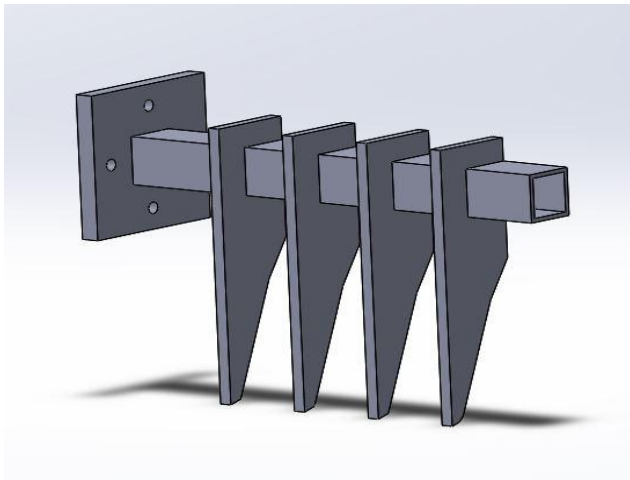

**Fig 5:** Ploughing Tool

Specifications:

Tool Depth:- 200mm

- Tool Thickness:-8mm

- Tool Material:- M.S

Ploughing is the process of breaking, loosening the soil before sowing seed and turning it over for uprooting weeds and aerating the soil. It is a manual process, as the plough tool is attached using fasteners to the both sides of the frame parallel to the tilling tool which requires manpower but the effort required will be less because of the power assistance from the engine to the tiller tool, as both the process is functioning simultaneously.

### 4.4. Seeder Mechanism

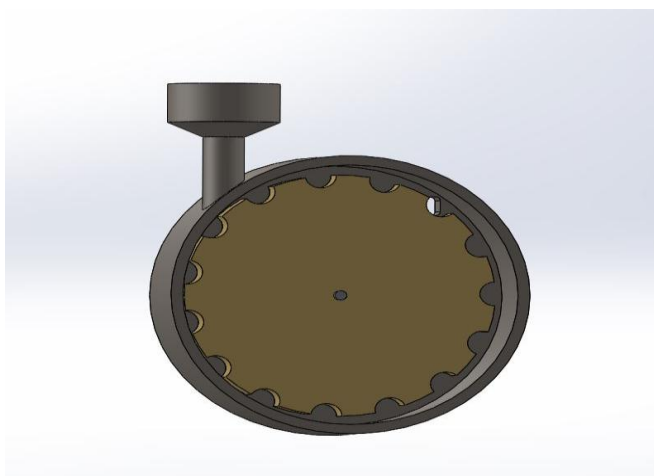

**Fig 6:** Seeder Tool

Specifications:

Seeder rpm:- 480rpm

- Seeder Casing Material:- Plastic

- Motor:- 12V DC Motor

- Battery: 12V, 5Ah Galvanic cell

- Hopper Diameter:-46mm

Seeder tool basically performs sowing which is the process of introducing seeds into the soil. In sowing, generally little soil is placed over the seeds. Seeds have to be sown at a proper depth. This tool is placed at the side of the engine and the mechanism works simultaneously with process of ploughing. The seeder tool is gaining power from a 12V battery. As by this mechanism it offers greater precision as the seed is sown evenly and at the desired rate.

### 4.5. Levelling Tool

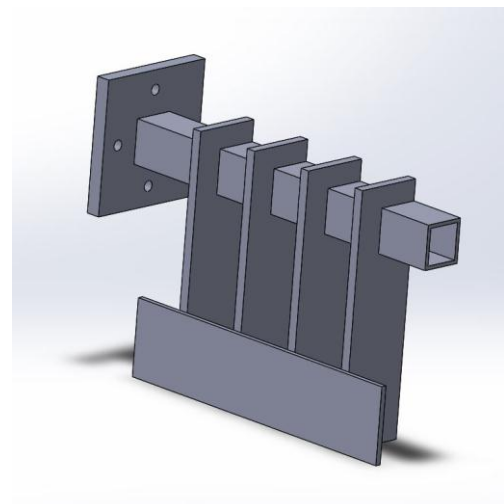

**Fig 7:** Leveller Tool

Specifications:

- Tool Thickness - 5mm

- Tool Height - 200 mm

- Tool Material - M.S

The leveller has an important role in the preparation of soil. After the process of digging by using plough tool and seeding, the final step of covering the soil is to be done by the use of this leveller. It is also a manual process, as the tool is also attached at the same place where plough tool was attached at both sides of the frame. It helps in the uniform distribution of water in the fields during irrigation. The levelling of the ploughed fields prevents

the top fertile soil from being carried away by strong winds or washed away by rain water. It also used to prevent the loss of moisture.

#### 4.6. Tool Shaft

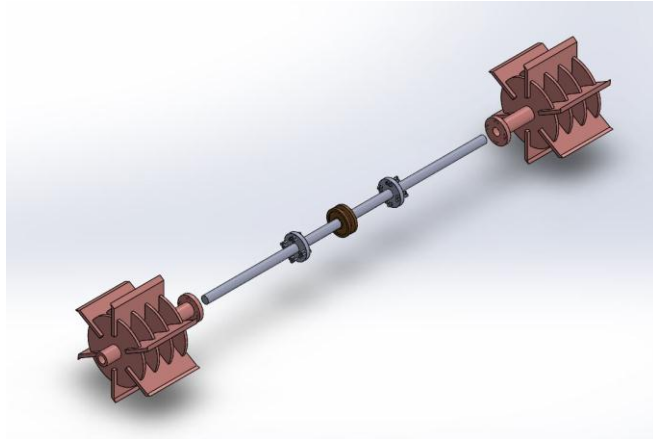

**Fig 8:** Tool Shaft Assembly

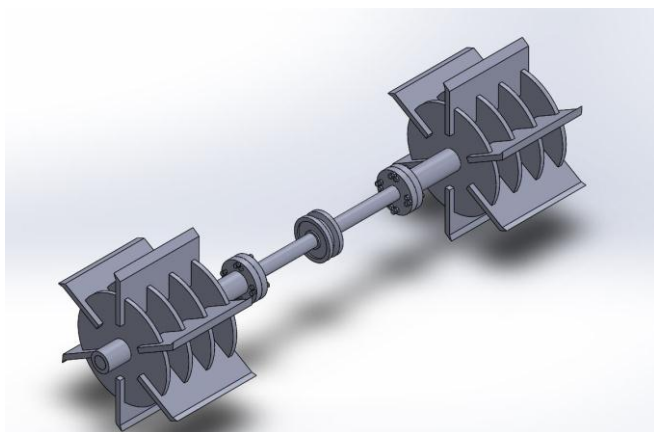
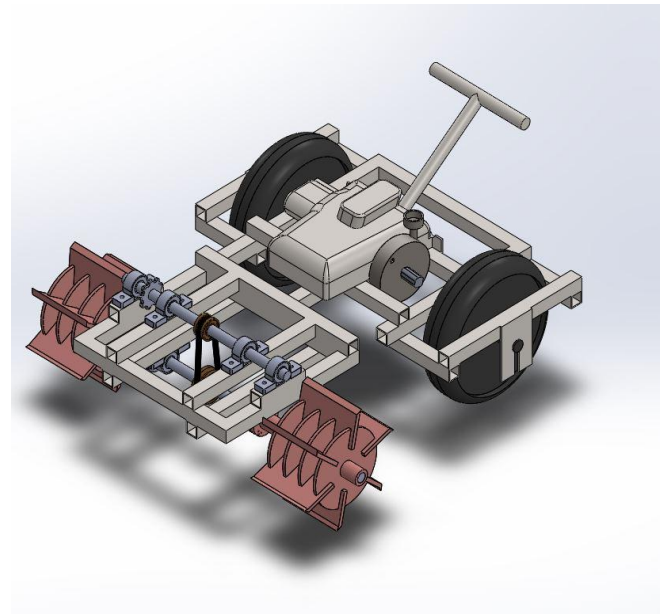

**Fig 9:** Tool Shaft

Specifications:

- Tool shaft length - 1 m
- Inner Shaft Diameter - 25 mm
- Outer Shaft Diameter - 50 mm
- Shaft Material - M.S

#### 4.7. Final Assembly



**Fig 10:** Final Assembly

### 5. DESIGN CALCULATIONS

#### 1. For Chain Drive:

$$\text{Power} = 5.97 \text{ kW}$$

Step 1:

Number of teeth on Small Sprocket = 15

Number of teeth on Large Sprocket = 43

[From Splendor Bike Specification]

Gear Ratio,  $i = Z_2/Z_1 = 2.866$  [ PSG 7.74 ]

Service Factor,

$$k_s = k_1 * k_2 * k_3 * k_4 * k_5 * k_6$$

$$k_s = 1.25 * 1 * 1 * 1 * 1 * 1$$

$$k_s = 1.25$$

Design power,  $P_d = P * k_s = 5.97 * 1.25 = 7.46 \text{ kW}$

Step 2:

Standard Pitch,

$$p = 12.7 \text{ mm}$$

[From Splendor Bike Specification]

Pitch Diameter of Smaller Sprocket,

$$d_1 = \text{Pitch} / \sin[180/Z_1] \text{ [ PSG 7.78 ]}$$

$$\mathbf{d_1 = 61mm}$$

Pitch line velocity of Smaller Sprocket;

$$V = (3.14 * d_1 * N_1) / 60 \Rightarrow \mathbf{4.79 \text{ m/s}}$$

Pitch Diameter of Large Sprocket;

$$d_2 = \text{Pitch} / \sin[180/Z_2] \text{ [ PSG 7.78 ]}$$

$$\mathbf{d_2 = 174mm}$$

Step 3:

Selection of Chains based on breaking strength;

$$N = Q * V / 102 * n * k_s \text{ [PSG 7.77 ]}$$

$$Q = N * 102 * n * k_s / V$$

As;

n = Allowable FOS

So, For  $n_1 = 1500 \text{ rpm} \Rightarrow n = 13.2$ , [ PSG 7.77 ]

$$Q = 7.46 * 102 * 13.2 * 1.25 / 4.79$$

$$\mathbf{Q = 2621.12 \text{ kgf}}$$

Chain Selection [ PSG 7.71 ]

DR40

$$A = 0.88 \text{ cm}^2$$

$$D_r = 7.95 \text{ mm}$$

$$Q = 2820 \text{ kgf}$$

$$P = 12.7 \text{ mm}$$

$$\text{Weight per metre} = 1.2 \text{ kgf}$$

Step 4:

Bearing Pressure;

$$N = \sigma * A * v / 102 * k_s \text{ [PSG 7.77 ]}$$

$$\sigma = P * 102 * k_s / A * v$$

$$= 5.97 * 102 * 1.25 / 0.88 * 4.79$$

$$\mathbf{\sigma = 180.57 \text{ kgf/cm}^2}$$

Allowable Bending Pressure [ PSG 7.77 ]

$$[\sigma_b] = 1.85 \text{ N/mm}^2, \text{ for } N_1 = 1500 \text{ rpm}$$

$$= 1.85 * 100 = \mathbf{185 \text{ kgf/cm}^2}$$

As,  $\sigma < [\sigma_b]$

Selected Chain is Safe

Step 5:

Length of Chain [ PSG 7.75 ]

$$L_p = 2a_p + [(Z_1 + Z_2) / 2] + [(Z_2 - Z_1) / 2 * 3.14]^2 / a_p$$

Approx. Centre Distance [ PSG 7.75 ]

$$a_p = a_0 / p$$

Assuming  $a_0 = 40p$

$$a_p = 40p / p = 40$$

$$L_p = 2 * 40 + [(15 + 43) / 2] + [(43 - 15) / 2 * 3.14]^2 / 40$$

$$L_p = 110 \text{ mm}$$

$$\mathbf{L = L_p * p = 1397 \text{ mm}}$$

Step 6:

Exact Centre Distance

$$a = [(e + (e^2 - 8m)^{1/2}) / 4] * p \text{ [ PSG 7.75 ]}$$

As,

$$e = L_p - (Z_1 + Z_2) / 2 \text{ [ PSG 7.75 ]}$$

$$\mathbf{e = 81}$$

$$m = [(Z_2 - Z_1) / 2 * 3.14]^2 \text{ [ PSG 7.75 ]}$$

$$= [43 - 15 / 2 * 3.14]^2$$

$$\mathbf{m = 19.85}$$

$$a = [(81 + (81^2 - 8 * 19.85)^{1/2}) / 4] * 12.7$$

$$\mathbf{a = 511.22 \text{ mm}}$$

Outside Diameter for Large Sprocket

$$D_o = [(N + 2) * p] / 3.14$$

$$\mathbf{D_o = 182 \text{ mm}}$$

Outside Diameter for Small Sprocket

$$D_o = [(N + 2) * p] / 3.14$$

$$\mathbf{D_o = 68 \text{ mm}}$$

Root Diameter for Large Sprocket

$$D_R = D - 2b$$

$$D_R = 174 - 2 * 5.05 = 164 \text{ mm}$$

Root Diameter for Small Sprocket

$$D_R = D - 2b$$

$$D_R = 61 - 2 * 5.05 = 51 \text{ mm}$$

## 2. For Shaft Diameter:

$$T = (3.14 * d^3 * \tau) / 16$$

$$\sigma_y = 300 \text{ N/mm}^2 = 300 * 10^6 \text{ N/m}^2$$

$$\tau = 0.5 * (300 * 10^6 / 3) \text{ N/m}^2$$

$$\tau = 50 * 10^6 \text{ N/m}^2$$

$$T = (3.14 * d^3 * \tau) / 16$$

$$1500 * 10^3 = (3.14 * d^3 * 50) / 16$$

$$d = 53 \text{ mm}$$

## 3. For Tool Shaft Diameter:

$$\tau = 50 \text{ MPa}$$

$$T_{\text{Engine}} = 38.07 \text{ Nm}$$

$$\text{Gear ratio} = 3.071$$

$$T_{\text{Primary Shaft}} = 38.07 * 3.071 = 116.912 \text{ Nm}$$

$$T_{\text{Tool Shaft}} = \text{Drive Ratio} * T_{\text{Primary Shaft}}$$

$$= D / d * T_{\text{Primary Shaft}}$$

$$= 1.4545 * 116.912$$

$$T_{\text{Tool Shaft}} = 170.05 \text{ Nm}$$

$$\text{Weight of tool on one side} = 17 \text{ kg} * g = 116.77 \text{ N}$$

By symmetry  $R_A = R_B$

$$R_A = R_B = 116.77 \text{ N}$$

$$\text{Therefore, } M = 54.20 \text{ Nm}$$

$$T_{\text{eq}} = \sqrt{M^2 + T^2} = 178.478 \text{ Nm}$$

$$T_{\text{eq}} = (3.14 / 16) * d^3 * \tau$$

$$d = 0.02629 \text{ Nm}$$

$$d = 26 \text{ mm}$$

## 6. CONCLUSION

Practically our multipurpose agricultural equipment can be used for tilling, ploughing, seeding, weeding and for levelling purposes. All the parts are connected in such a way that in every stage of agriculture the equipment can be rearranged or easily assembled with fasteners to required specifications of field operation in a modular way, so this makes the machine less bulkier than the rest of the multipurpose machines. The team has successfully combined many ideas from various fields of mechanical engineering and agricultural knowledge to improve the yield and by reducing the labor effort and expenses. The whole idea of a modular multipurpose equipment is a new concept and can be successfully implemented in real life situations.

## ACKNOWLEDGEMENT

We would like to express our appreciation to all those who were instrumental in completion of our report. Special gratitude to our Principal Sir Dr. Sandeep. M. Joshi, our H.O.D of the Mechanical Department, Dr. Dhanraj. P. Tambuskar and our project guide Prof. Vaishali . S. Kumbhar

## FUTURE SCOPE

By increasing the equipment strength and quality to its peak, we can have multipurpose agricultural equipment for life time usage. By providing hydraulics, gear arrangements and some minor adjustments the equipment can also be made as tractor powered equipment.

- [1] We can interface sensors to this Machine so that it can monitor some parameters.
- [2] We can add Wireless Technology to Control Machine.
- [3] We can add More Drill for different crops.
- [4] We can add water tank + fertilizer tank in Machine to reduce more efforts.
- [5] There are to be proper provisions are needed to couple the machine with the tractor.
- [6] We can add solar panel for spraying system .

## REFERENCES

### BOOKS

1. Murray J.R, Tullberg J.N and Basnet B.B (2017). Planters and their Components - School of Agronomy and Horticulture. University of Queensland, Australia.

2. Sharma D.N. and Mukesh S.(2010).Farm Machinery Design Principles and Problems.(2<sup>nd</sup> ed.). Jain brothers. New Delhi, India.



**Nishad Vishal Hariram**  
B.E. in Mechanical Engineering  
Pillai College of Engineering

#### RESEARCH PAPERS

1. Mishra N.K, Khare S, Singh S and Dabur M.(2017).MULTIPURPOSE AGRICULTURE MACHINE (2<sup>nd</sup> ed.). MadhyaPradesh, India (IRAJ)
2. Pandey MM.(n.d).INDIAN AGRICULTURE – AN INTRODUCTION. Director Central Institute of Agricultural Engineering. Bhopal, India.
3. Sheikh M.S,Hussain H.A.(2015).This multipurpose farming machine has considerable potential to greatly increase productivity of crops. Karnataka, India. ( IJSARTV )
4. Humbade A.B., Kalingwar C.M., Kadam. N.S., Davargave M.M.,Prof. Lande.S.B.(2017). “MULTIPURPOSE AGRICULTURE VEHICLE” International Journal of General Science and Engineering Research(Vol 3(2)) (IJGSER), ISSN 2455-510X, 126-129.
5. WAGHMARE S. N and Chimote R. S (2016).Concept to design a project for small scale farmers(3<sup>rd</sup> ed.). Nagpur, India. (IRJET)

#### BIOGRAPHIES



**Vaishali. S.Kumbhar**  
Professor  
Dept. of Mechanical Engineering  
Pillai College of Engineering



**Nair Ashwin Anand**  
B.E. in Mechanical Engineering  
Pillai College of Engineering



**Nair Gokul Gopalakrishnan**  
B.E. in Mechanical Engineering  
Pillai College of Engineering



**Nair Sudheeshkumar  
Sashikumar**  
B.E. in Mechanical Engineering  
Pillai College of Engineering